

This Manual is provided by
CBTricks.com

Someone who wanted to help you repair your equipment
scanned this manual.

If you would like to help us put more manuals online support us.

Supporters of CBTricks.com paid for the hosting so you would have this file.

CBTricks.com is a non-commercial personal website was created to help promote the exchange of service, modification, technically oriented information, and historical information aimed at the Citizens Band, GMRS (CB "A" Band), MURS, Amateur Radios and RF Amps.

CBTricks.com is not sponsored by or connected to any Retailer, Radio, Antenna Manufacturer or Amp Manufacturer, or affiliated with any site links shown in the links database. The use of product or company names on my web site is not endorsement of that product or company.

If your company would like to provide technical information to be featured on this site I will put up on the site as long as I can do it in a non-commercial way.

The site is supported with donation from users, friends and selling of the Galaxy Service Manual CD to cover some of the costs of having this website on the Internet instead of relying on banner ads, pop-up ads, commercial links, etc. to pay my costs. Thus I do not accept advertising banners or pop-up/pop-under advertising or other marketing/sales links or gimmicks on my website.

ALL the money from donations is used for CBTricks.com I didn't do all the work to make money (I have a day job). I all didn't do all this work for someone else to make money also, for example the ebay CD sellers.

All Trademarks, Logos, and Brand Names are the property of their respective owners.
This information is not provided by, or affiliated in any way with any radio or antenna Manufacturers.
Thank you for any support you can give.

hy-gain I, II and III
by **hy-gain**

MODELS 2681, 2682, 2683
CITIZENS TWO-WAY RADIO
mobile

Manufactured and Distributed by
Hy-Gain de Puerto Rico, Inc.
P.O. Box 68 State Hwy. 31, Km. 4.0
Naguabo, Puerto Rico 00718



First Printing, September, 1976
Original Edition, September, 1976 - PN 820105

TABLE OF CONTENTS

	page
CHAPTER 1—GENERAL INFORMATION	1
Introduction	1
Warranty Service Department	1
How to Ship Returns	1
Purchase of Parts	2
Specifications	2
CHAPTER 2—THEORY OF OPERATION	3
General	3
Phase Locked Loop Frequency Synthesizer	3
Receiver	5
Transmitter	6
Noise Blanking Circuit (2683 only)	7
TX Lamp Circuit (2683 only)	7
RX Lamp Circuit (2683 only)	7
PA Amplifier and Switch (2683 only)	7
CHAPTER 3—ALIGNMENT	9
General	9
Recommended Tools and Equipment	9
Transmitter Alignment Procedure	9
Equipment Set-up	9
Pre-Alignment Frequency Check	10
VCO Alignment	10
RF Output Adjustment	10
Transmitter Frequency Check	11
Receiver Alignment Procedure	12
Equipment Set-up	12
Receiver Alignment	12
Tight Squelch Adjustment	13
CHAPTER 4—CHARTS AND DRAWINGS	17
Voltage Measurement Charts	17
Main P.C. Board Component Outline, Model 2681	21
Main P.C. Board Component Outline, Model 2682	25
Main P.C. Board Component Outline, Model 2683	29
Front Panel Lamp Controller P.C. Board Component Outline (2683 only)	33
Meter P.C. Board Component Outline (2683 only)	37
Parts List	41
Schematic Diagrams	53

List of Illustrations

Figure		Page
2-1	Block Diagram of PLL Circuitry	4
2-2	Block Diagram, Models 2681 and 2682	foldout
2-3	Block Diagram, Model 2683	foldout
3-1	Equipment Set-up, Transmitter Alignment	10
3-2	Connection of Frequency Counter and Dummy Load	11
3-3	Equipment Set-up, Receiver Alignment	12
3-4	Components Adjusted for Transmitter Alignment	14
3-5	Components Adjusted for Receiver Alignment	15
4-1	Component Outline, Model 2681	23
4-2	Component Outline, Model 2682	27
4-3	Main P.C. Component Outline, Model 2683	31
4-4	Front Panel Lamp Controller P.C. Board Component Outline (2683 only)	35
4-5	Meter P.C. Board Component Outline (2683 only)	39
4-6	Schematic Diagram, Model 2681	foldout
4-7	Schematic Diagram, Model 2682	foldout
4-8	Schematic Diagram, Model 2683	foldout

CHAPTER 1 — GENERAL INFORMATION

Introduction

This service manual contains all the information needed to service and repair the Hy-Gain I, Hy-Gain II, and Hy-Gain III transceivers (Models 2681, 2682, and 2683). It includes an explanation of theory of operation and alignment procedures. Revision, addendum, and errata sheets will be published as needed. Insert them as required in the manual.

The H-Gain I, II, and III radios are full 23-channel transceivers designed and type accepted for Class D Citizens Radio Service, as designated by the Federal Communications Commission (FCC).

They are compact mobile units, completely solid-state, and highly reliable with low power consumption. The PLL (Phase Locked Loop) synthesizer provides immediate operation on all 23 channels. Model 2681 incorporates an automatic noise limiter (ANL), while in model 2682 the automatic noise limiter function can be selected by a switch on the front panel. In model 2683 a noise blanker circuit has been added and may be controlled by the ANL/NB switch on the front panel. Output jacks for an optional telephone-style handset are also included. Use the units with 12 VDC (nominal), either negative or positive ground.

Warranty Service Department

For help with technical problems, for parts information, and information on local and factory repair facilities, contact the National Service Manager. When you write, please include all pertinent information that may be helpful in solving your problem. Address your letter to:

Hy-Gain Warranty Service Department
4900 Superior Street
Lincoln, Nebraska 68504
Attn: National Service Manager

The Warranty Service Department can repair any unit. Before shipping the unit, contact the National Service Manager. Often a problem is field solvable with just a little extra help. This can save lost time and shipping costs. Limit factory returns to difficult problems.

How to Ship Returns

To return a unit, get a return authorization first. This is important. You will only delay the handling of your unit if you ship without it. If you must ship immediately, telephone or telex the National Service Manager for expeditious service.

When you request return authorization, you may request notification of completion of repairs. The notification will include a copy of the bill. Paying the bill before we return your unit can save the cost of a C.O.D. fee.

For warranty repair, prepare a letter in duplicate containing the following information (for out-of-warranty repair, delete items 2 and 3):

1. your name and address
2. purchaser's name and address
3. proof of purchase
4. serial number
5. a complete description of the problem
6. the return authorization

Check the unit to see that all parts and screws are in place, and attach an envelope containing a copy of the letter directly to it so the information is not overlooked. Wrap the unit and envelope in heavy paper or put them in a plastic bag. If the original carton is not available, place the unit in a strong carton at least six inches larger in all three dimensions than the unit. Fill the carton with resilient packing material (shredded paper, excelsior, bubble pack, etc.). Seal it with gummed paper tape, tie it with a strong cord, and ship it by prepaid express, United Parcel Service, or insured parcel post to the address given previously. Mail the original of the letter in a second envelope to that same address.

It is important that the shipment be well-packed and fully insured. Damage claims must be settled between you and the carrier and this can delay repair and return of the unit.

All shipments must be sent PREPAID. We **do not accept** collect shipments. After the unit has been repaired, we will send it back to you C.O.D. unless the bill is prepaid. Unclaimed or refused C.O.D. shipments will not be reshipped until payment in full is received. These items become the property of Hy-Gain 60 days after refusal or return and will be sold for payment of charges due.

Units with unauthorized field modifications cannot be accepted for repair.

Purchase of Parts

Parts can be purchased from any Hy-Gain Service Center or from the factory Warranty Service Department. When ordering, please supply the following information:

1. unit model number
2. unit serial number
3. part description
4. part number

Specifications

General

Channels all 23 channels in the Citizens Band
(26.965 MHz — 27.255 MHz)

Antenna impedance 50 ohms, nominal

Power requirements 11.5 VDC-14.5 VDC negative
or positive ground

Compliance type accepted under the FCC Rules.
Part 95

Receiver Section

Circuitry dual conversion superheterodyne with
rf amplifier stage and 455 KHz ceramic filter

Sensitivity 0.7uF for 10dB (S+N)/N ratio

Intermediate frequency 1st IF - 10.695 MHz
2nd IF - 455 KHz

Audio output 3 watts, maximum

Current drain, receive about 300 mA (no signal)

Transmitter Section

RF power output 4 watts

Emission AM, type 6A3

Spurious response rejection all harmonic and spurious suppression
better than FCC requirements

Modulation AM, 90% typical

Current drain, transmit less than 1.2 amp @ 13.8 VDC

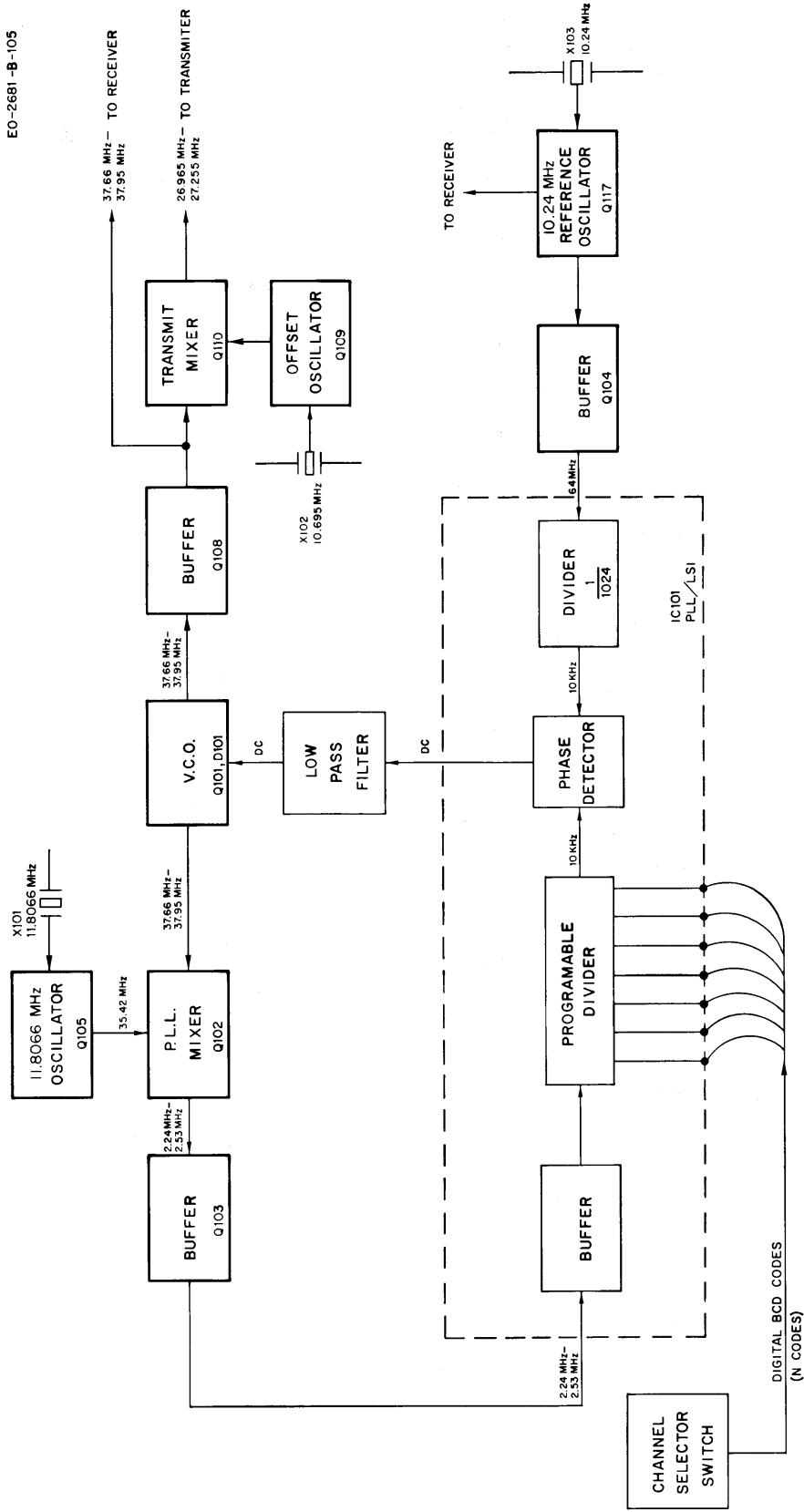

Figure 2-1. Block Diagram of PLL Circuitry

There is now a new DC voltage set up to tune the VCO frequency to 37.950 MHz. When this occurs the loop is considered locked. With the channel selector at 23, the following outputs of the PLL circuitry are produced: the 37.950 MHz VCO output is fed to the First Receiver Mixer, and in the transmit mode, is mixed with the 10.695 MHz output of Q109 to produce a transmit frequency of 27.255 MHz.

N CODE — FREQUENCY CORRELATION CHART

Channel No.	Channel Frequency	"N" Code	V.C.O. Frequency	Channel Switch Output (PLL Inputs)				
				A	B	C	D	A
1	26.965 MHz	224	37.660 MHz	0	0	0	0	0
2	26.975 MHz	225	37.670 MHz	1	0	0	0	0
3	26.985 MHz	226	37.680 MHz	0	1	0	0	0
4	27.005 MHz	228	37.700 MHz	0	0	1	0	0
5	27.015 MHz	229	37.710 MHz	1	0	1	0	0
6	27.025 MHz	230	37.720 MHz	0	1	1	0	0
7	27.035 MHz	231	37.730 MHz	1	1	1	0	0
8	27.055 MHz	233	37.750 MHz	1	0	0	1	0
9	27.065 MHz	234	37.760 MHz	0	1	0	1	0
10	27.075 MHz	235	37.770 MHz	1	1	0	1	0
11	27.085 MHz	236	37.780 MHz	0	0	1	1	0
12	27.105 MHz	238	37.800 MHz	0	1	1	1	0
13	27.115 MHz	239	37.810 MHz	1	1	1	1	0
14	27.125 MHz	240	37.820 MHz	0	0	0	0	1
15	27.135 MHz	241	37.830 MHz	1	0	0	0	1
16	27.155 MHz	243	37.850 MHz	1	1	0	0	1
17	27.165 MHz	244	37.860 MHz	0	0	1	0	1
18	27.175 MHz	245	37.870 MHz	1	0	1	0	1
19	27.185 MHz	246	37.880 MHz	0	1	1	0	1
20	27.205 MHz	248	37.900 MHz	0	0	0	1	1
21	27.215 MHz	249	37.910 MHz	1	0	0	1	1
22	27.225 MHz	250	37.920 MHz	0	1	0	1	1
23	27.255 MHz	253	37.950 MHz	1	0	1	1	1

Table A

Receiver

The receiver is a dual-conversion superheterodyne, receiving AM signals from 26.965 MHz to 27.255 MHz. The operating channel is determined by the PLL frequency synthesizer, which provides the local oscillator frequency to the First Mixer. A variable squelch circuit is included to quiet the receiver between transmissions.

In the receive mode, 13.8 VDC is supplied to IC102, Q114, Q115, Q118, Q119 and to Q106 (the AVR). The AVR supplies regulated voltage to the synthesizer stages and to the Reference Oscillator, Q117. A bias voltage is also applied to the base of the Transmit Switch keeping it open so that the transceiver circuits remain in receive.

Radio signals are received by the antenna and enter the radio at the antenna jack. The filter formed by L109, L110, C152, and C1 matches the antenna impedance to the RF Amplifier. Signals in the 26.965 MHz - 27.255 MHz range are filtered and amplified by the RF Amplifier, L114, and its tuned circuit C154/T104 and T105. D107 is a signal overload protector.

The output of the RF Amplifier and the buffered VCO signal (which in this case could be called the "first local oscillator frequency") are applied to the First Receive Mixer and produce an output of 10.695 MHz, which is the first IF.

The first IF passes through tuned circuits L112 and T106. It is then applied to the Second Receive Mixer, Q116, along with 10.240 MHz from the Reference Oscillator, Q117. The two signals are mixed in the Second Receive Mixer and produce an output of 455 KHz, which is the second IF.

The second IF passes through the Ceramic Filter, CF101, and is amplified by Q118 and Q119. The amplified signal is then fed to the Detector, D110. The Detector establishes an automatic gain control (AGC) voltage and recovers the audio from the modulated signal. The AGC voltage maintains the output volume of the receiver constant under variations in input signal strength and also controls the Squelch Switch, Q102.

The squelch functions in the following manner: in the receive mode, a bias voltage from Q106 is applied to the base of Q120, as determined by RV101. In the absence of a signal the base of Q120 is positively biased and is on. This biases the squelch transistor inside IC102, which turns off the Audio Amplifier and squelches the receiver. When a signal is received, the AGC voltage developed by D110 biases Q120 off. This biases the squelch transistor inside IC102 such that the audio amplifier is turned on and the signal is heard.

The recovered audio from the Detector passes through a series Automatic Noise Limiter (ANL), D108. The output of the ANL goes through the volume control, VR1, and is RC coupled to the Audio Amplifier, IC102. The amplified output from IC102 passes through the audio transformer, T110, to be applied to the speaker jacks and the speaker.

Transmitter

Switching to the transmit mode is accomplished in the following manner: when the PTT switch is closed, the base of the DC Switch, Q107, is grounded. This establishes forward bias which causes Q107 to conduct. Regulated voltage from the Automatic Voltage Regulator (AVR), Q106, is then supplied through Q107 to Q109 and Q110. RF is not applied to Q111, Q112 and Q113.

The operating channel is determined by the PLL frequency synthesizer. The buffered VCO frequency is mixed in Q110 with the 10.695 MHz Offset Oscillator, Q109, output to yield the transmit frequency. The transmit frequency from Q110 passes through the filter circuit of L103, L104, and T102 and is applied to the Pre-driver, Q111. The filter circuit partially removes spurious signals from the transmit frequency.

The Pre-driver, Q111, and the Driver, Q112, form two stages of amplification leading to the final stage. The filter circuit of T103 follows Q111, and L106 follows Q112. These two circuits filter out the remaining spurious signals from the transmit frequency.

From the Driver the signal is applied to the final stage, the RF Power Amplifier, Q113. This is a current amplifier that raises the transmit signal to an output of four watts. Its output is applied to a filter, consisting of L109, C152, L110 and C1, and then to the antenna jack.

The transmit signal is modulated in the following manner: microphone output is applied to the Audio Amplifier, IC102. The output is applied to the collectors of Q112 and Q113 through the audio output transformer, T110. Control voltages for the transmit audio (ALC), Q122, and the Range Boost, Q121, come from the detector diode D111. The transmit audio ALC boosts, or lowers, the amplifier gain in response to line voltage fluctuations. This insures full modulation of the carrier despite any changes in line voltage. The Range Boost reduces AF peaks so that a higher average AF level is supplied to the Audio Amplifier. This gives the desired high average modulation without overmodulation of peaks.

**Noise Blanking
Circuit (2683 only)**

This circuit silences undesirable impulse noises by disabling the receiver circuit for the short time the impulse is applied to the antenna circuit.

When the ANL-NB Switch is in the NB position, a fraction of the noise impulse will be applied to D115 and D116 from the Mixer stage, through C186, and rectified into a DC voltage. The voltage is then applied to the base of the Noise Blanking Amplifier, Q126, which operates the Noise Blanking Switch.

Q125 will also operate causing T107 to short-circuit to ground thereby inactivating the receiver circuit for a short time. C233 determines the cut-off time the receiver will be silenced during reception of noise impulses.

A fraction of the RF power output is applied to Diode, D501, through the inductive/capacitive coupling provided on the p.c. board, PTSR002BOX. This signal is rectified into a DC voltage. The DC voltage is then applied to the meter terminals through the Meter Adjustment Trimmer, RV501, if the Meter Mode Switch, S3, is placed in the CB position. In this way the RF output will be indicated on the meter. When S3 is placed in the CAL position, the DC voltage is switched to the SWR meter calibrating circuit, consisting of R504 on PTSR002BOX and the cal. variable resistor, VR-4, on the front panel. Placing the meter pointer in the SET position on the meter scale by adjusting VR-4, is to predetermine the standard reference level in terms of forward traveling RF power. When S3 is placed in the SWR position, another DC voltage is produced by rectifying the antenna reflection energy applied to Diode D502. The inductive/capacitive coupling circuit is switched to the SWR indication circuit, consisting of RV502, VR-4, and the meter, thus giving the SWR of the antenna system.

**TX Lamp
Circuit
(2683 only)**

When the Switching Transistor, Q107, supplies DC voltage to the transmit circuit, the voltage is also applied to terminal 3 on EPO-0649. This makes Q2 (on EPO-0649) activate. The TX Lamp, PL3, will be lit. The power line of PL3 is connected to the modulation circuit, thus varying the brightness of the lamp during transmission.

**RX Lamp
Circuit
(2683 only)**

When Switching Diode D106 supplies DC voltage to the receive circuit, voltage will be applied to terminal 1 on EPO-0649. This makes the emitter-collector of Q1 conductive and lights the Receiver Lamp, PL2.

**PA Amplifier
and Switch
(2683 only)**

When the PA mode is selected by placing S3 in the PA position, the PA Gate Switch, Q4, is grounded. With Q4 grounded all other functions of the unit except PA are inoperative.

The PA Audio Gate, Q3, functions as an amplifier for the microphone when it is not clamped to AC ground by Q4. The audio signal from the microphone is amplified by Q3 and is then applied to the Audio Amplifier IC102. The audio signal is amplified by IC102 and is then applied to the PA jack, J5.

CHAPTER 3 — ALIGNMENT

General

These procedures must be followed to align the Hy-Gain I, II, and III transceivers, (Models 2681, 2682, and 2683). Alignment should not be undertaken unless the technician has adequate test equipment and a full understanding of the circuitry of the transceiver.

IMPORTANT : Tuning adjustment of these transceivers "shall be made by or under the immediate supervision and responsibility of a person holding a first- or second-class commercial radio operator license", as stipulated in Part 95.97 (b) of the FCC Rules and Regulations.

The procedures are divided into two main sections: Transmitter Alignment and Receiver Alignment. See *Equipment* below for a complete list of recommended equipment.

These procedures assume that proper voltages are present at all points in the unit, if not, troubleshoot before continuing.

NOTE: The ferrite cores in the tuned coils are easily chipped or broken. Always use care when inserting an alignment tool in the coil: insert it straight into the core.

Recommended Tools and Equipment

The following equipment is recommended for use in aligning the Hy-Gain I, II, and III transceivers.

- Audio Signal Generator, 1 KHz
- AC VTVM, 1 mV measurable
- DC Ampere Meter, 2A
- Variable Regulated Power Supply, DC 8-15V, 2A
- Frequency Counter, 0 to 40 MHz, high input impedance type
- VTVM with RF probe
- Oscilloscope, 30 MHz, high input impedance
- RF wattmeter and 50 ohm, 5W dummy load
- Standard RF signal generator, 27 MHz CB band
- Speaker dummy resistor, 8 ohm, 5W
- VOM 20k ohm/V

All test equipment should be properly calibrated.

NOTE: Test voltage is DC 13.8V unless otherwise specified.

Transmitter Alignment Procedure

Equipment Set-up

Refer to Figure 3-4 for the location of components to be adjusted for transmitter alignment.

Connect test equipment as shown below.

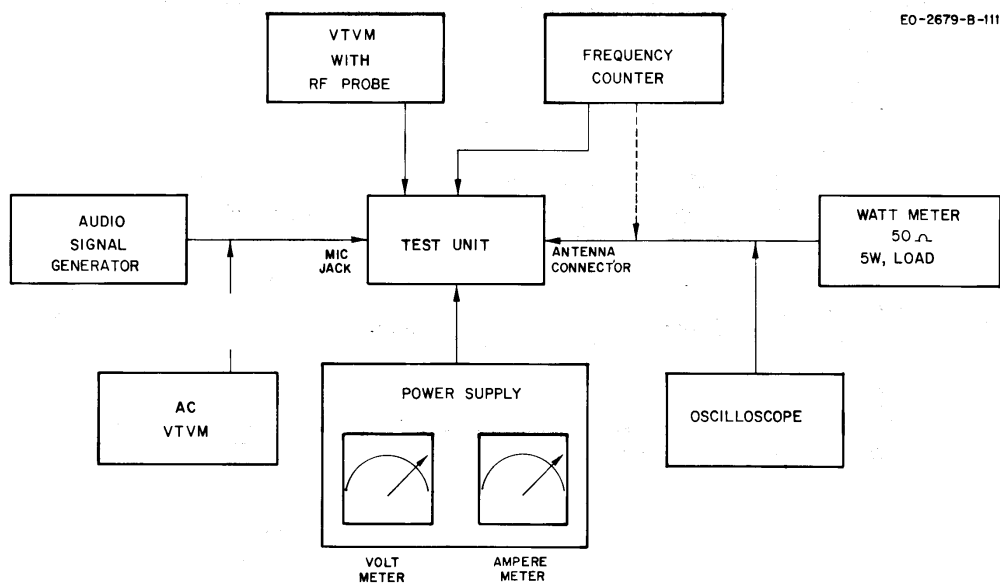

Figure 3-1. Equipment Set-up, Transmitter Alignment

Pre-Alignment Frequency Check

Before alignment, use the frequency counter through a 1000 pF coupling capacitor connected in series with the counter input probe to check the operating frequencies at the following points.

Pin 3 of IC101, reference input, check to read 10.24 MHz accurate to significant digits.

Q108 base, transceiver on Ch. 1, check to read 37.66 MHz accurate to four significant digits.

VCO Alignment

1. Connect VOM (DC 10V ranged) across C135 and check to read 5.0V - 5.5V.
2. Place the channel selector in the channel 1 position.
3. Connect the VOM between ground and R114 (TP-8 side).
4. Adjust T101 to obtain $1.5V \pm 1V$.
5. Place the channel selector in the open channel position. A voltage reading of 5.1 to 5.4V is obtained.
6. Place the channel selector in the channel 23 position and read the value in the meter. It should be $2.7 \pm 0.6V$.

RF Output Adjustment

1. Adjust the power supply voltage to 8.0 volts.
2. Connect the VTVM RF probe between the base of Q111 and ground.

3. Set the transceiver channel selector to channel 13. Perform the following procedure on channel 13.
4. Key the transmitter.
5. Adjust the slugs of L103, L104 and T102 for a maximum reading on the VTVM.
6. Connect the VTVM RF probe between the base of Q112 and ground.
7. Adjust the slug of T103 for a maximum reading on the VTVM.
8. Adjust L109, L110 for maximum RF power output as indicated on the wattmeter.
9. Raise the power supply voltage to 13.8V.
10. Repeat steps 2 thru 8.
11. Repeat step 8 until no further improvement is noted.
12. Back off L110 (counterclockwise) for a reading of 4.0 watts RF power output.
13. Readjust L109 for maximum power out.
14. Repeat steps 12 and 13 until the maximum power output is 4.0 watts with L109 peaked for maximum output. Total transceiver current at this setting should not exceed 1.35A.

Transmitter Frequency Check

1. Turn the transceiver off.
2. Connect the dummy load and frequency counter to the antenna jack as shown below:

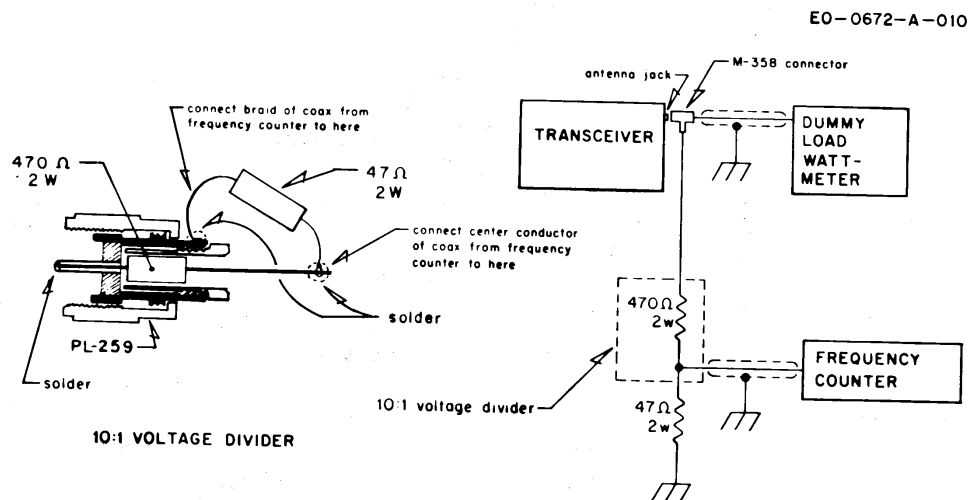

Figure 3-2. Connection of Frequency Counter and Dummy Load

3. Key the transmitter with the microphone PTT button.
4. Check the frequency of each channel with the chart below, frequencies should be within 800 Hz at 25°C.

CHANNEL FREQUENCY

Channel	MHz	Channel	MHz
1	26.965	13	27.115
2	26.975	14	27.125
3	29.985	15	27.135
4	27.005	16	27.155
5	27.015	17	27.165
6	27.025	18	27.175
7	27.035	19	27.185
8	27.055	20	27.205
9	27.065	21	27.215
10	27.075	22	27.225
11	27.085	23	27.255
12	27.105		

Modulation Sensitivity Alignment

1. Place the unit in the transmit mode and apply a 20 mV, 1KHz signal to wire wrap pin 22 on the radio PC board.
2. Adjust RV-102 to obtain 90% modulation as observed on the oscilloscope.
3. Decrease the signal input to 6 mV. Modulation should not fall below 80%.

Receiver Alignment Procedure

Refer to Figure 3-5 for the location of components to be adjusted for receiver alignment.

Equipment Set-up

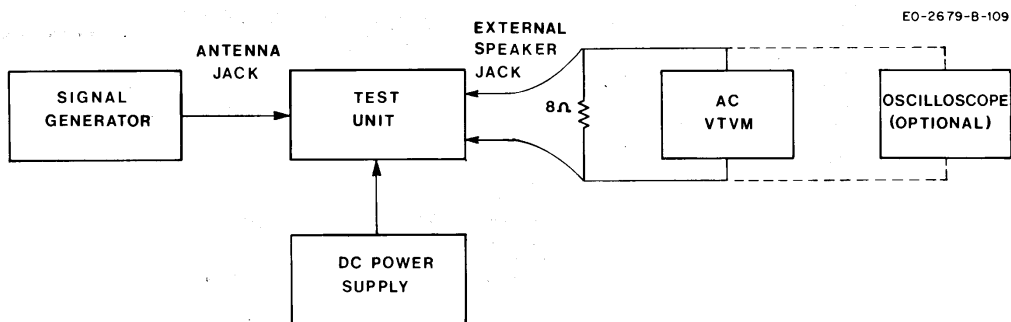

Figure 3-3. Equipment Set-up, Receiver Alignment

Receiver Alignment

1. Set the Signal Generator to 27.115 MHz, 30% 1 KHz, modulation and set the transceiver to channel 13.

NOTE: This alignment should be performed with an extremely small signal input from the signal generator to avoid inaccurate alignment due to AGC action.

2. Adjust T104, T105, L112, T106, T107, T108 and T109 for maximum audio output as indicated on the AC VTVM (or oscilloscope if used).

Tight Squelch Adjustment

1. Set the signal generator to provide an RF input signal of 50 μ V, (1 KHz, 30% mod.).
2. Rotate the squelch control fully clockwise.
3. Adjust RV-101 so that the squelch just breaks with the 50 μ V signal input.

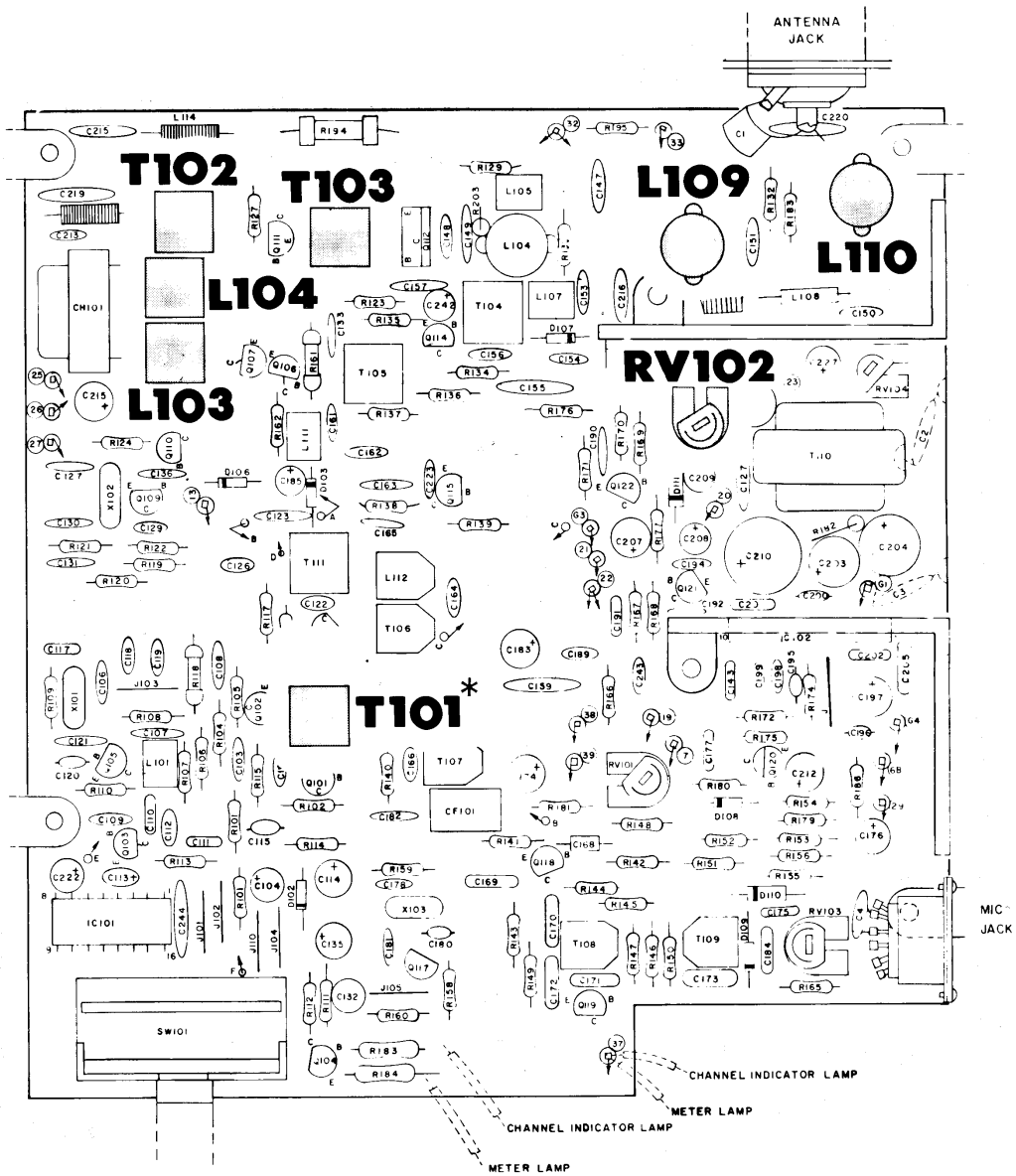

*NOTE: T101 is adjusted for VCO alignment only.

Figure 3-4. Components Adjusted for Transmitter Alignment

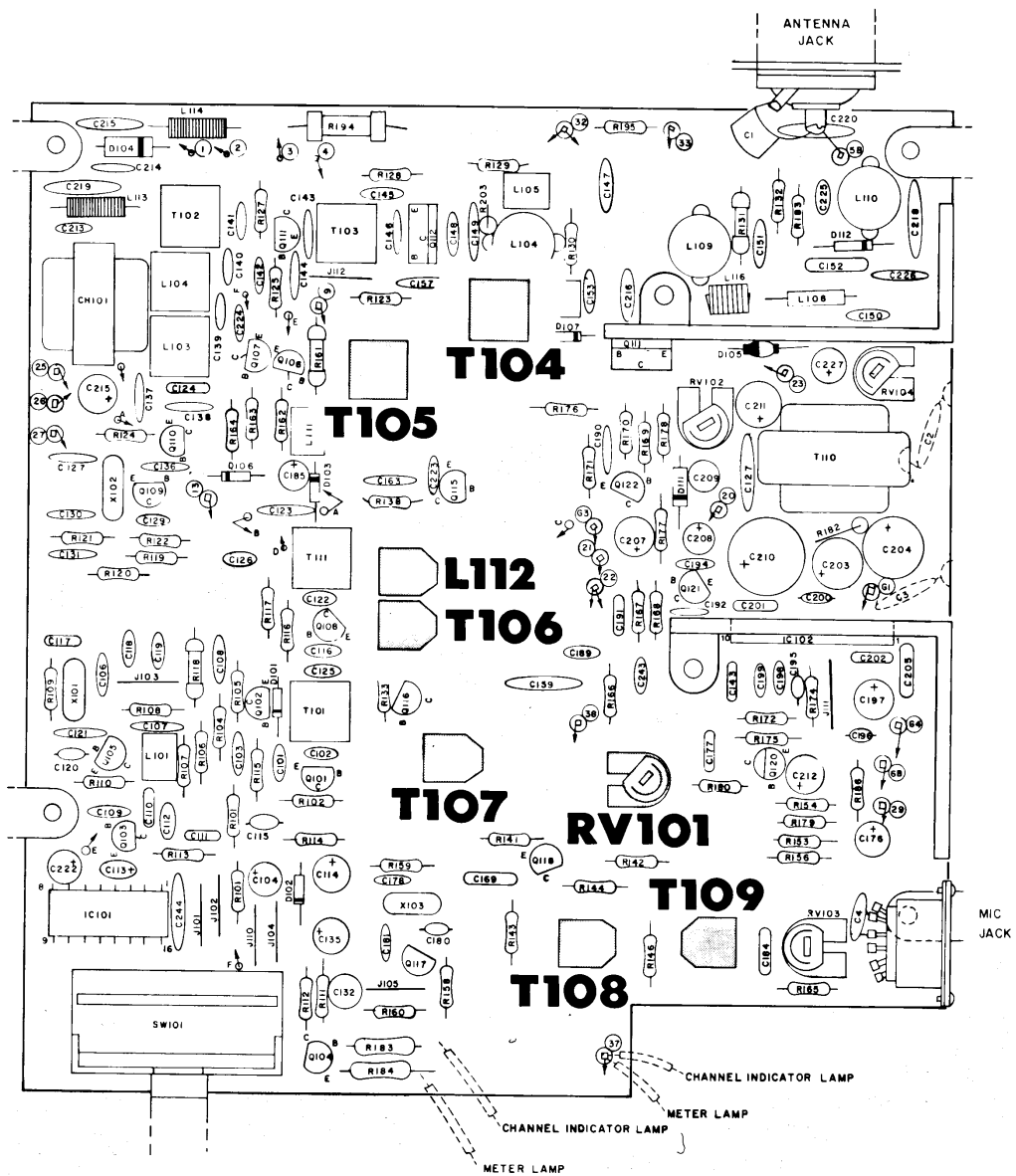

Figure 3-5. Components Adjusted for Receiver Alignment

CHAPTER 4 — CHARTS AND DRAWINGS

Voltage Measurement Charts
Models 2681, 2682, 2683

VOLTAGE MEASUREMENT CHART

Ref. Desig.	Mode	E	B	C
Q101	RX	0	.70V	2.25V
	TX	0	.70V	2.25V
Q102	RX	0	.66V	2.77V
	TX	0	.66V	2.77V
Q103	RX	0	.65V	2.12V
	TX	0	.65V	2.12V
Q104	RX	0	.65V	2.17V
	TX	0	.65V	2.17V
Q105	RX	2.46V	3.09V	3.91V
	TX	2.46V	3.09V	3.91V
Q106	RX	8.66V	9.34V	12.54V
	TX	8.66V	9.34V	12.54V
Q107	RX	8.67V	8.13V	.39V
	TX	8.75V	8.05V	8.68V
Q108	RX	.78V	0	3.98V
	TX	.78V	0	3.98V
Q109	RX	0	.31V	.31V
	TX	2.7V	2.8V	4.45V
Q10	RX	0	0	.37V
	TX	1.9V	2.6V	8.8V
Q111	RX	1.76V	2.49V	13.66V
	TX	1.7	2.4	13.5V
Q112	RX	0	0	13.38V
	TX	0	0	11.0V
Q113	RX	0	0	13.4V
	TX	0	0	11.8V
Q114	RX	1.55V	2.20V	12.71V
	TX	.38	.38V	13.0V
Q115	RX	1.54V	2.25V	12.09V
	TX	8.1V	.47V	13.25V
Q116	RX	0	.61V	0
	TX	0	.61V	0
Q117	RX	2.07V	2.64V	3.54V
	TX	2.07V	2.64V	3.54V
Q118	RX	1.48V	2.17V	12.11V
	TX	.1V	.35V	13V
Q119	RX	.57V	1.26V	12.68V
	TX	.15V	.25V	13V
Q120	SQ	0	.03V	6.68V
	UNSQ	0	.66V	.07V
Q121	RX	0	0	0
	TX	0	0	0
Q122	RX	0	.6V	0
	TX	0	.6V	0
Q125	RX	.48V	0	0
	TX	.48V	0	0
Q126	RX	0	0	0
	TX	0	0	0

IC 102 (BA 521)

Pin No.	1	2	3	4	5	6	7	8	9	10
Squelched	12.69V	0V	0V	6.76V	6.58V	2.45V	.10V	13.61V	13.64V	13.71V
Unsquelched	6.82V	0V	1.28V	6.67V	6.67V	6.70V	.98V	8.06V	13.39V	13.7V

IC 101 (P.L.L. 02A)

Pin. No.	Voltage	Channels Selected
1	4.7	N/A
2	1.8	N/A
3	2.8	N/A
4	4.6	N/A
5	1.5 - 2.5	All Channels
6	4.2	N/A
7	0	N/A
8	4.7	N/A
9	4.7	N/A
10	4.7	N/A
11	4.7	14, 15, 16, 17, 18, 19, 20, 21, 22, 23
12	4.7	8, 9, 10, 12, 13, 20, 21, 22, 23
13	4.7	4, 5, 6, 7, 11, 12, 13, 17, 18, 19, 23
14	4.7	3, 6, 7, 9, 10, 12, 13, 16, 19, 22
15	4.7	2, 5, 7, 8, 10, 13, 15, 16, 18, 21, 23
16	0	N/A

**Front Panel Lamp Controller
P.C. Board (Model 2683 only)**

Ref.	Desig.	Mode	E	B	C
Q1	RX		0	0.7	0
	RX		0	0.7	12
Q2	RX		0	0	13
	TX		0	0.7	0
Q3	RX		0	0	0
	TX		0	0	0
Q4	RX		0	0.6	0
	TX		0	0.6	0

NOTES:

1. This voltage chart is applicable to models 2681, 2682 and 2683. Use the chart for the active components that are present in the model being tested.
2. All voltage are taken with the power source set at exactly 13.8 VDC.