

This Information Is Provided By
CBTricks.com

How to install the Palomar RFX85
on Uniden Bearcat 880

Liability of damages to any equipment is the sole responsibility of the user!
Downloading, viewing, or using any information provided on these pages
automatically accepts the user to the terms of this agreement!
Modifications are provided for information purposes only!
Supporters of CBTricks.com paid for the hosting so you would have this file.

CBTricks.com is a non-commercial personal website was created to help promote the exchange of service, modification, technically oriented information, and historical information aimed at the Citizens Band, GMRS (CB "A" Band), MURS, Amateur Radios and RF Amps.

CBTricks.com is not sponsored by or connected to any Retailer, Radio, Antenna Manufacturer or Amp Manufacturer, or affiliated with any site links shown in the links database. The use of product or company names on my web site is not endorsement of that product or company.

The site is supported with donations from users, friends and selling of the Site Supporters DVD's to cover some of the costs of having this website on the Internet instead of relying on banner ads, pop-up ads, commercial links, etc. Thus I do not accept advertising banners or pop-up/pop-under advertising or other marketing/sales links or gimmicks on my website.

All the money from donations is used for CBTricks.com I didn't do all the work to make money (I have a day job). This work was not done for someone else to make money also, for example the eBay CB sellers.

All Trademarks, Logos, and Brand Names are the property of their respective owners.
This information is not provided by, or affiliated in any way with any radio or antenna Manufacturers.

Thank you for any support you can give.

For information on how to Support CBTricks.com
webmaster@cbtricks.com

The user is solely responsible for making sure that any modifications made to the radio unit must meet all Federal and State Regulations or the Country of use! Liability of damages to any equipment is the sole responsibility of the user! Downloading, viewing, or using any information provided on these pages automatically accepts the user to the terms of this agreement! Modifications are provided for information purposes only! Disclaimer: CBTricks.com does not warrant the accuracy of the information contained herein nor is it responsible for any errors or omissions and assumes no liability for the content on this site. While CBTricks.com uses reasonable efforts to include accurate and up to date information, CBTricks.com makes no warranties or representations as to its accuracy or timeliness and assumes no liability or responsibility for any errors or omissions in the content of this site.

RFX85 Installation on the Uniden Bearcat 880

1. Confirm that the radio works properly before attempting this modification! Once you have confirmed that the radio works properly remove the top and bottom covers and proceed to the step 2.
2. Remove the following parts: L100, L200, L201, L204, Final Transistor (2SC2078). Also remove the chip capacitors that are pointed out in Figure 1. There are 4 chip capacitors total that are removed.

Figure 1

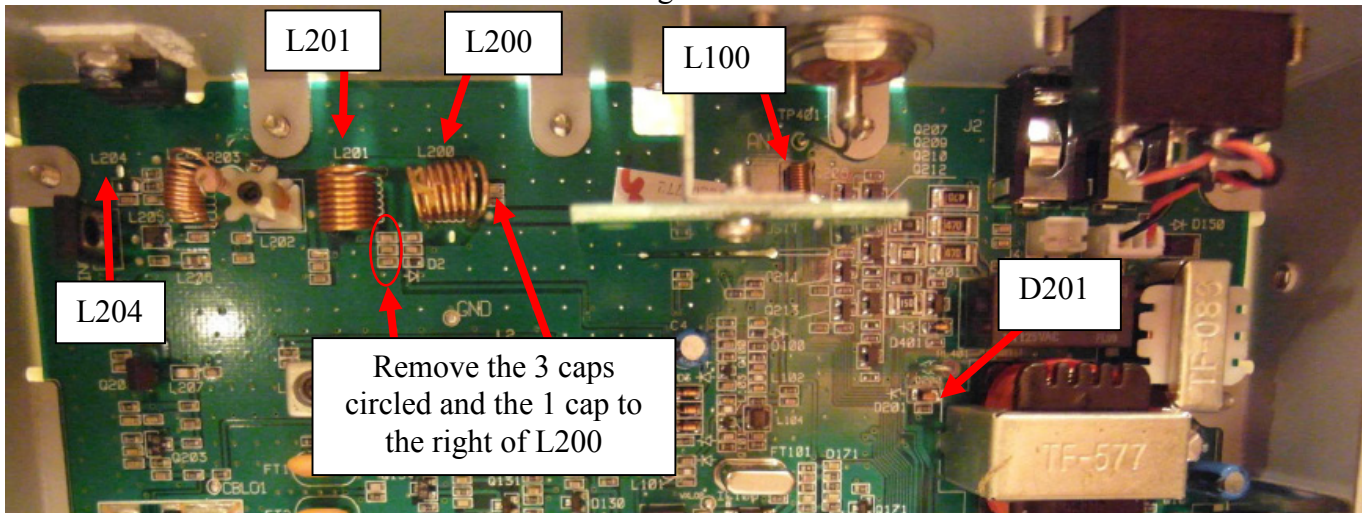

3. Next install a jumper wire in place of L200 (see Figure 2)
4. Solder the RFX85 red coax center conductor to the jumper that you installed at L200. Solder the shield to ground as in Figure 2.

Figure 2

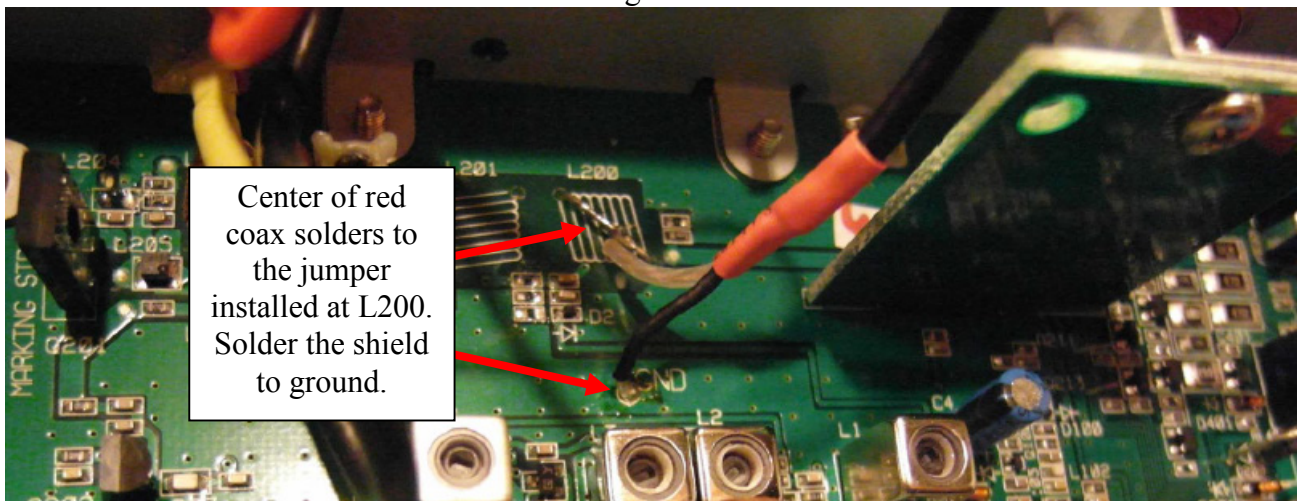

The user is solely responsible for making sure that any modifications made to the radio unit must meet all Federal and State Regulations or the Country of use! Liability of damages to any equipment is the sole responsibility of the user! Downloading, viewing, or using any information provided on these pages automatically accepts the user to the terms of this agreement! Modifications are provided for information purposes only! Disclaimer: CBTricks.com does not warrant the accuracy of the information contained herein nor is it responsible for any errors or omissions and assumes no liability for the content on this site. While CBTricks.com uses reasonable efforts to include accurate and up to date information, CBTricks.com makes no warranties or representations as to its accuracy or timeliness and assumes no liability or responsibility for any errors or omissions in the content of this site.

5. Route the RFX85 orange wire and yellow coax cable thru the hole where the final was removed and solder them on the back of the board as shown in figure 3.

Figure 3

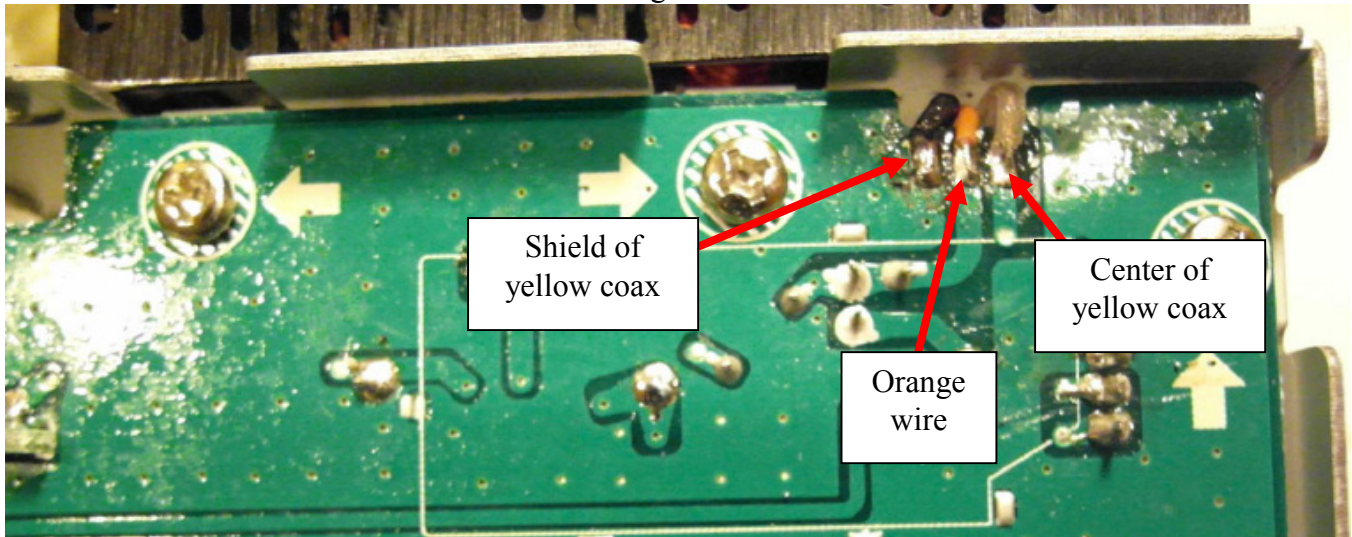

6. Solder the red and black wires from the RFX85 to the back of the radio's DC input jack (not shown).
7. Cut the blue wire and yellow wire off the RFX85.
8. Drill and mount the RFX85 to the back of the radio.
9. Optional: You can remove the limiter by deleting D201 (shown in Figure 1) since there is no adjustment for the AMC.
10. After confirming that you have finished all steps properly test the RX and TX and retune as needed.

The user is solely responsible for making sure that any modifications made to the radio unit must meet all Federal and State Regulations or the Country of use! Liability of damages to any equipment is the sole responsibility of the user! Downloading, viewing, or using any information provided on these pages automatically accepts the user to the terms of this agreement! Modifications are provided for information purposes only! Disclaimer: CBTricks.com does not warrant the accuracy of the information contained herein nor is it responsible for any errors or omissions and assumes no liability for the content on this site. While CBTricks.com uses reasonable efforts to include accurate and up to date information, CBTricks.com makes no warranties or representations as to its accuracy or timeliness and assumes no liability or responsibility for any errors or omissions in the content of this site.