

POWER METER

GENERAL DESCRIPTION:

The Power Meter is a high quality, compact, easy to install instrument. It will measure the VSWR of an antenna directly on the meter without an inter-polation chart, percentage of modulation to over 100% and power output in 3 ranges up to 500 W.

The Power Meter was designed for maximum operating convenience and as such consists of two parts. The modern style Indicator unit can be placed in a convenient position while the Sensor, which is placed in the line between the transceiver and the antenna, can stand or hang behind the transceiver. This alleviates the need to run coaxial cables across the operating desk. The Indicator and Sensor units are hooked together with the inter-connection cable supplied.

MECHANICAL SPECIFICATIONS:

Height..... 3"
Width..... 7"
Depth..... 5 1/8"
Net Weight..... 1 1/2 lbs.
Construction..... Lightweight aluminum chassis with rugged steel case.
Total Shipping Weight..... 3 1/4 lbs.

ELECTRICAL SPECIFICATIONS:

Impedance..... 50 Ohms Input and Output
Connector Data..... Sensor and Indicator hooked together with 4 foot cable supplied
Power Ranges..... Three power ranges from 0 to 10, 100 and 500 watts
Modulation..... Measures percentage of modulation to over 100%
VSWR..... Measures VSWR of antenna
Frequency Range..... 3-60 MHz

ASSEMBLY & INSTALLATION:

() Carefully remove the Indicator and Sensor units from the packing carton. Examine it closely for signs of shipping damage. *See last paragraphs in this manual.

() Connect the Sensor unit between the Transceiver and antenna, being careful to connect the coaxial connector on the short length of coaxial cable to the output of the Transceiver. Connect the antenna to the SO-239 socket on the Sensor.

VSWR OF ANTENNA:

Assuming that the Power Meter has been installed as outlined above, proceed as follows to measure the VSWR of the antenna. Rotate the Calibrate control fully counter-

clockwise, switch the Function Switch to FWD (forward), key the Transceiver and advance the Calibrate control until the meter reads full scale (just to the end of the calibrated scales, no further). Switch the Function Switch to SWR and the VSWR of the antenna can be read directly from the SWR scale. Unkey the Transceiver.

PERCENTAGE OF MODULATION:

Before measuring the percentage of modulation, check the VSWR of the antenna as outlined above. The VSWR should be less than 1.5 to 1 for the percentage of modulation to be correct (it will indicate modulation with a higher VSWR but not accurately).

Set Function Switch to FWD, Calibrate full counter-clockwise, key the Transceiver. Advance the Calibrate control to full scale deflection, switch the Function Switch to MOD. Talking or whistling into the microphone will now give a percentage of modulation on the meter. Adjust the distance between the microphone and the mouth so that on words like "five" the percentage of modulation does not exceed 100%. Unkey the Transceiver.

POWER OUTPUT:

The Power Meter will measure, using three ranges, the power output up to 500 watts. The VSWR should be less than 1.5 to 1 for this measurement to be accurate.

When measuring the power output always start on the highest range (500w) and then go down until a reading is obtained, do not let the meter be pinned full scale. The Calibrate control does not operate in the power position.

NOTE

The Power Meter power scales are a factory adjustment internally and should not be adjusted.

RETURNING THE EQUIPMENT FOR SERVICE:

DO NOT ship equipment to the Manufacturer without prior authorization. We prefer to send special shipping labels which will avoid the delay of unexpected shipment.

If time is extremely important, wire or call for approval and we will rush labels to you. When a shipment is expected, even the time of sending the labels is less than that lost when an unexpected shipment is received.

It is VERY IMPORTANT that the shipment be well packed and fully insured. Damage claims must be settled between you and the carrier and will greatly delay any returns. Proper packing normally avoids this trouble.

ALL SHIPMENTS MUST BE SENT TO US PREPAID. We do not accept collect shipments. All returns should be made in our standard cartons only - so save your carton when un-

packing the unit. When a shipment is returned it will be handled in one of three ways...

1.---Where all service is in warranty the shipment will be returned with transportation costs collected by the carrier on arrival.

2.---If there are any charges not covered by warranty, we will hold the shipment and advise you of costs which you can then send. The shipment will arrive with only transportation costs collected by the carrier on arrival.

3.---Or upon your written authorization, we will ship C.O.D. for any charges not covered by warranty; then the carrier will collect these charges, and the transportation costs on arrival. Unclaimed or refused C.O.D. shipments will not be reshipped until payment of service and transportation charges is received. Shipment will then be made collect for reshipment transportation charges. Unclaimed equipment automatically becomes the property of the Manufacturer 60 days after date of refusal or return and will be disposed of for payment of charges due.

NOTE

We WILL NOT ship by means of a carrier that will not fully insure the shipment. Some carriers have a \$200.00 limit. The exception to this is when there is no other means (APO-FPO-etc.) of shipment than parcel post, and then we will ship by this means with your written agreement that you assume any loss over that which the carrier will insure. C.O.D. shipments cannot be made to APO-FPO addresses.

REPLACEMENT OF PARTS ORDERING:

All replacement parts orders must be prepaid or C.O.D. only.

Replacement part price quotes will be furnished on request for those who desire prepaid shipment or cannot accept C.O.D. shipments.

WARRANTY

Hy-Gain Electronics Corporation warranty each new product manufactured to be free from defects in material and workmanship and agrees to remedy any such defect, or to furnish a new part, in exchange for any part of any unit which under normal installation, use, and service discloses such defect within ninety days from the date of purchase by original owner.

This warranty does not extend to any of our products which have been subjected to mis-use, neglect, accident, incorrect wiring not our own, improper installation or to use in violation of instructions furnished by us. Nor does it extend to units which have been repaired or altered outside of our factory nor to accessories used therewith not of our own manufacture.

Hy-Gain Electronics Corporation reserves the right to make any changes deemed necessary or desirable without advance notice or incurring any obligation to make like changes in units previously manufactured or sold.

This warranty does not cover transportation or installation costs that may be incurred. Hy-Gain Electronics Corporation's sole liability is remedy of any defect for ninety days. Hy-Gain Electronics Corporation is not responsible

for personal injury or property damage resulting from improper or careless installation or usage not intended by the manufacturer.

No person is authorized to assume for us any other liability in connection with the sale of our products.

All warranties are void and terminated one year after the last unit of its type and design has been manufactured by us.

All claims of defect or shortage should be addressed to:

Hy-Gain Electronics Corporation
Attention: Customer Service Department
R.R. #3
Lincoln, Nebraska 68505

You must furnish model number, date, place and proof of purchase, such as a copy of the sales receipt to establish warranty. Your letter should include all pertinent details along with part or item numbers involved. Do Not return anything until requested to do so. No warranty card is furnished. You must supply the above information.

Any returned items must have prior authorization. Unexpected returns are greatly delayed in handling. These delays can be avoided by writing in advance furnishing the above information.

ALIGNMENT:

All internal adjustments of the 421A were made at the factory prior to shipment. The accuracy of the meter is dependent upon the adjustment of these controls and do not require any further adjustment. No attempt should be made to disturb the settings unless precision test equipment is used. If internal adjustments are to be attempted the following test equipment must be used.

A 50 ohm resistive dummy load capable of 500 watts continuous duty, an accurate RF voltmeter equivalent to the Hewlett Packard 410-B or 410-C, a transmitter with variable output to at least 500 watts on 30 MHz, and an insulated alignment tool.

Remove the covers from the indicator and sensor units.

NULL ADJUSTMENT:

Connect the short length of cable from the sensor unit to the transmitter. Using a piece of coaxial 50 ohm cable, connect the dummy load to the SO-239 socket on the sensor.

Switch the indicator unit to FWD, key the transmitter and adjust the Calibrate control for full scale, switch to SWR and if any reflected power is present, adjust the piston trimmer, in the sensor, for a minimum. Unkey.

POWER ADJUSTMENT:

Switch the 421A to the 10 watt position. With the RF volt meter connected across the dummy load, apply power and increase it until exactly 22 volts RMS is across the load. Adjust the small trimmer pot (R1), see reverse side of circuit board, so that the 421A reads exactly 10 watts.

Switch to the 100 watt range and increase power until the volt meter reads 70 volts RMS. Adjust the center pot (R2) until the 421A reads 100 watts.

Switch to the 500 watt range and increase the power until the volt meter reads 158 volts RMS. Adjust the trimmer pot (R3) until the 421A reads 500 watts.

PARTS LIST

Item	Description	Part No.
R1	20K PCM Trimmer	721483
R2	50K PCM Trimmer	721487
R3	100K PCM Trimmer	720042
R4	120K 1/2w 10% Resistor	721335
R5	47K 1/2w 10% Resistor	721291
R6	8.2K 1/2w 10% Resistor	721345
R7	1.8K 2w 10% Resistor	721104
R8	3.3K 5% Resistor	721321
R9	180 2w 10% Resistor	722223
R10	25K Lin Variable Resistor	705720
D1	1N270 Diode	765722
D2	1N270 Diode	765722
D3	1N34 Diode	765668
D4	1N34 Diode	765668
C1	1 - 8 Pf Piston Trimmer	721861
C2	68 Pf Disc Ceramic	721601
C3	68 Pf Disc Ceramic	721601
C4	.1 Film Cap	721574
C5	.001 Disc Ceramic	721158
C7	.1 Film Capacitor	721574
C8	.001 Disc Ceramic	721158
C9	.001 Disc Ceramic	721158
C10	.001 Disc Ceramic	721158
C11	.01 Disc Ceramic	721550
M1	Multifunction Meter	795643
S1	Function Switch	700309
T1	Sensing Toroid	722077
T2	Modulation Transformer	735623
RFC1	2.5 mh Choke	721907

Printed in USA

PN 800472

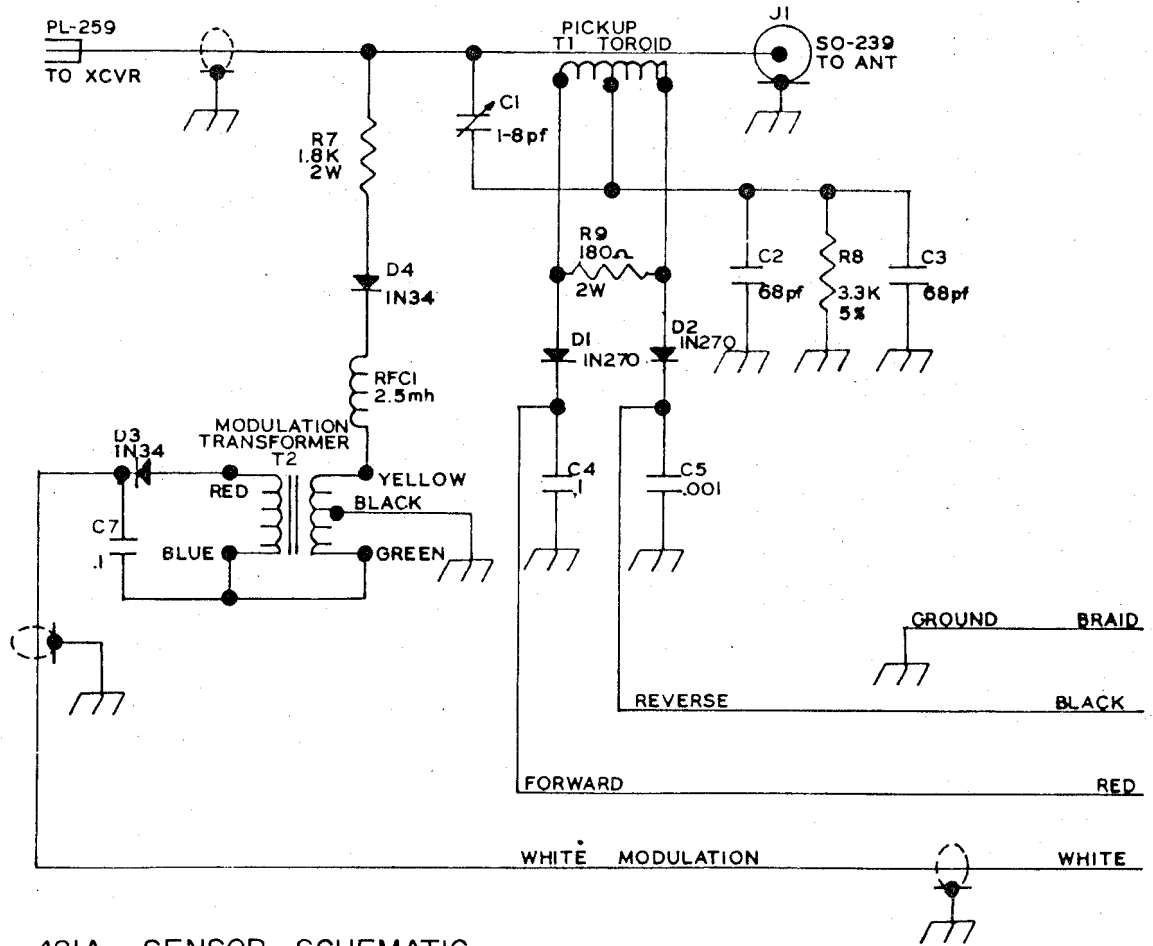

421A. SENSOR SCHEMATIC

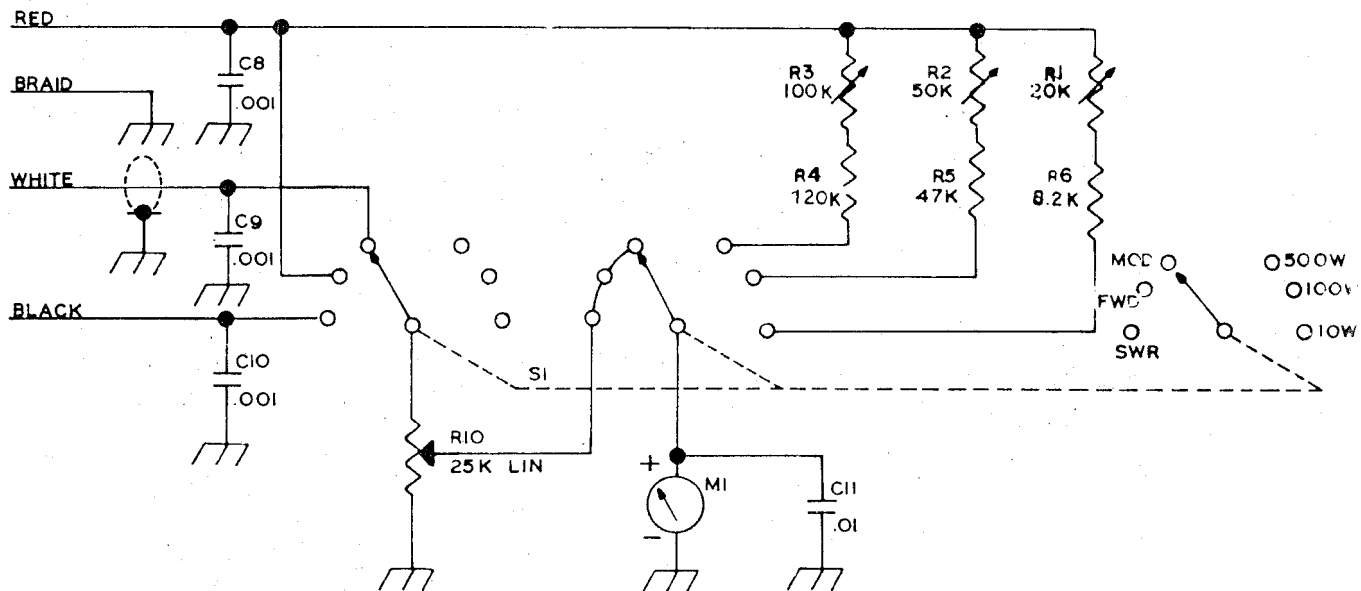

421A INDICATOR SCHEMATIC