

# HEATHKIT<sup>®</sup> MANUAL

*for the*

**LINEAR AMPLIFIER**

**Model SB-220**

595-1122-16



HEATH COMPANY • BENTON HARBOR, MICHIGAN

## HEATH COMPANY PHONE DIRECTORY

The following telephone numbers are direct lines to the departments listed:

Kit orders and delivery information ..... (616) 982-3411  
Credit ..... (616) 982-3561  
Replacement Parts ..... (616) 982-3571

### *Technical Assistance Phone Numbers*

*8:00 A.M. to 12 P.M. and 1:00 P.M. to 4:30 P.M., EST, Weekdays Only*  
R/C, Audio, and Electronic Organs ..... (616) 982-3310  
Amateur Radio ..... (616) 982-3296  
Test Equipment, Weather Instruments and  
Home Clocks ..... (616) 982-3315  
Television ..... (616) 982-3307  
Aircraft, Marine, Security, Scanners, Automotive,  
Appliances and General Products ..... (616) 982-3496  
Computers ..... (616) 982-3309

## YOUR HEATHKIT 90-DAY LIMITED WARRANTY

For a period of ninety (90) days after purchase, Heath Company will replace or repair free of charge any parts that are defective either in materials or workmanship. You can obtain parts directly from Heath Company by writing us at the address below or by telephoning us at (616) 982-3571. And we'll pay shipping charges to get those parts to you — anywhere in the world.

We warrant that during the first ninety (90) days after purchase, our products, when correctly assembled, calibrated, adjusted and used in accordance with our printed instructions, will meet published specifications.

If a defective part or error in design has caused your Heathkit product to malfunction during the warranty period through no fault of yours, we will service it free upon proof of purchase and delivery at your expense to the Heath factory, any Heathkit Electronic Center, or any of our authorized overseas distributors.

You will receive free consultation on any problem you might encounter in the assembly or use of your Heathkit product. Just drop us a line or give us a call. Sorry, we cannot accept collect calls.

Our warranty does not cover and we are not responsible for damage caused by: incorrect assembly, the use of corrosive solder, defective tools, misuse, or fire; or by unauthorized modifications to or uses of our products for purposes other than as advertised. Our warranty does not include reimbursement for inconvenience, loss of use, customer assembly or set-up time.

This warranty covers only Heathkit products and is not extended to allied equipment or components used in conjunction with our products. **We are not responsible for accidental or consequential damages.** Some states do not allow the exclusion or limitation of incidental or consequential damages, so the above limitation or exclusion may not apply to you. This warranty gives you specific legal rights, and you may also have other rights which vary from state to state.

If you are not satisfied with our service (warranty or otherwise) or with our products, write directly to our Director of Customer Services, Heath Company, Benton Harbor, Michigan 49022. He will make certain your problems receive immediate, personal attention.

HEATH COMPANY  
BENTON HARBOR, MI. 49022

The Heath Company reserves the right to discontinue products and to change specifications at any time without incurring any obligation to incorporate new features in products previously sold.

Assembly  
and  
Operation  
of the



# LINEAR AMPLIFIER

MODEL SB-220



HEATH COMPANY  
BENTON HARBOR, MICHIGAN 49022

## TABLE OF CONTENTS

INTRODUCTION . . . . .	3
PARTS LIST . . . . .	5
STEP-BY-STEP ASSEMBLY . . . . .	9
Circuit Board . . . . .	10
Circuit Board Prewiring . . . . .	11
Input Coil Assembly . . . . .	12
Front Panel . . . . .	20
Chassis . . . . .	24
Chassis Parts Mounting . . . . .	24
ALC Wiring . . . . .	27
Top-Chassis Assembly . . . . .	28
Under-Chassis Wiring . . . . .	46
120-240 Volt Wiring . . . . .	55
Final Top-Chassis Wiring . . . . .	56
Cable Preparation . . . . .	58
Knob Installation . . . . .	59
TEST AND FINAL ASSEMBLY . . . . .	61
INSTALLATION . . . . .	65
OPERATION	
Controls, Connectors, And Meters . . . . .	69
General . . . . .	70
Tune-Up . . . . .	71
Periodic Maintenance . . . . .	74
IN CASE OF DIFFICULTY . . . . .	75
Troubleshooting Chart . . . . .	76
Special Shipping Instructions for U.S. and Canada . . . . .	78
SPECIFICATIONS . . . . .	79
CIRCUIT DESCRIPTION	
Power Supply . . . . .	81
Relay . . . . .	82
RF Circuits . . . . .	83
ALC Circuit . . . . .	83
Metering Circuits . . . . .	84
CIRCUIT BOARD X-RAY VIEW . . . . .	85
CHASSIS PHOTOGRAPHS . . . . .	86
SCHEMATIC. . .(fold-out from page) . . . . .	87
WARRANTY . . . . .	Inside front cover
CUSTOMER SERVICE . . . . .	Inside rear cover

# INTRODUCTION

The Heathkit Model SB-220 Linear Amplifier is a completely self-contained, table top, grounded grid, linear amplifier. It is designed to operate at the maximum amateur power limit on SSB, CW, and RTTY. Its styling matches the Heath SB series of amateur equipment.

The Amplifier is designed to be used with exciters which deliver 100 watts or more output. It can be used with less driving power, but will give a lower output.

A broad-band, tuned input circuit for each band feeds the two Eimac 3-500Z triode tubes connected in grounded grid configuration. The tubes are biased beyond cut-off in the receive mode, and zener-regulated bias controls the idling current in the transmit mode. The tubes are cooled by a fan.

An ALC circuit develops negative voltage to be fed back to the exciter to reduce its gain when the Amplifier is overdriven.

The antenna change-over relay is normally actuated by exciter relay contacts to place the Amplifier in the transmit mode.

The Amplifier can be operated from either 120 VAC or 240 VAC 50/60 Hz lines and can be easily changed from one to the other. Operation from a 240 volt line is recommended. Each side of the line cord is equipped with a circuit breaker to protect against overloads.

An important feature of this Amplifier is that it can be tuned up at the one kilowatt limit and can then be switched to operate on SSB at two kilowatts P.E.P. input. As the switching changes both the voltage and current to the final tubes, the impedance remains the same and no additional adjustment of tuned circuits is required.

The tubes are "instant heating" types, and transmission may be started as soon as the Amplifier is switched on (after tune-up).

Here is a full legal-limit Amplifier that can take its place on your operating table and give you years of trouble-free pleasure. This Amplifier has a commanding voice.

**Read the "Kit Builders Guide" for complete information on unpacking, parts identification, tools, wiring, soldering, and step-by-step assembly procedures.**

# PARTS LIST

This Parts List contains all of the parts used in the assembly of the kit. Some parts are packaged in envelopes with the part number of the contents printed on the outside. Except for the initial parts check, retain these parts in their envelopes until they are called for in the assembly steps.

Check each part against the following list. The key numbers correspond to the numbers on the Parts Pictorial (fold-out from Pages 4 and 7).

To order a replacement part, refer to the "Parts Order Form" furnished with this kit. If a Parts Order Form is not available, refer to "Replacement Parts" inside the rear cover of the Manual. For pricing information, refer to the separate "Heath Parts Price List."

KEY PART No.	PART No.	PARTS Per Kit	DESCRIPTION
<b>RESISTORS</b>			
<b>1/2 Watt</b>			
1	1-9	1	1000 $\Omega$ (brown-black-red)
	1-44	2	2200 $\Omega$ (red-red-red)
	1-18	1	5600 $\Omega$ (green-blue-red)
	1-22	1	22 k $\Omega$ (red-red-orange)
	1-23	1	27 k $\Omega$ (red-violet-orange)
	1-24	1	33 k $\Omega$ (orange-orange-orange)
	1-25	1	47 k $\Omega$ (yellow-violet-orange)
	1-26	1	100 k $\Omega$ (brown-black-yellow)
<b>Other Resistors</b>			
2	1-8-1	1	68 k $\Omega$ 1 watt (blue-gray-orange)
	1-38-1	3	4.7 M $\Omega$ 1 watt (yellow-violet-green)
	3-1-2	1	.82 $\Omega$ wire-wound 2 watt (gray-red-silver) (same size as 1 watt), 5%
3	3-25-5	1	1 $\Omega$ wire-wound, 5 watt, 1%
	3-22-5	1	3600 $\Omega$ wire-wound, 5 watt, 1%
4	5-2-7	8	30 k $\Omega$ film, 7 watt

KEY PART No.	PART No.	PARTS Per Kit	DESCRIPTION
<b>CAPACITORS</b>			
<b>Molded Mica</b>			
5	20-3	6	200 pF (red-black-brown)
6	20-123	1	500 pF (.0005 $\mu$ F)
<b>Mica</b>			
7	20-99	2	22 pF
	20-124	2	115 pF
	20-103	1	150 pF
	20-105	1	180 pF
	20-120	1	220 pF
	20-116	2	400 pF
	20-113	2	470 pF
	20-107	2	680 pF
<b>Disc</b>			
8	21-79	1	.001 $\mu$ F 6 kV
9	21-140	2	.001 $\mu$ F 500 volt
	21-70	3	.01 $\mu$ F 1.4 kV
	21-31	12	.02 $\mu$ F 500 volt



KEY PART No.	PARTS No.	PARTS Per Kit	DESCRIPTION	KEY PART No.	PARTS No.	PARTS Per Kit	DESCRIPTION	
<b>Other Capacitors</b>				<b>INSULATORS-GROMMETS-TERMINAL STRIPS-CONNECTORS</b>				
10	21-28	1	10 pF (10 MMF or 10 $\mu\mu\text{F}$ ) tubular ceramic	38	71 2	1	Ceramic feedthrough insulator (disassembled in bag)	
11	21-165	2	.001 $\mu\text{F}$ (1000 MMFD) 6 kV, ceramic	39	73 4	1	5/16" grommet	
12	25-19	1	20 $\mu\text{F}$ (MFD) electrolytic		73 3	4	1/2" grommet	
13	25-224	8	200 $\mu\text{F}$ (MFD) electrolytic		73 2	1	3/4" grommet	
14	26-145	1	840 pF variable	40	75 123	1	Line cord strain relief	
15	26-131	1	250 pF variable		75 124	1	6" x 4-1/2" fish paper insulator	
<b>CONTROLS-SWITCHES</b>					41	75 125	8	Capacitor mounting insulator
16	10-12	1	100 k $\Omega$ control	42	75-39	1	6-32 x 1-1/4" tapped phenolic spacer	
17	61-14	1	DPST rocker switch	43	75-42	3	6-32 x 3/4" tapped phenolic spacer	
18	61-15	1	DPDT rocker switch	44	431-14	1	2-lug terminal strip	
19	63-47	1	3-position rotary switch	45	431-10	3	3-lug terminal strip	
20	63-561	1	5-position rotary switch	46	431-42	1	5-lug terminal strip	
21	63-562	1	Rotary switch wafer	47	431-20	1	6-lug terminal strip	
22	65-28	2	Circuit breaker	48	431-13	1	4-screw terminal strip	
23	69-55	1	TPDT 110 VDC relay	49	432-137	6	Connector tab	
<b>COILS-CHOKES-TRANSFORMERS</b>				50	434-42	2	Phono socket	
24	40-1666	1	80/20 plate coil	51	434-93	2	5-lug ceramic tube socket	
25	40-964	2	10/15-meter input coil	52	436-5	2	Coaxial jack	
	40-965	1	20-meter input coil	53	438-9	2	Coaxial plug	
	40-966	1	40-meter input coil	54	438-12	1	Coaxial plug insert	
	40-1012	1	80-meter input coil	<b>WIRE-CABLE-SLEEVING</b>				
26	40-968	1	15/10 plate coil	89-40		1	Line cord	
27	45-53	2	Parasitic choke	134-36		2	Phono cable assembly	
28	45-4	3	1 mH RF choke	340-1		1	Small bare wire	
29	45-6	1	8.5 $\mu\text{H}$ RF choke	340-4		1	Large bare wire	
30	45-78	1	9 $\mu\text{H}$ RF choke	343-2		1	Coaxial cable, RG-58A/U	
31	45-61	1	50 $\mu\text{H}$ RF choke	343-8		1	Coaxial cable, RG-8/U	
32	54-237	1	High voltage transformer	344-2		1	Small black stranded wire	
	54-238	1	Filament and bias transformer	344-7		1	Large black stranded wire	
<b>DIODES-TUBES</b>				344-13		1	Blue hookup wire (thick insulation)	
33	56-24	1	1N458 silicon diode (yellow-green-gray)	344-50		1	Black hookup wire	
34	56-26	1	1N191 germanium diode (brown-white-brown)	344-51		1	Brown hookup wire	
35	56-82	1	1N3996A zener diode, 5.1V, 10 watt, w/mounting hardware	344-52		1	Red hookup wire	
36	57-27	15	Silicon diode	344-53		1	Orange hookup wire	
37	411-245	2	3-500Z tube	344-54		1	Yellow hookup wire	
				344-55		1	Green hookup wire	
				344-56		1	Blue hookup wire	
				345-1		1	Large metal braid	
				345-2		1	Small metal braid	
				346-4		1	Black sleeving	
				346-7		2	Clear sleeving (large)	
				346-29		1	Clear sleeving (small)	
				55	354-5	6	Cable tie	

KEY PART No.	PARTS No.	PARTS Per Kit	DESCRIPTION	KEY PART No.	PARTS No.	PARTS Per Kit	DESCRIPTION
<b>HARDWARE</b>				<b>Other Hardware (cont'd.)</b>			
<b>#6 Hardware</b>				97	258-115	1	Brass spring 5/8" x 3-1/2"
56	250-138	9	6-32 x 3/16" screw	98	259-10	1	Control solder lug
57	250-56	31	6-32 x 1/4" binder head screw	99	259-24	1	Long solder lug
58	250-416	1	6-32 x 1/4" flat head screw	100	260-12	2	Plate connector
59	250-8	29	#6 x 3/8" sheet metal screw	101	456-16	1	Shaft coupler
60	250-32	18	6-32 x 3/8" flat head screw	<b>METAL PARTS</b>			
61	250-89	15	6-32 x 3/8" binder head screw	102	90-464	1	Cabinet
62	250-218	4	6-32 x 3/8" phillips head screw	103	200-1251	1	Chassis
63	250-206	13	6-32 x 11/16" screw	104	100-1022	1	Capacitor bank bracket
64	250-40	4	6-32 x 1-1/2" screw	105	203-643	1	Front panel
65	250-47	1	6-32 x 2" screw	106	203-644	1	Rear panel
66	252-3	63	6-32 nut	107	203-646	1	Left side panel
67	253-1	17	#6 fiber flat washer	108	203-645	1	Right side panel
68	253-2	2	#6 fiber shoulder washer	109	204-1041	2	Angle bracket
69	253-96	4	#6 flat metal washer	110	204-2102	1	Plate coil bracket
70	254-1	64	#6 lockwasher	111	205-723	1	Top rear plate cover
71	255-77	2	7/16" spacer	112	205-724	1	Perforated top cover
72	255-71	4	6-32 x 3/4" tapped metal spacer	113	205-874	1	Perforated fan cover
73	255-21	3	6-32 x 7/8" tapped spacer	114	206-493	1	RF shield
74	259-1	19	#6 solder lug	115	206-457	1	Coil mounting shield
<b>#8 Hardware</b>				<b>MISCELLANEOUS</b>			
75	250-43	8	8-32 x 1/4" setscrew		85-344-1	1	Printed circuit board
76	250-137	8	8-32 x 3/8" screw	116	255-59	2	Black tapered spacer
77	252-4	8	8-32 nut	117	261-9	4	Rubber foot
78	254-2	8	#8 lockwasher		266-296	1	Fan blade
79	255-66	1	8-32 x 1-3/8" spacer	118	352-13	1	Silicone grease
80	259-2	1	#8 solder lug	119	407-145	1	Plate amperes meter
<b>#10 Hardware</b>					407-146	1	Multi-meter
81	250-331	1	10-32 x 1" screw		420-601	1	Fan motor
82	252-5	2	10-32 nut	120	453-135	1	Phenolic shaft
83	252-163	1	10-32 wing nut	121	462-191	2	Small knob
84	254-3	2	#10 lockwasher	122	462-210	3	Large knob
<b>Other Hardware</b>					390-147	1	Danger high voltage label
85	207-8	2	Cable clamp	123	391-64	1	Nameplate
86	250-213	8	4-40 x 5/16" screw		391-34	1	Blue and white label
87	252-15	8	4-40 nut	124	432-199	1	Wire nut
88	252-7	3	Control nut		490-5	1	Nut starter
89	252-10	2	Speednut		597-260	1	Parts Order Form
90	253-10	3	Control flat washer		597-308	1	Kit Builders Guide
91	253-42	14	1/2" flat washer			1	Manual (See front cover for part number.)
92	253-19	2	3/4" flat washer	<b>Solder</b>			
93	254-4	2	Control lockwasher				
94	254-9	16	#5 lockwasher				
95	259-25	1	#10 double lug				
96	259-16	1	#10 solder lug				



# STEP-BY-STEP ASSEMBLY

Before starting to assemble this kit, read the "Kit Builders Guide" for complete information on wiring, soldering, and step-by-step assembly procedures.

The illustrations in this section of the Manual are called Pictorials and Details. Pictorials show the overall operation for a group of assembly steps; Details are used in addition to the Pictorials to illustrate a single step. When you are directed to refer to a certain Pictorial "for the following steps," continue using that Pictorial until you are referred to another Pictorial for another group of steps.

As the drawings in the Manual may be slightly distorted to show all the parts clearly, look at the Chassis Photos (Pages

86 through 89) from time to time to see the actual positions of wires and components.

Lockwashers and nuts will be used with most screws when mounting parts, unless the assembly steps state otherwise. Consequently, the applicable steps will call out only the size and type of hardware used. For example, the phrase "Use 6-32 x 1/4" hardware" means to use 6-32 x 1/4" screws, one or more #6 lockwashers, and 6-32 nuts. Refer to the Details for the proper installation of hardware. Be sure to position each part as shown in the Pictorials. Follow the instructions carefully, and read the entire step before performing the operation.

When a step directs you to "connect" an insulated wire, first prepare its ends by removing 1/4" of insulation.

## CIRCUIT BOARD

Solder a part or group of parts only when directed. Use 1/2 watt resistors unless directed otherwise in a step. Each resistor will be called out by the resistance value (in  $\Omega$ ,  $k\Omega$ , or  $M\Omega$ ) and color code. Capacitors will be called out by the capacitance value and type.

On the circuit board, be especially careful not to cover unused holes with solder or bridge solder across foils during assembly. Perform the steps in Pictorial 1-1.

**START**



FOR GOOD SOLDERED CONNECTIONS, YOU MUST KEEP THE SOLDERING IRON TIP CLEAN. WIPE IT OFTEN WITH A DAMP SPONGE OR CLOTH.

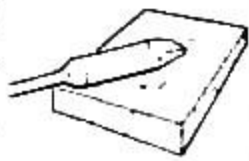

NOTE: DIODES MAY BE SUPPLIED IN ANY OF THE FOLLOWING SHAPES. THE CATHODE END OF THE DIODE IS MARKED WITH A BAND OR BANDS. ALWAYS POSITION THIS END AS SHOWN IN THE PICTORIAL.

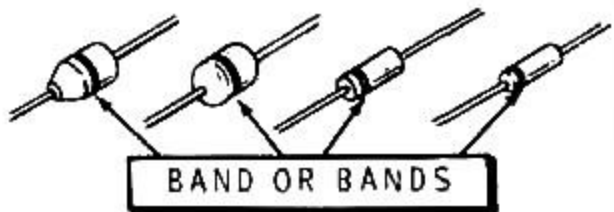

( ) Position the circuit board as shown and install diodes (#57-27) at D7, D5, D3, D1, D9, D11, and D13. Make sure all seven cathode banded ends are to the right.

( ) Solder all leads to the foil and cut off the excess lead lengths.

( ) Install diodes (#57-27) at D6, D4, D2, D8, D10, D12, and D14 with their cathode ends to the left.

( ) Solder all leads to the foil and cut off the excess lead lengths.

( ) CAREFULLY INSPECT ALL DIODES IN THE PRECEDING STEPS TO BE SURE THEY ARE POSITIONED AS SHOWN IN THE PICTORIAL AND ON THE CIRCUIT BOARD.

**CONTINUE**

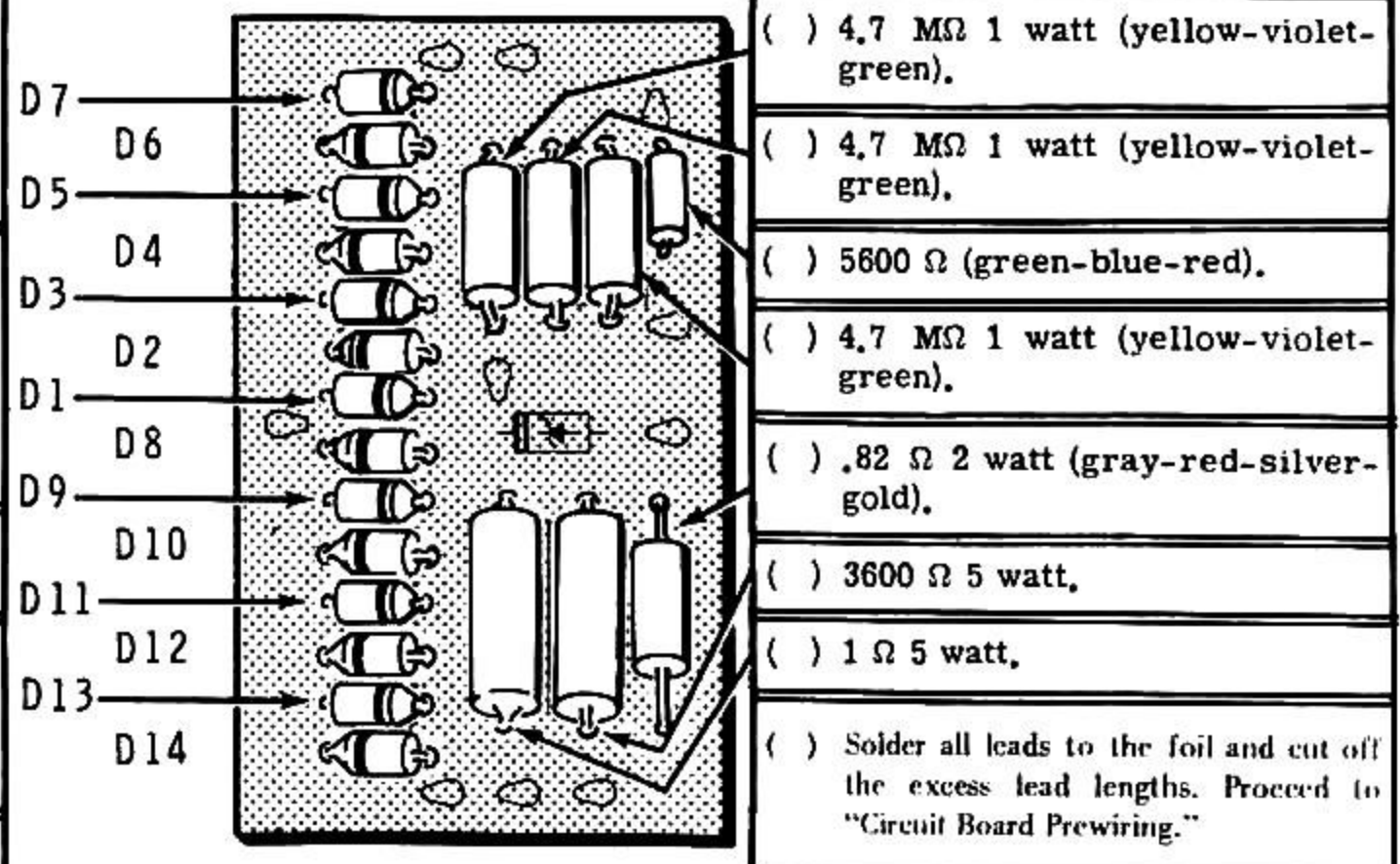

PICTORIAL 1-1

**CIRCUIT BOARD PREWIRING**

**NOTE:** To prepare lengths of hookup wire, as in the following step, cut the wire to the indicated length and remove 1/4" of insulation from each end. If the wire is stranded, twist the ends tightly and apply a small amount of solder to hold the strands together. Unless otherwise stated, "hookup wire" will mean the small solid-conductor wire supplied in various colors.

( ) Prepare the following lengths of hookup wire:

5-1/4" red

3-3/4" black

6-1/2" black

17-1/2" small black stranded wire

7-1/2" orange

6-1/2" yellow

9-1/2" heavy blue (thick insulation)

2-3/4" heavy blue (thick insulation)

Refer to Pictorial 1-2 for the following steps.

From the component side of the circuit board, insert one end of each of the following wires into the designated hole. Solder each wire on the foil side.

- ( ) Connect a 5-1/4" length of red hookup wire to hole A in the circuit board (S-1).
- ( ) Connect a 3-3/4" length of black hookup wire to hole B on the circuit board (S-1).
- ( ) Connect a 6-1/2" length of black hookup wire to hole C on the circuit board (S-1).
- ( ) Connect a 17-1/2" length of black stranded wire to hole E on the circuit board (S-1).
- ( ) Connect a 7-1/2" length of orange hookup wire to hole G on the circuit board (S-1).
- ( ) Connect a 6-1/2" length of yellow hookup wire to hole F on the circuit board (S-1).
- ( ) Connect a 9-1/2" length of heavy blue hookup wire to hole H on the circuit board (S-1).
- ( ) Connect a 2-3/4" length of heavy blue hookup wire to hole J on the circuit board (S-1).
- ( ) Trim all excess lead lengths from the foil side of the circuit board.

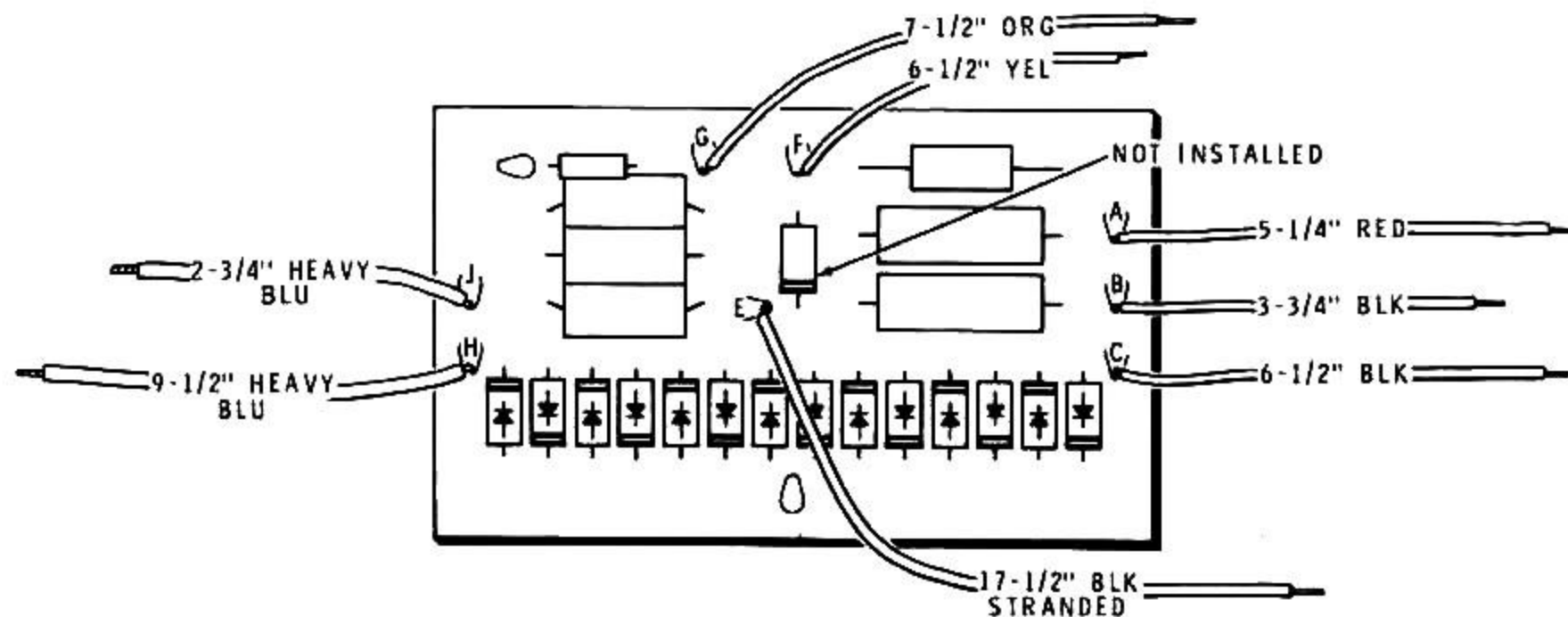

**PICTORIAL 1-2**



- ( ) Carefully inspect the foil side of the circuit board; all lettered holes except D and K should be soldered. Make sure there are no solder bridges between foils. Also note that one diode is not installed.

This completes the prewiring of the circuit board. Set it aside until called for later. Proceed with the "Input Coil Assembly" section.

## INPUT COIL ASSEMBLY

Refer to Pictorial 2-1 for the following steps.

Refer to Detail 2-1A for the next two steps.

**NOTE:** A plastic nut starter has been provided with this kit. Use it to hold and start nuts on screws. See Page 3 of the "Kit Builders Guide" for more information.

- ( ) Install three #6 solder lugs on the coil mounting shield (#206-457) at CL with 6-32 x 3/8" hardware. Position the lugs as shown in Detail 2-1B.
- ( ) Install a #6 solder lug at DF with a 6-32 x 1/4" screw and a 6-32 nut. Form the solder lug as shown.

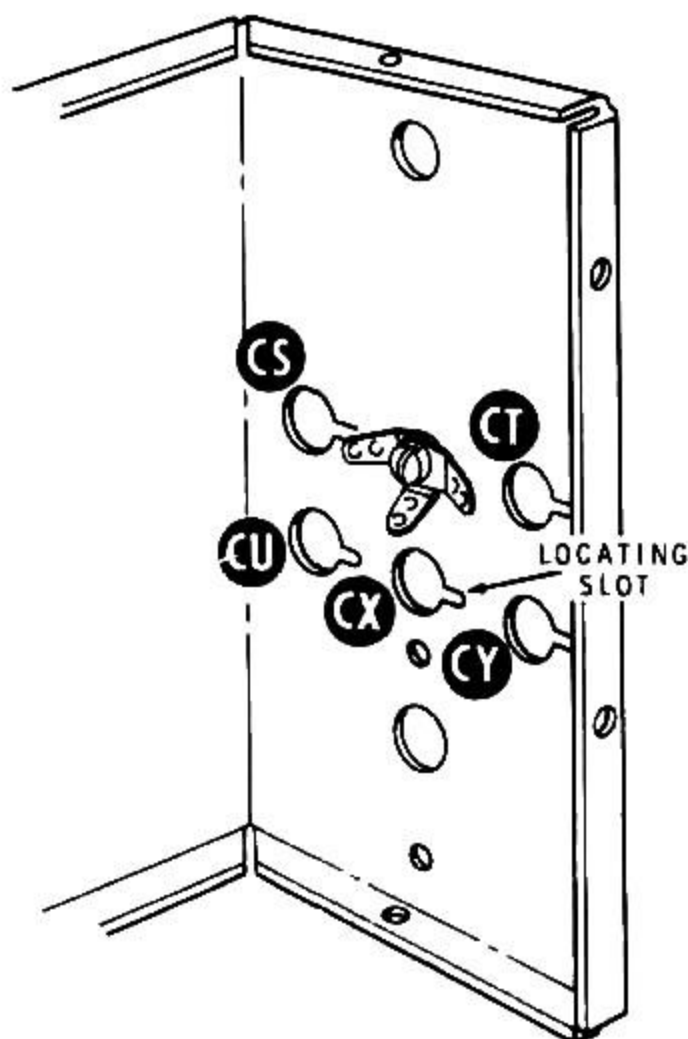

**Detail 2-1B**

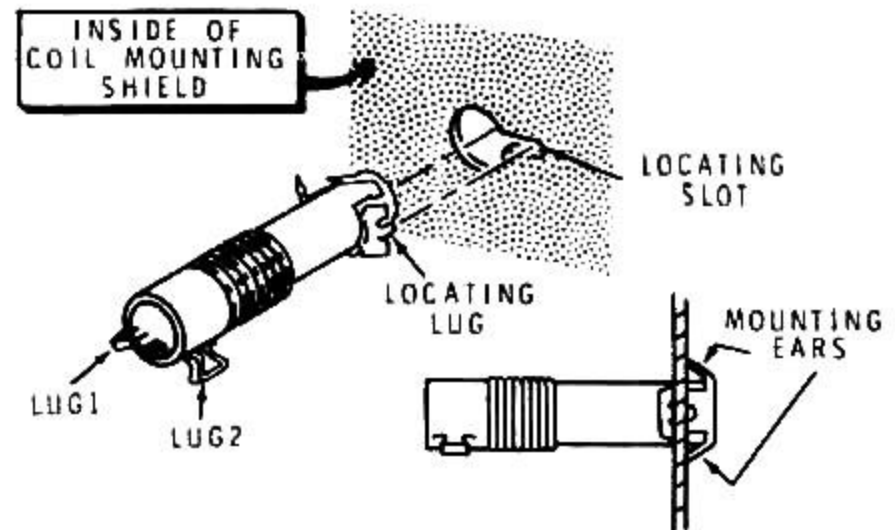

**Detail 2-1C**

Detail 2-1B shows the coil mounting locations for the following steps. Note that the locating lug of each coil must be positioned in the locating slot, and that each coil must be pushed into its mounting hole until the mounting ears snap out to hold the coil in place as shown in Detail 2-1C.

- ( ) Install the 20-meter coil (#40-965) at CU. See Detail 2-1C.
- ( ) Install a 10/15-meter coil (#40-964) at CX.
- ( ) Install a 10/15-meter coil (#40-964) at CY.
- ( ) Install the 80-meter coil (#40-1012) at CS.
- ( ) Install the 40-meter coil (#40-966) at CT.

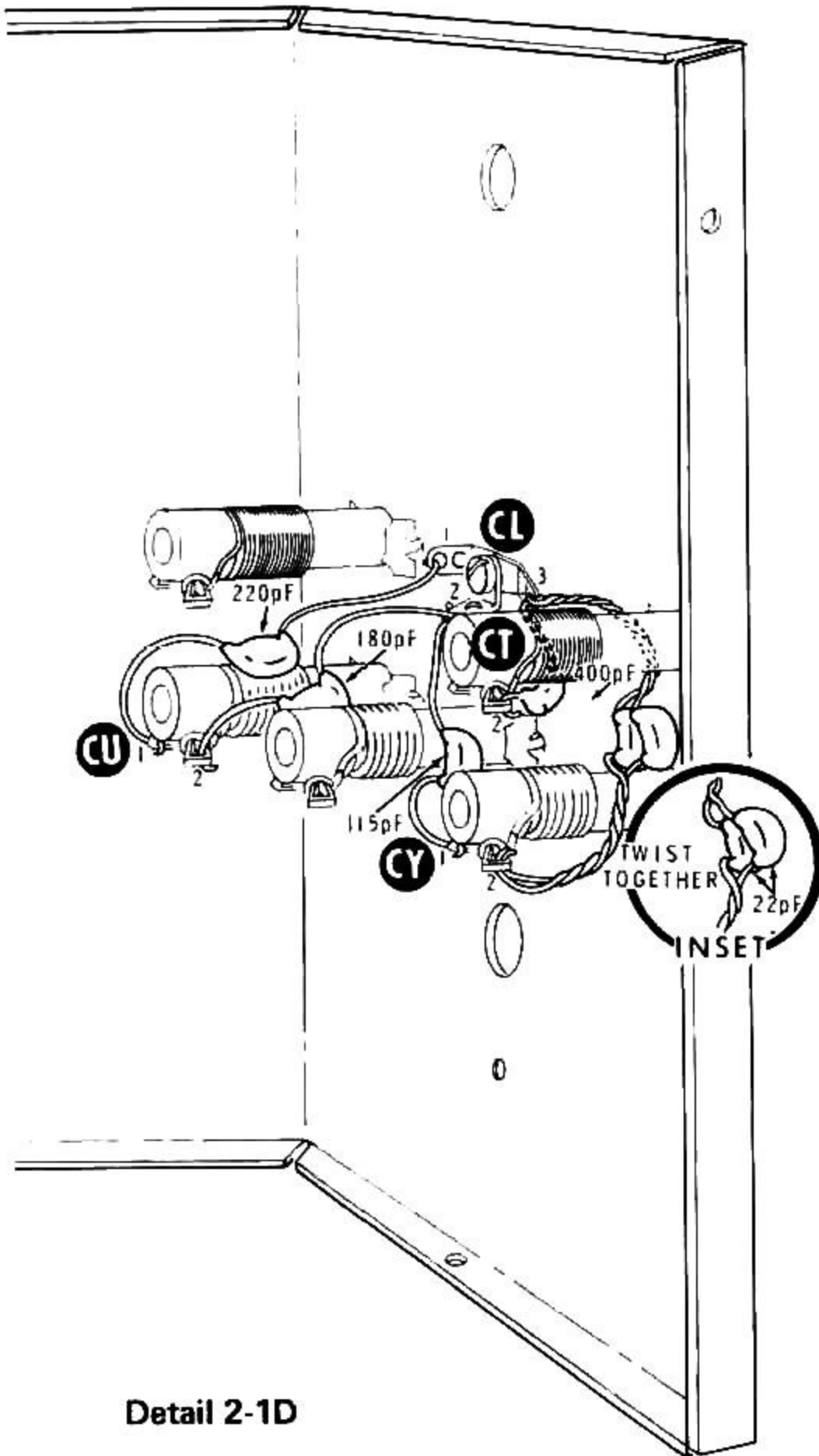

Detail 2-1D

Refer to Detail 2-1D for the following steps.

**NOTE:** When you wire capacitors to the five coils in the following steps, position the body of each capacitor against its coil. However, be sure the capacitor leads do not touch the wire of the coil.

Note the positions of lugs 1 and 2 of each coil as shown in Detail 2-1C, on Page 13.

- ( ) Connect a 220 pF mica capacitor from lug 1 of coil CU (NS) to ground lug CL-1 (NS). Position the capacitor close to the coil as shown.

- ( ) Connect a 180 pF mica capacitor from lug 2 of coil CU (NS) to ground lug CL-2 (NS).
- ( ) Connect a 400 pF mica capacitor from lug 2 of coil CT (NS) to ground lug CL-3 (NS).
- ( ) Connect a 115 pF mica capacitor from lug 1 of coil CY (NS) to ground lug CL-2 (NS).
- ( ) Refer to the inset drawing on Detail 2-1D and twist together the leads of two 22 pF mica capacitors as shown. **NOTE:** Each twisted pair of leads will be counted as two leads in a solder step.
- ( ) Connect one pair of leads to lug 2 of coil CY (NS) and the other pair of leads to ground lug CL-3 (NS).

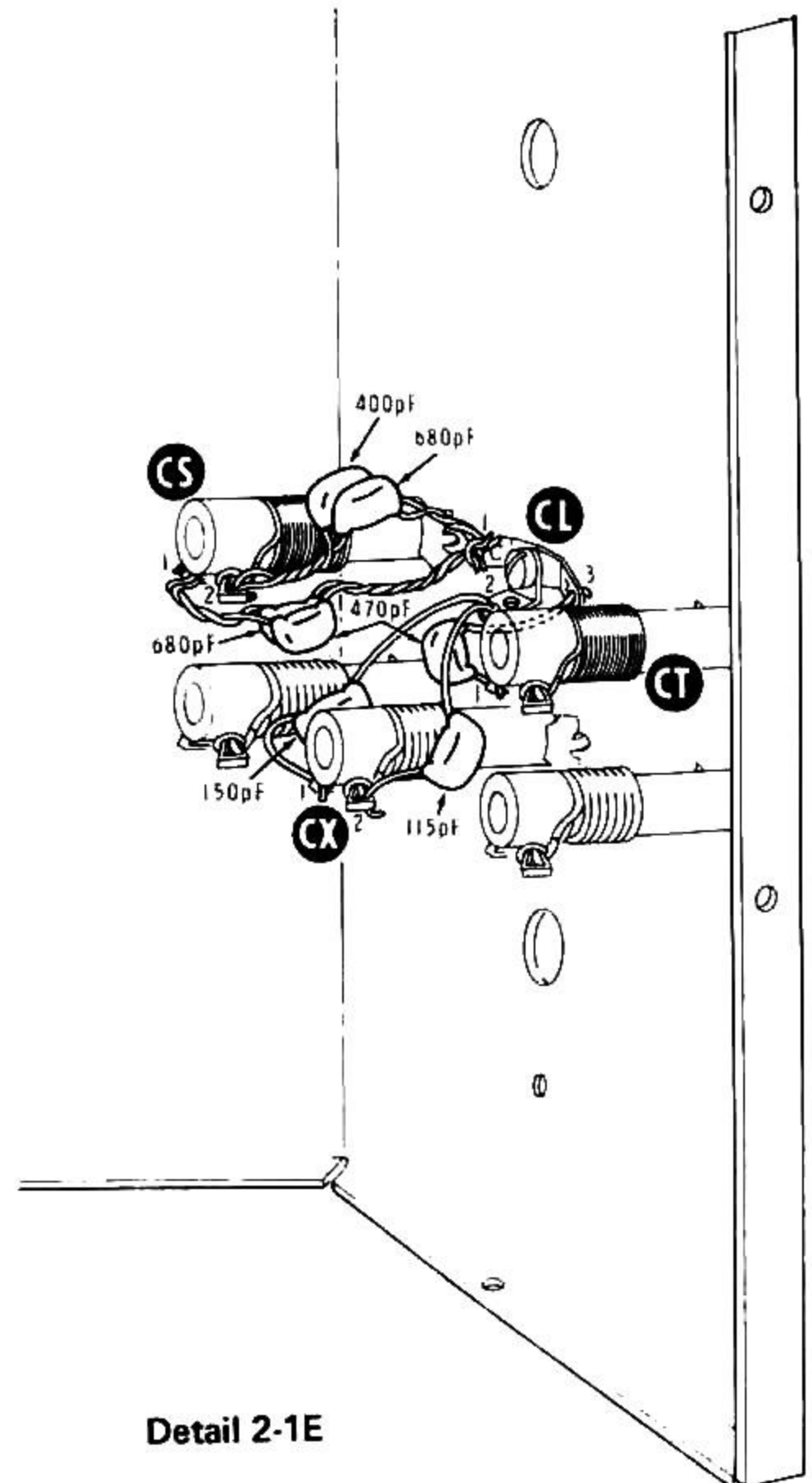

Detail 2-1E

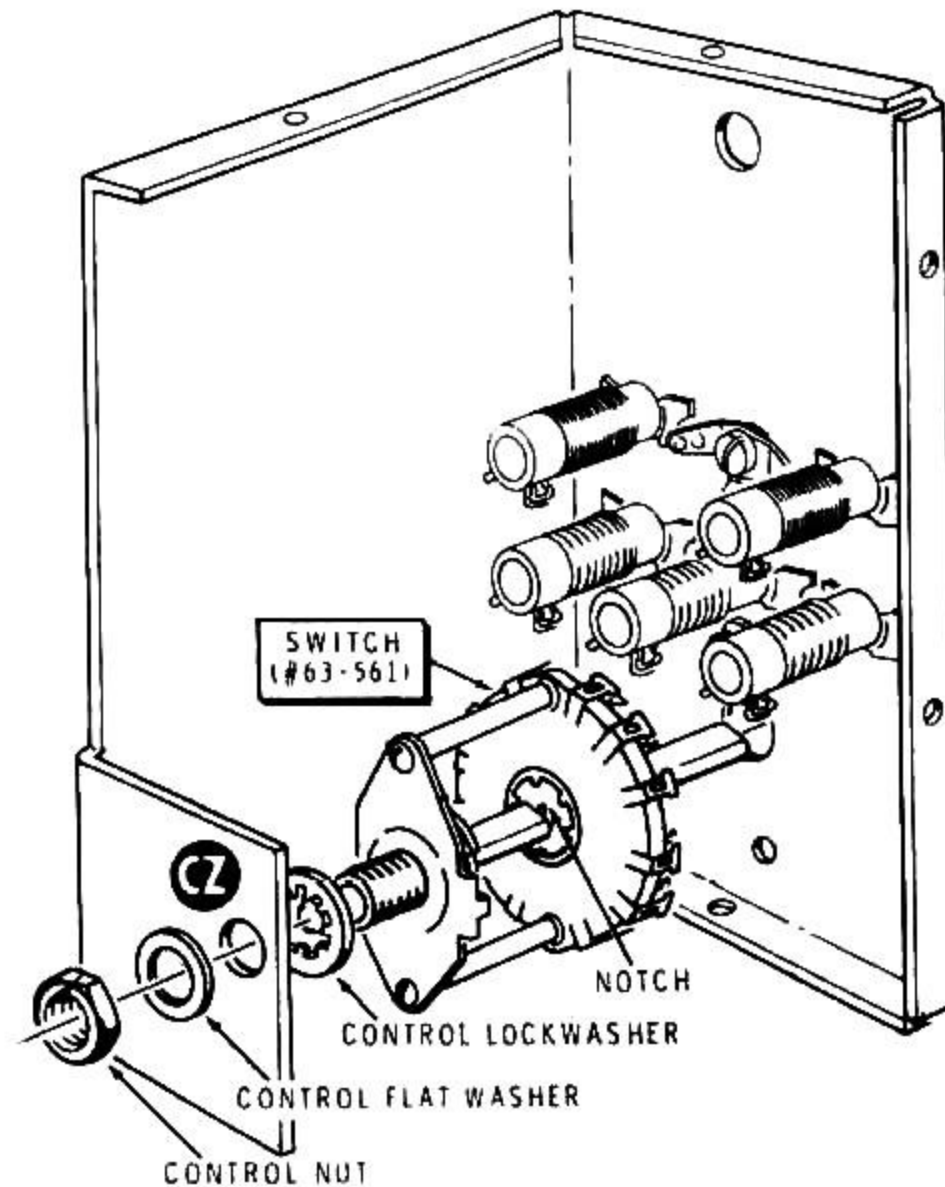

Detail 2-1F

Refer to Detail 2-1E for the following steps.

- ( ) Connect a 150 pF mica capacitor from lug 1 of coil CX (NS) to ground lug CL-2 (NS). Position the capacitor as shown.
- ( ) Connect a 115 pF mica capacitor from lug 2 of coil CX (NS) to ground lug CL-2 (S-4).
- ( ) Twist the leads of a 470 pF and a 680 pF mica capacitor together as in a previous step. Connect one pair of leads to lug 1 of coil CS (NS) and the other pair of leads to ground lug CL-1 (NS). Position the capacitors as shown.
- ( ) Twist the leads of a 400 pF and a 680 pF mica capacitor together. Connect one pair of leads to lug 2 of coil CS (NS) and the other pair of leads to ground lug CL-1 (S-5).
- ( ) Connect a 470 pF mica capacitor from lug 1 of coil CT (NS) to ground lug CL-3 (S-4). Position the capacitor as shown.
- ( ) Turn the shaft of the 5-position rotary switch (#63-561) fully clockwise as viewed from the shaft end.
- ( ) Refer to Detail 2-1F and mount the 5-position rotary switch on the coil mounting shield at CZ. Use a control nut, a control lockwasher, and a control flat washer. Be sure the two switch spacers and the switch shaft are aligned vertically and that the notch in the rotor is positioned as shown. Tighten the hardware only finger tight.

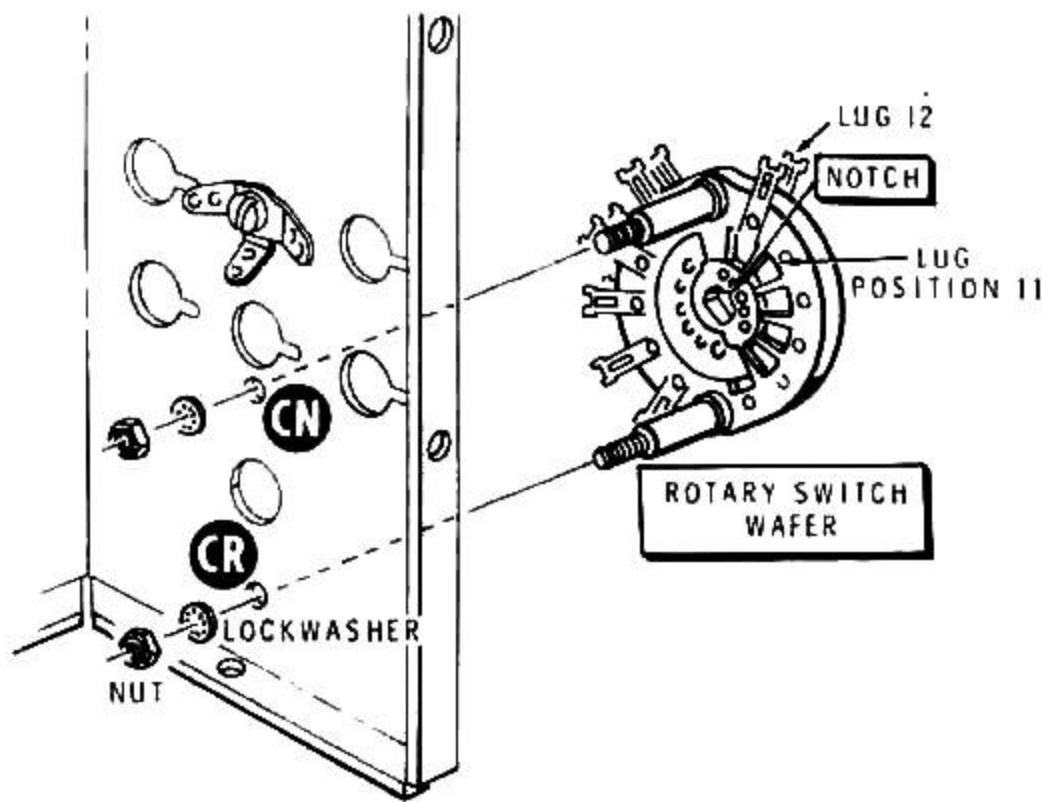

Detail 2-1G

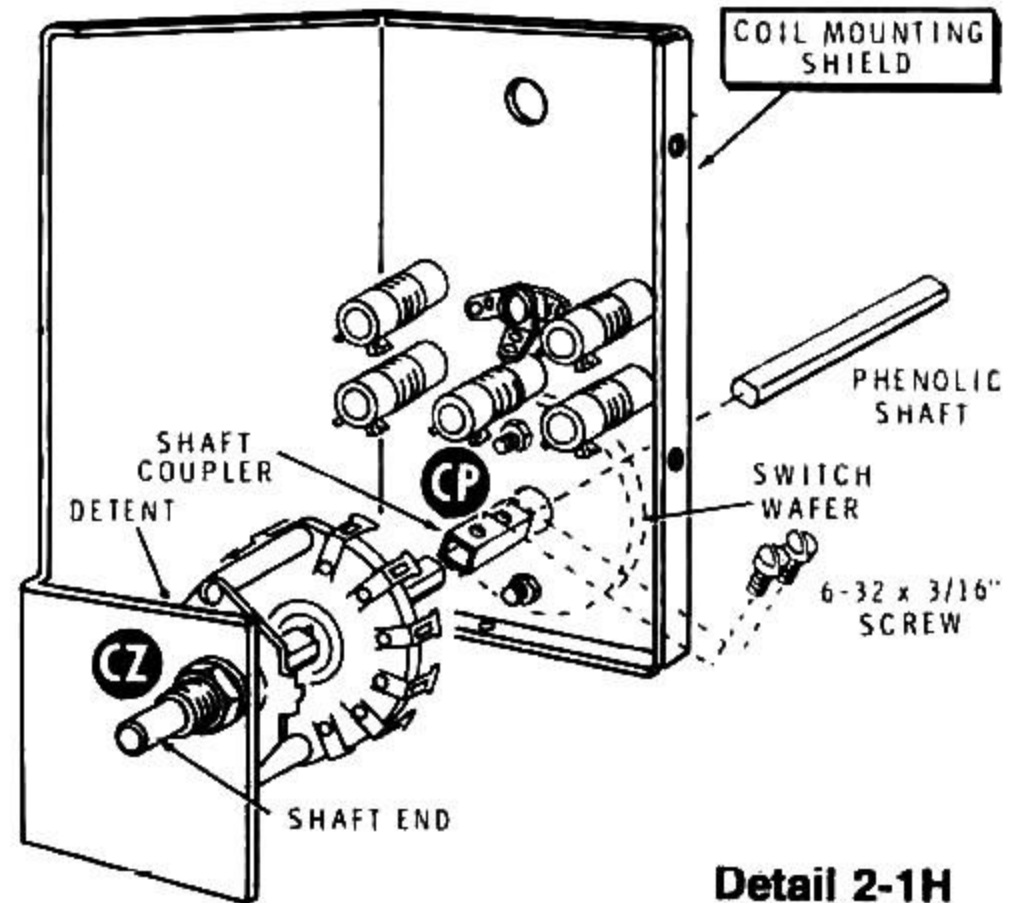

Detail 2-1H

- ( ) Refer to Detail 2-1G and remove the two nuts from the screws passing through the two spacers of the separate rotary switch wafer (#63-562). Retain the spacers on the screws.
- ( ) Insert the bared screw ends into holes CN and CR of the coil mounting shield with lug 12 positioned as shown. Secure the switch with two #6 lockwashers and with the two nuts previously removed.
- ( ) Position the rotating portion of the switch wafer as shown so the notch points between switch lugs 11 and 12. The phenolic shaft (#453-135) may be used to turn the switch rotor.
- ( ) Check to be sure that switch CZ is still turned fully clockwise (viewed from the shaft end).

Refer to Detail 2-1H for the following steps.

- ( ) Start two 6-32 x 3/16" screws into the tapped holes of the shaft coupler (#456-16). Then slide half the length of the shaft coupler onto the shaft of switch CZ and tighten one screw. The screws should be at the one o'clock position (viewed from the shaft end).

**CAUTION:** Be careful when you tighten the setscrew in the following step. Use an angle screwdriver if one is available.

- ( ) Slide the phenolic shaft (#453-135) through the switch wafer on the rear of the coil mounting shield, through hole CP in the shield, and into the shaft coupler. Tighten the remaining setscrew in the shaft coupler onto the phenolic shaft.
- ( ) Hold the 5-position rotary switch detent (at CZ) stationary and turn the shaft coupler fully counterclockwise.

Refer to Pictorial 2-1 and Detail 2-1H and Detail 2-1J for the next three steps.

- ( ) Note the metal rotor of switch wafer CP. Turn the switch detent at CZ slightly so the metal rotor of switch wafer CP is just even with the edge of lug 6 as shown. Then tighten the hardware on switch CZ.
- ( ) Check the metal rotor of switch wafer CP again. If the metal rotor extends past lug 6, arcing can occur between the rotor and lug 5.
- ( ) Turn the switch shaft through each of its five positions and check the metal rotor to make sure it makes contact with each lug in turn.

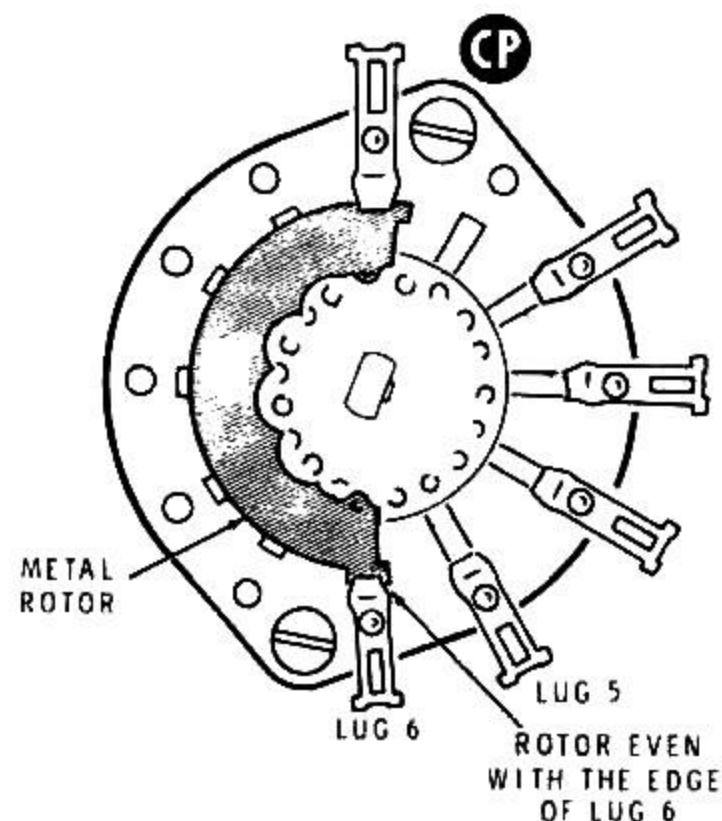

Detail 2-1J

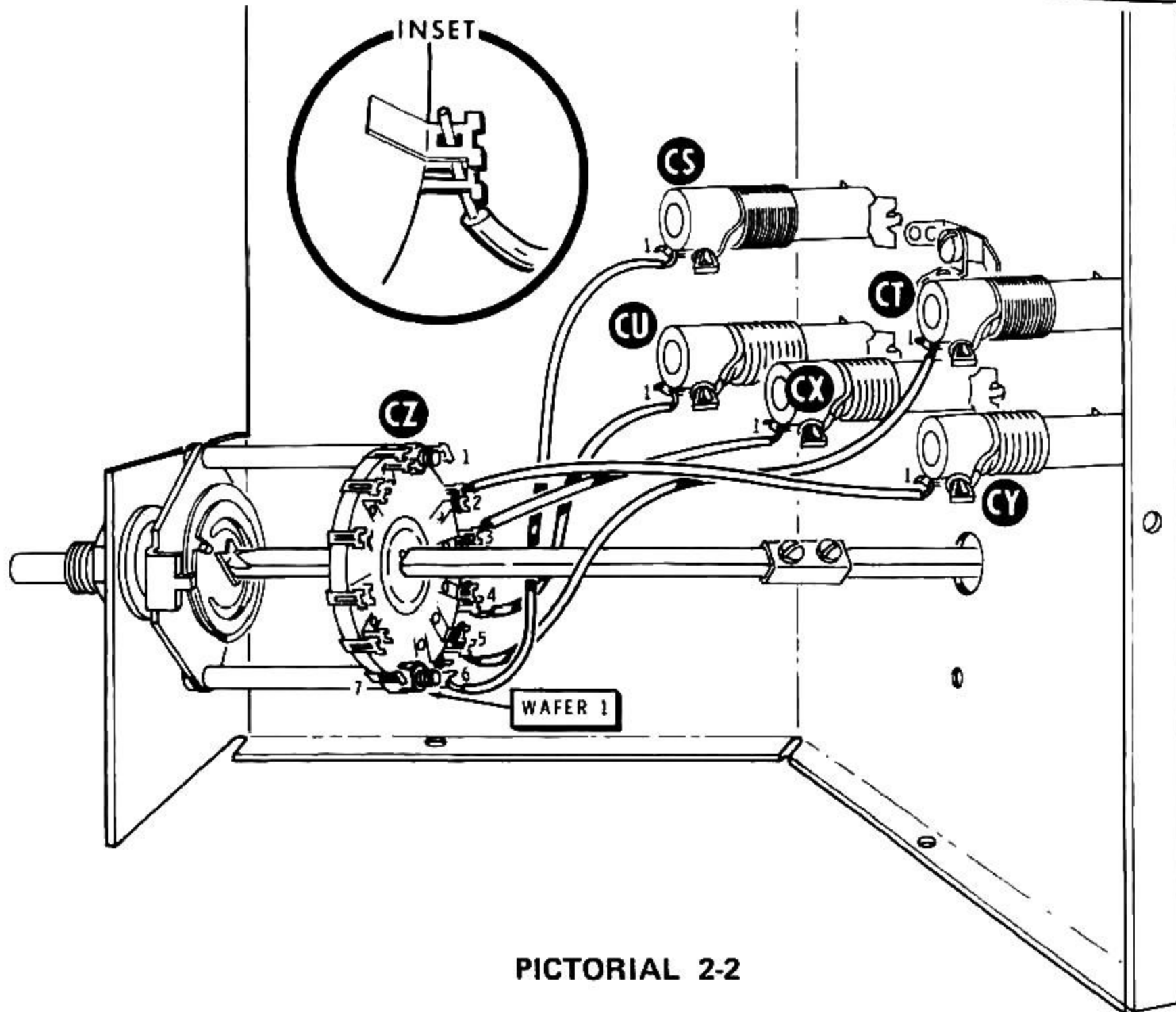

PICTORIAL 2-2

Refer to Pictorial 2-2 for the following steps.

( ) Prepare the following lengths of black hookup wire. The wires are listed in the order in which they will be used.

2-1/4"

3-1/2"

3-1/2"

1-3/4"

2"

NOTE: Switch CZ has lugs only on the front of the wafer at positions 1 and 7. All other positions on this wafer have lugs on the front and on the rear of the wafer. Be sure to connect the wire to both lugs when there are double lugs.

When a wire passes through a connection and then goes to another point, it will count as two wires in the solder instructions, one entering and one leaving the connection. Thus, when a wire passes through one switch lug and then goes on to the other switch lug at the same position, it will count as three wires (S-3) in the solder instructions.

Connect the prepared hookup wires from the coils to wafer 1 of switch CZ as follows:

Wire Length	Connect From Lug 1 of	Connect to Wafer 1 of Switch CZ
( ) 2-1/4"	Coil CU (S-2)	Lug 4 (S-3)
( ) 3-1/2"	Coil CT (S-2)	Lug 5 (S-3)
( ) 3-1/2"	Coil CS (S-3)	Lug 6 (S-3)
( ) 1-3/4"	Coil CX (S-2)	Lug 3 (S-3)
( ) 2"	Coil CY (S-2)	Lug 2 (S-3)



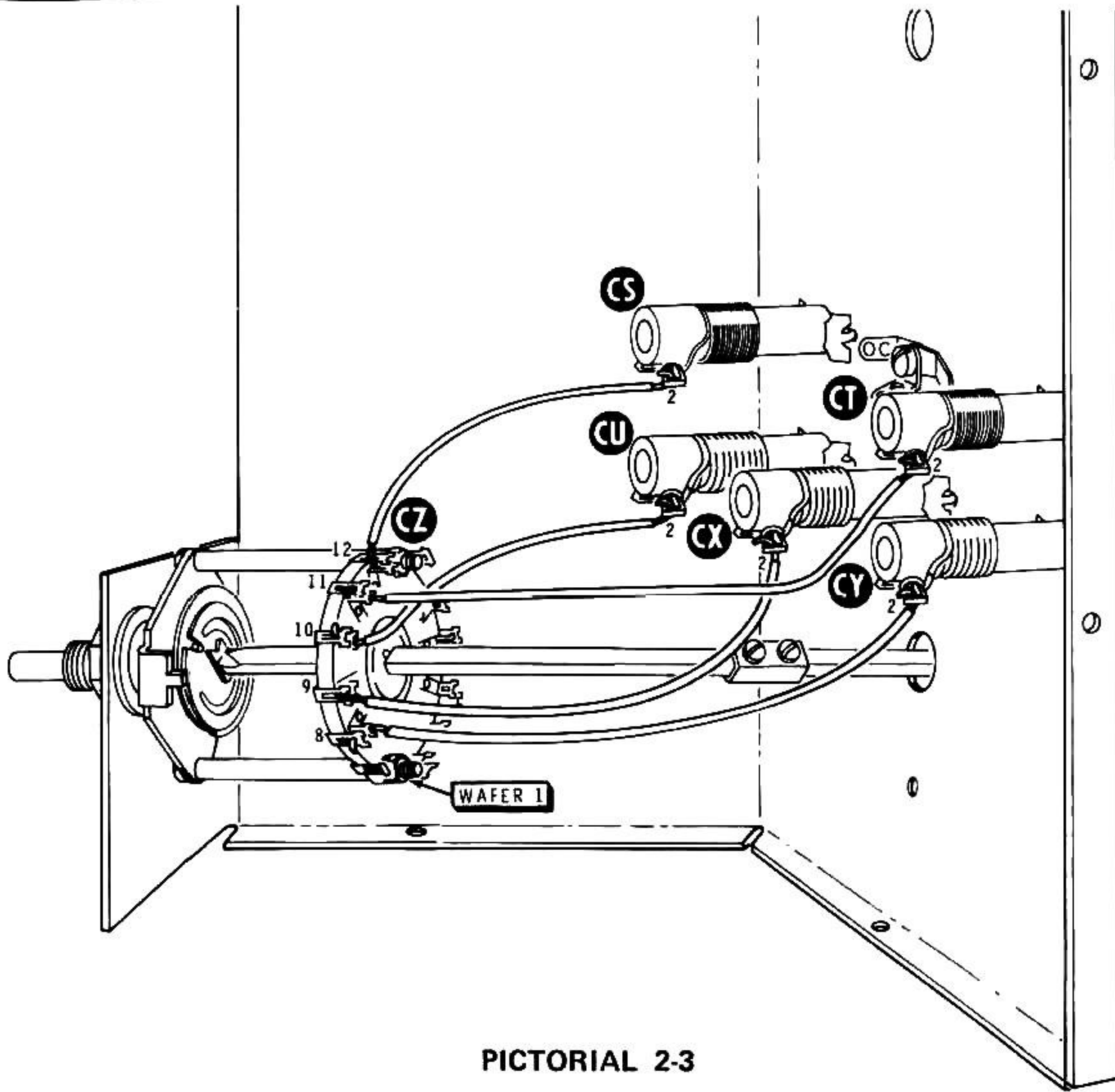

PICTORIAL 2-3

Refer to Pictorial 2-3 for the following steps.

Connect the prepared hookup wire from the coils to wafer 1 of switch CZ as follows:

( ) Prepare the following lengths of black hookup wire. Wires are listed in the order in which they will be used.

2-1/2"

2"

2-1/2"

2-1/2"

2-1/2"

Wire Length	Connect From Lug 2 of	Connect to Wafer 1 of Switch CZ
( ) 2-1/2"	Coil CY (S-3)	Lug 8 (S-3)
( ) 2"	Coil CX (S-2)	Lug 9 (S-3)
( ) 2-1/2"	Coil CU (S-2)	Lug 10 (S-3)
( ) 2-1/2"	Coil CT (S-2)	Lug 11 (S-3)
( ) 2-1/2"	Coil CS (S-3)	Lug 12 (S-3)

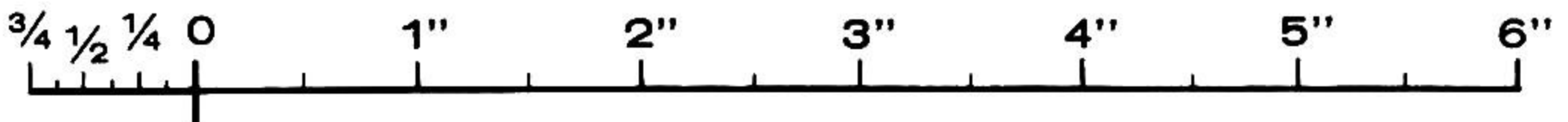

**PART A**

TAKING CARE NOT TO CUT THE OUTER SHIELD OF VERY THIN WIRES, REMOVE THE OUTER INSULATION.



PUSH BACK THE SHIELD. THEN MAKE AN OPENING IN THE SHIELD AND BEND OVER AS SHOWN. PICK OUT THE INNER LEAD.



REMOVE THE INNER INSULATION AND STRETCH OUT THE SHIELD. APPLY A SMALL AMOUNT OF SOLDER TO THE END OF THE SHIELD AND THE INNER LEAD. USE ONLY ENOUGH HEAT FOR THE SOLDER TO FLOW.

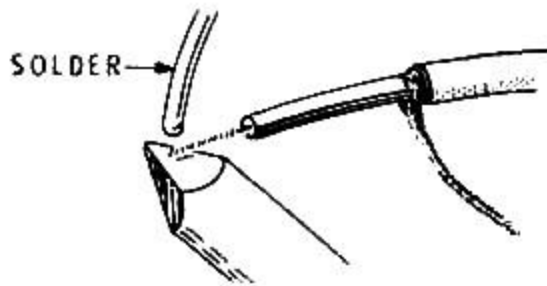

**PART B**

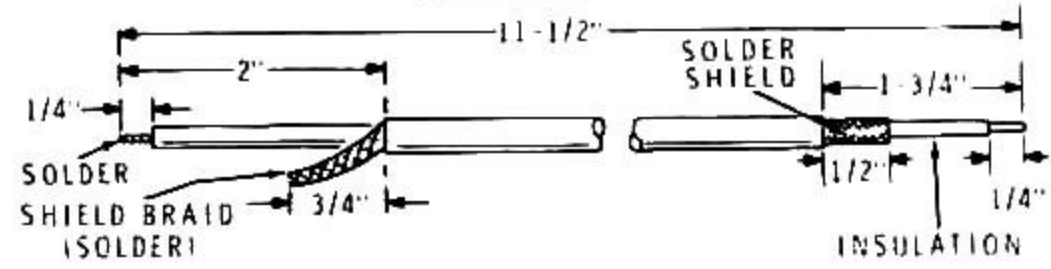

**PART C**

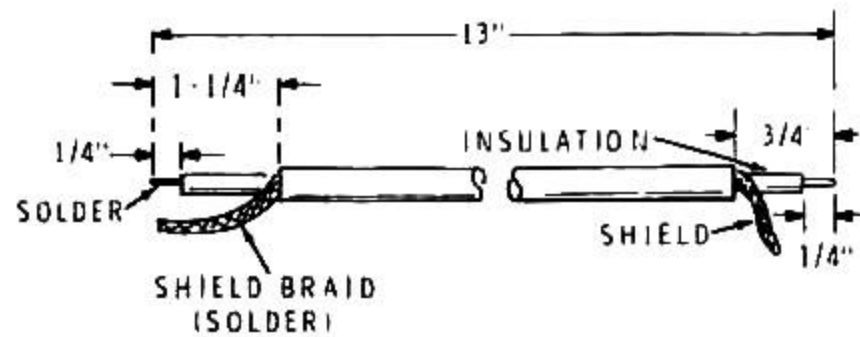

**PICTORIAL 2-4**

**NOTE:** When you prepare coaxial cables in the following steps, refer to Part A of Pictorial 2-4 for the method of removing the inside of the cable from the shield braid. Be careful not to melt the inner insulation.

solder to each end to hold the small strands together. In a like manner, twist and solder the end of the shield braid.

( ) Prepare an 11-1/2" length of RG-58A/U coaxial cable as shown in Pictorial 2-4, Part B. Twist the center conductor wires together and apply a small amount of

( ) Refer to Pictorial 2-4, Part C, and prepare a 13" length of RG-58A/U coaxial cable as shown.

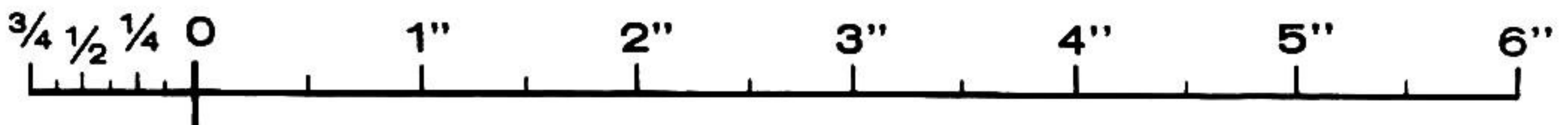

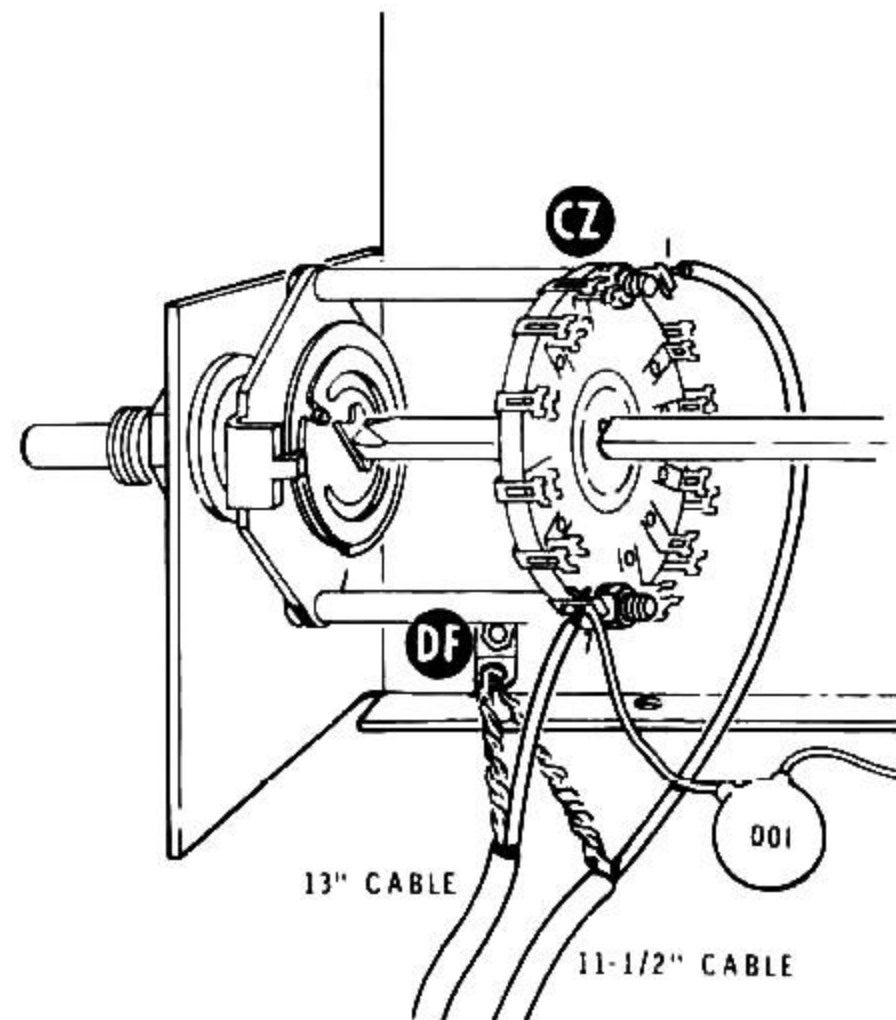

**PICTORIAL 2-5**

- ( ) Refer to Pictorial 2-5 and connect the 1-1/4" end of the center conductor of the 13" coaxial cable to lug 7 of wafer 1 of switch CZ (NS). Connect the shield braid to solder lug DF (NS).
- ( ) Connect the 2" end of the center conductor of the 11-1/2" coaxial cable to lug 1 of wafer 1 of switch CZ (S-1). Connect the braid to solder lug DF (S-2). NOTE: The other ends of the coaxial cables will be connected later.
- ( ) Turn the switch shaft to its stop in each direction and make sure that no wires interfere with the coupling.
- ( ) Cut each lead of a 500 volt (smaller) .001  $\mu$ F disc capacitor to a length of 3/4". Connect one lead of this capacitor to lug 7 of wafer 1 of switch CZ (S-2). The other lead will be connected later.

This completes the "Input Coil Assembly."

Set the input coil assembly aside until it is called for later.

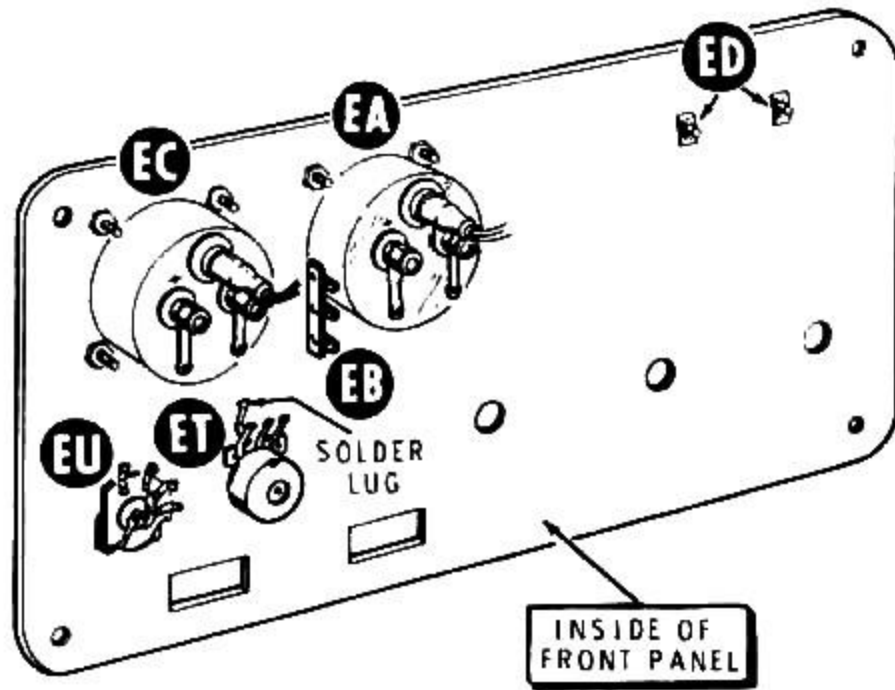

PICTORIAL 3-1

**FRONT PANEL**

NOTE: To avoid scratching the front panel and meter faces during the following steps, place a soft cloth on your work table.

Refer to Pictorial 3-1 for the following steps.

- ( ) Refer to Detail 3-1A and install the Heathkit nameplate in the two holes marked ED. Use the two speednuts.

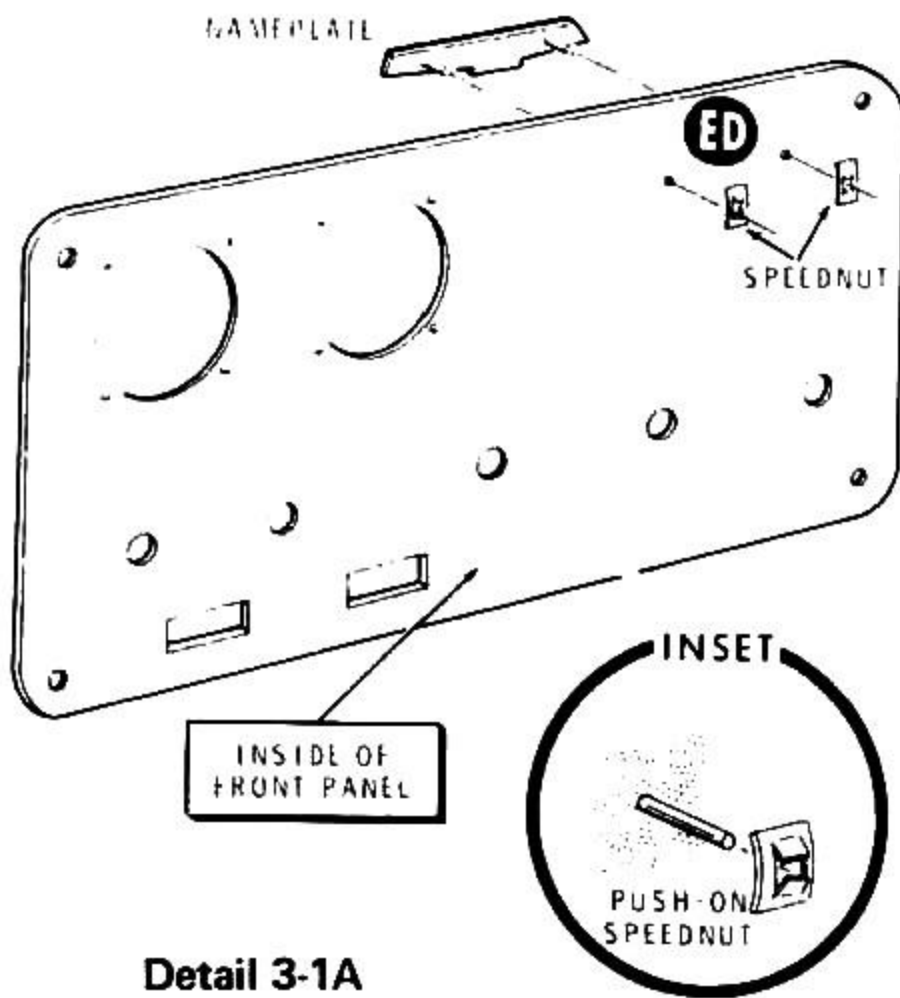

Detail 3-1A

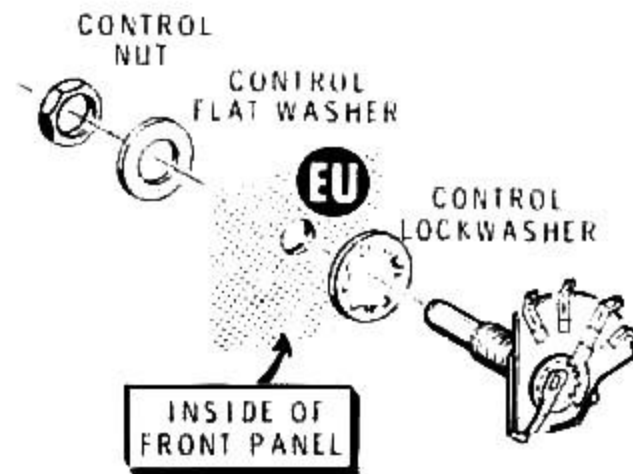

Detail 3-1B

- ( ) Refer to Detail 3-1B and install the 3-position rotary switch (#63-47) at EU. Use a control lockwasher, a control flat washer, and a control nut. Position the switch lugs as shown in the Pictorial.
- ( ) Refer to Detail 3-1C and install the 100 kΩ sensitivity control (#10-12) at ET. Use a control solder lug, a control flat washer, and a control nut. Form the control solder lug as shown. Then align the control solder lug with lug 1 of the control.

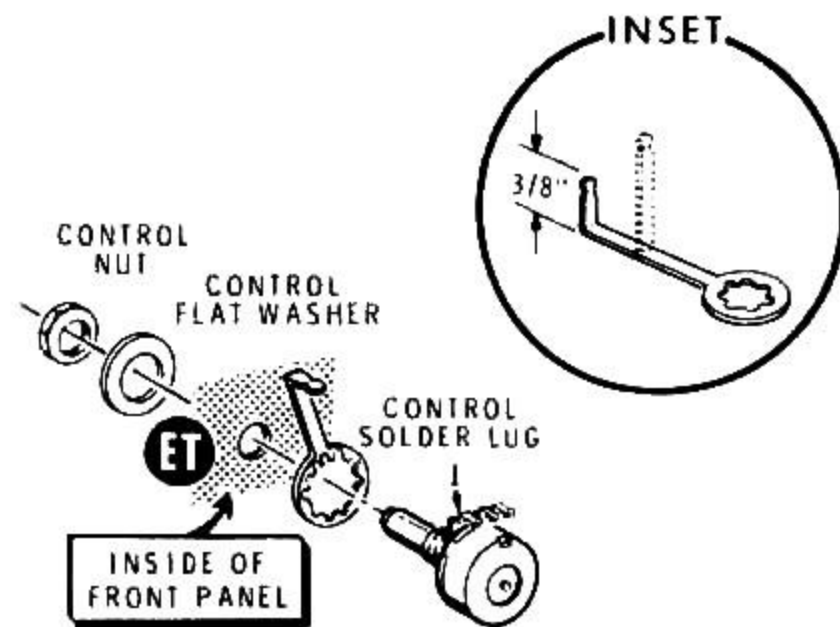

Detail 3-1C

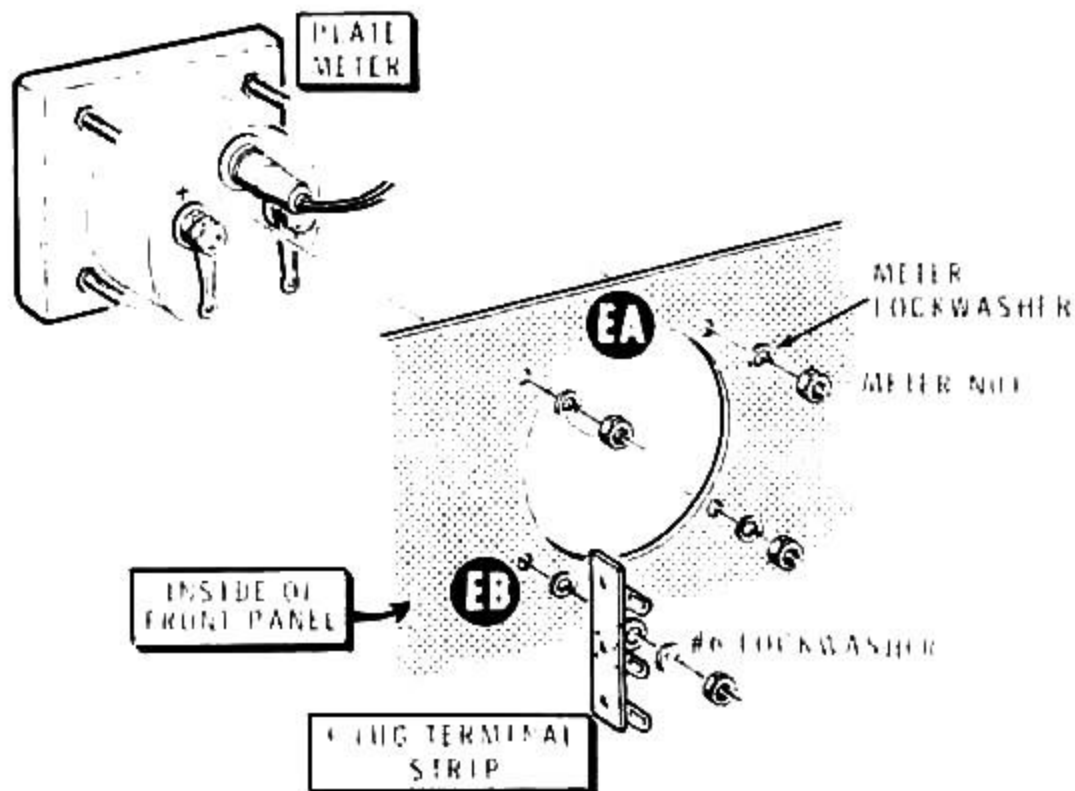

Detail 3-1D

NOTE: Before mounting the terminal strip in the following step, scrape away any paint around hole EB which would prevent the lockwasher and terminal strip foot from making good contact with the panel.

- ( ) Refer to Detail 3-1D and install the plate meter (#407-145) at EA. Use the hardware supplied with the meter. Install a 3-lug terminal strip at EB. Note the lockwashers used. CAUTION: Do not overtighten the meter hardware as the meter case can be damaged.
- ( ) Refer to Detail 3-1E and install the multi-meter (#407-146) at EC. Use the hardware supplied with the meter.
- ( ) Remove and discard the wire jumpers between the meter terminals on each meter.

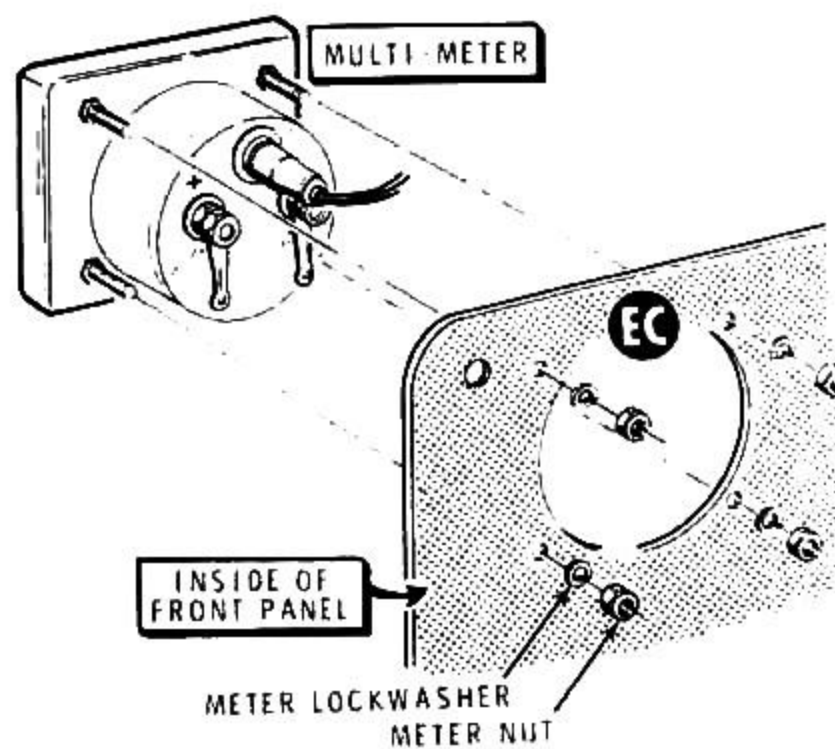

Detail 3-1E

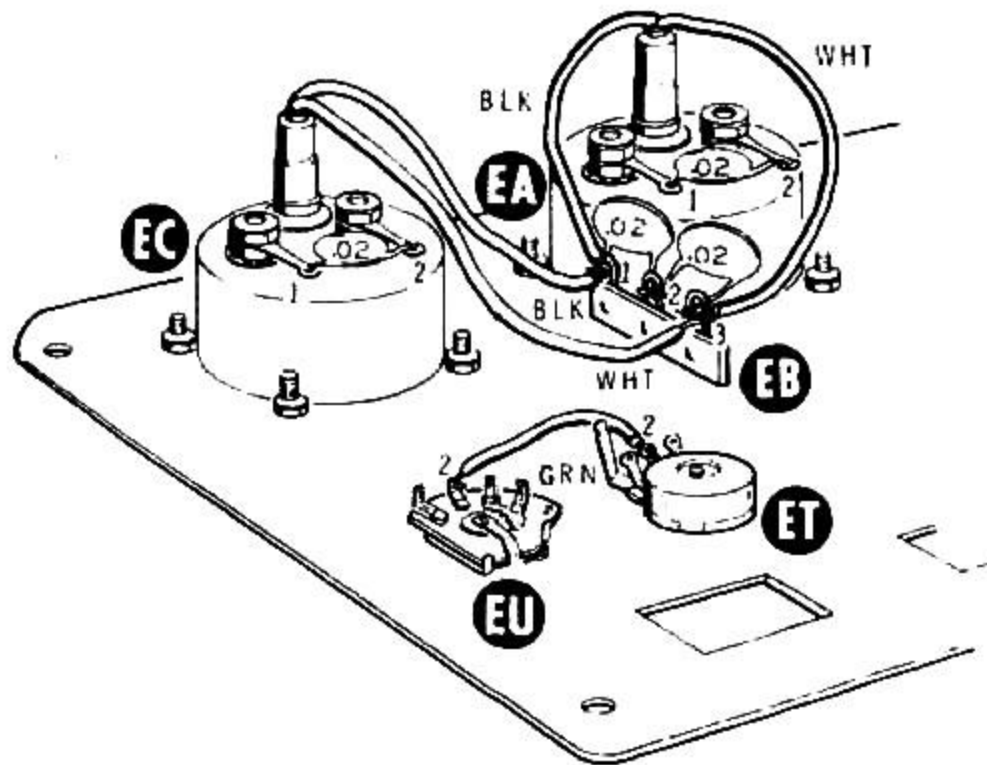

PICTORIAL 3-2

Refer to Pictorial 3-2 for the following steps.

- ( ) Connect a  $.02 \mu\text{F}$  disc capacitor between lugs 1 (NS) and 2 (NS) of meter EC.
- ( ) Connect a  $.02 \mu\text{F}$  disc capacitor between lugs 1 (NS) and 2 (NS) of meter EA.
- ( ) Cut the leads of two  $.02 \mu\text{F}$  disc capacitors to a length of  $1/2''$ . These capacitors will be used in the next two steps.
- ( ) Install a  $.02 \mu\text{F}$  disc capacitor between lugs 1 (NS) and 2 (NS) of terminal strip EB.
- ( ) Install a  $.02 \mu\text{F}$  disc capacitor between lugs 2 (S-2) and 3 (NS) of terminal strip EB.
- ( ) Cut the black pilot lamp lead from meter EC to  $3-1/2''$  and the white lead to  $4''$ .
- ( ) Connect the black pilot lamp lead coming from meter EC to lug 1 of terminal strip EB (NS).
- ( ) Connect the white pilot lamp lead coming from meter EC to lug 3 of terminal strip EB (NS).
- ( ) Cut the black pilot lamp lead coming from meter EA to  $3''$  and the white lead to  $4''$ .
- ( ) Connect the black pilot lamp lead coming from meter EA to lug 1 of terminal strip EB (NS).
- ( ) Connect the white pilot lamp lead coming from meter EA to lug 3 of terminal strip EB (NS).
- ( ) Connect a  $3-1/2''$  length of green wire from lug 2 of rotary switch EU (S-1) to lug 2 of control ET (S-1).

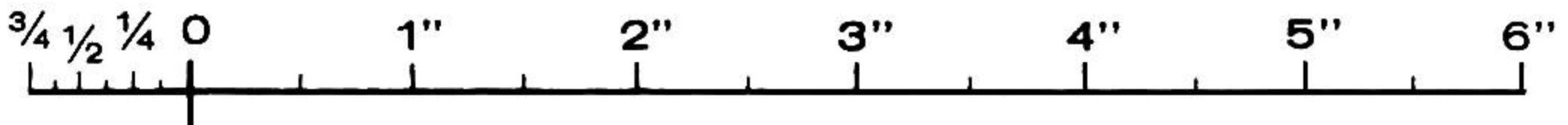

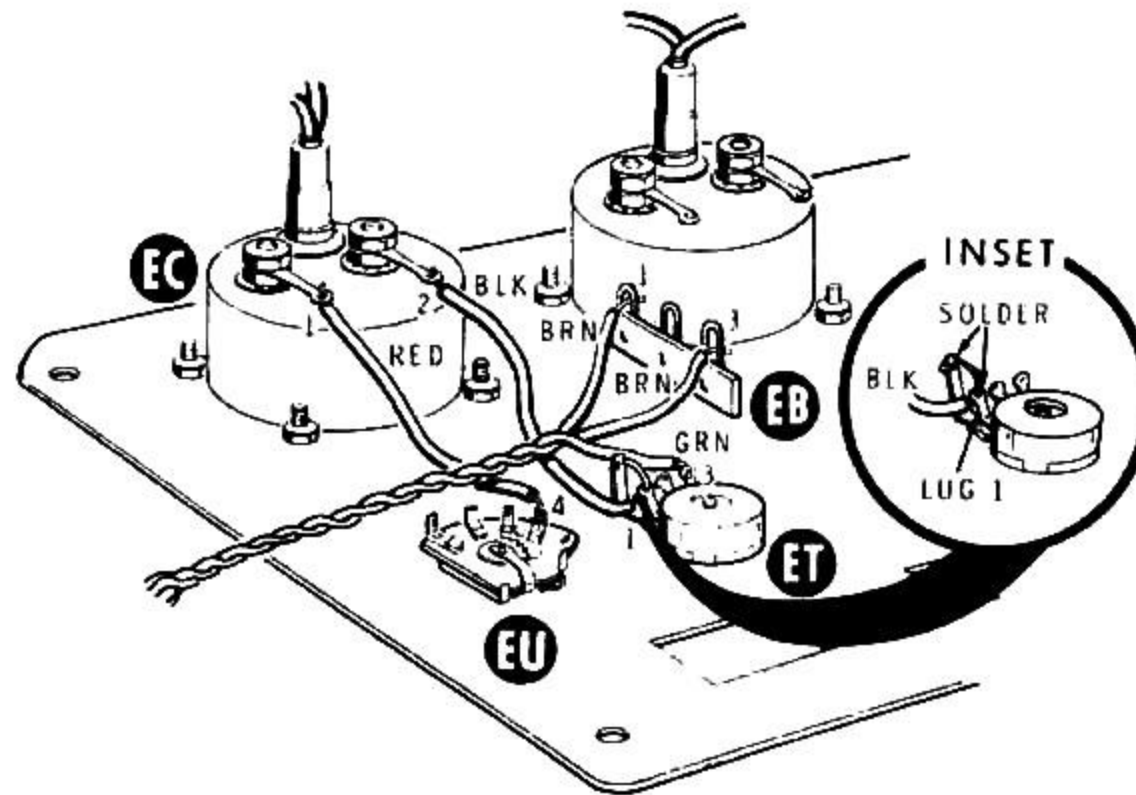

PICTORIAL 3-3

( ) Prepare the following lengths of hookup wire:

- |              |           |
|--------------|-----------|
| 3-1/2" black | 18" brown |
| 3-1/2" red   | 18" brown |
|              | 30" green |

Refer to Pictorial 3-3 for the following steps.

( ) Remove an additional 1/2" of insulation from one end of the 3-1/2" black wire. Pass this end through lug 1 of control ET (S-2) and wrap it around the control solder lug (S-1). Connect the other end of this black wire to lug 2 of meter EC (S-2).

( ) Connect a 3-1/2" length of red wire from lug 1 (marked + on the case) of meter EC (S-2) to lug 4 of rotary switch EU (S-1).

( ) Connect an 18" length of brown wire to lug 3 of terminal strip EB (S-4).

( ) Connect an 18" length of brown wire to lug 1 of terminal strip EB (S-4).

( ) Connect a 30" length of green wire to lug 3 of control ET (S-1).

( ) Gather the green wire and the two brown wires and twist them together approximately one turn per inch.

Set the front panel assembly aside until it is required in later steps.

# CHASSIS

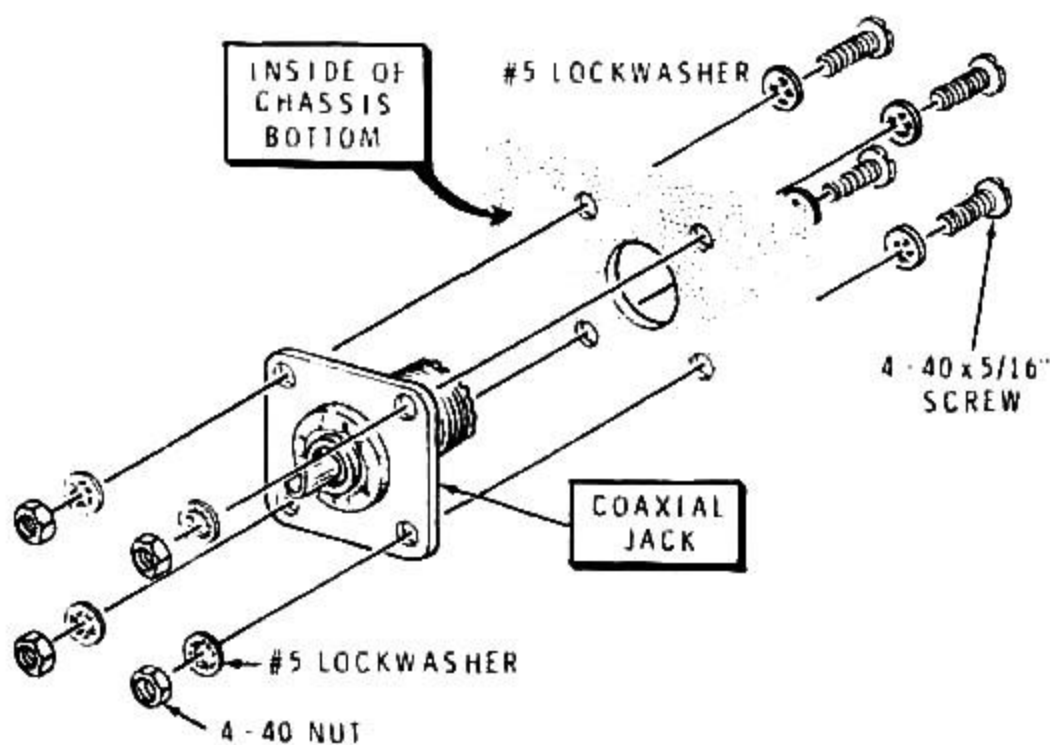

Detail 4-1A

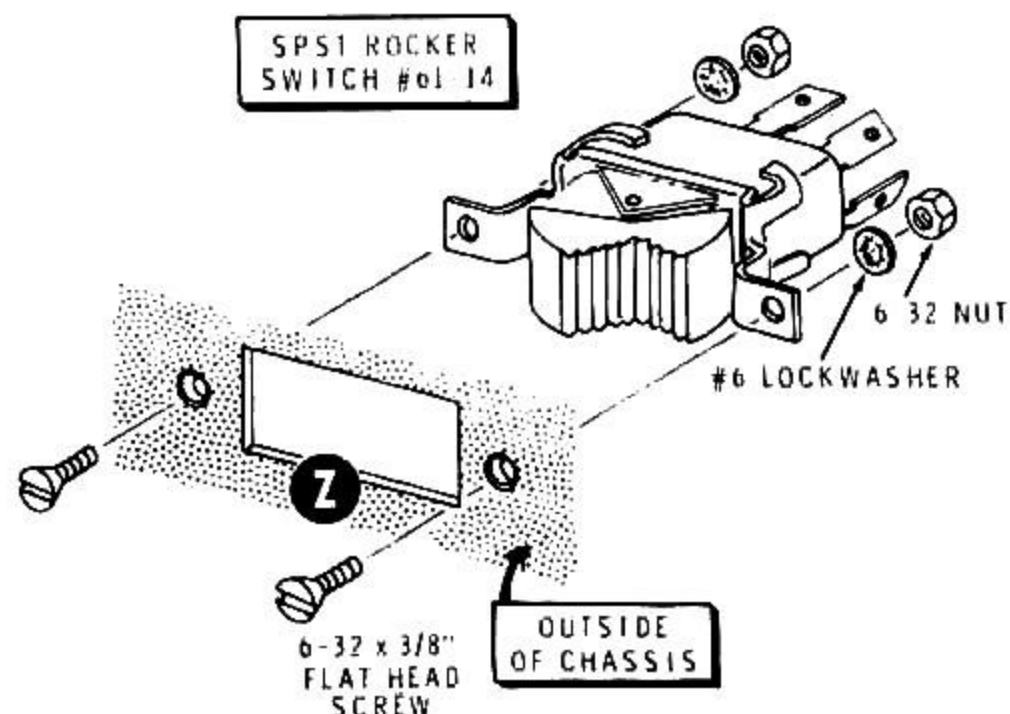

Detail 4-1C

## CHASSIS PARTS MOUNTING

Refer to Pictorial 4-1 (fold-out from Page 27) for the following steps.

- ( ) Install 1/2" rubber grommets at Y, T, AK, and AL.
- ( ) Install a 3/4" rubber grommet at AH.
- ( ) Refer to Detail 4-1A and mount a coaxial jack at A on the rear apron of the chassis. Use 4-40 x 5/16" hardware and #5 lockwashers.
- ( ) In the same manner, mount another coaxial jack at L on the rear apron.
- ( ) Refer to Detail 4-1B and mount a phono socket at U on the rear apron. Use 6-32 x 1/4" hardware. Position the ground lug toward the coaxial jack.

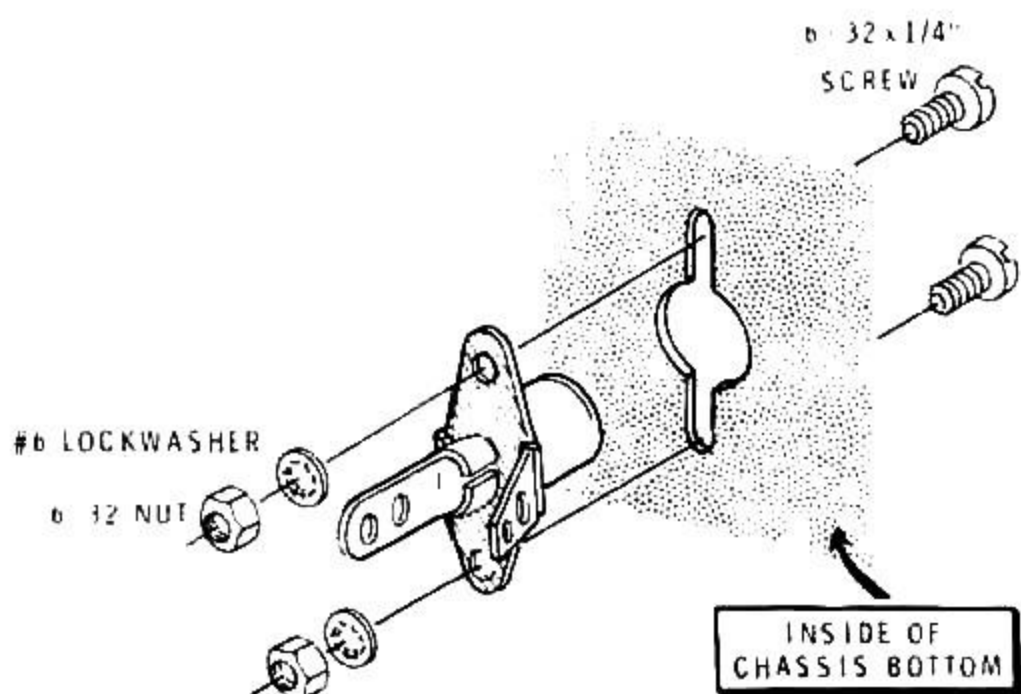

Detail 4-1B

- ( ) Similarly, mount another phono socket at X.

NOTE: In the following steps, the switch mounting holes are off center and fit in one position only.

- ( ) Refer to Detail 4-1C and mount the DPST rocker switch (#61-14) at Z on the front apron of the chassis. Use 6-32 x 3/8" flat head screws with lockwashers and nuts. Note the position of the lugs in the Pictorial.
- ( ) Similarly, mount a DPDT rocker switch (#61-15) at AN on the chassis front apron.

NOTE: Discard any loose metal clips you find in the tube socket boxes.

- ( ) Refer to Detail 4-1D and mount a 5-lug ceramic tube socket at N with a 2-lug terminal strip at AG. Use 6-32 x 11/16" hardware and fiber flat washers. Be sure to properly position the socket, and to place a lockwasher under the terminal strip mounting foot.
- ( ) Similarly, mount a 5-lug ceramic tube socket at D. Use 6-32 x 11/16" hardware and fiber flat washers. Do not use a terminal strip on this socket.
- ( ) Refer to Detail 4-1E and mount two #6 solder lugs at C. Use 6-32 x 1/4" hardware. Be sure to position the lugs as shown in the Pictorial.
- ( ) Similarly, mount two #6 solder lugs at M. Position these lugs as shown in the Pictorial.
- ( ) Similarly, mount one #6 solder lug at E.



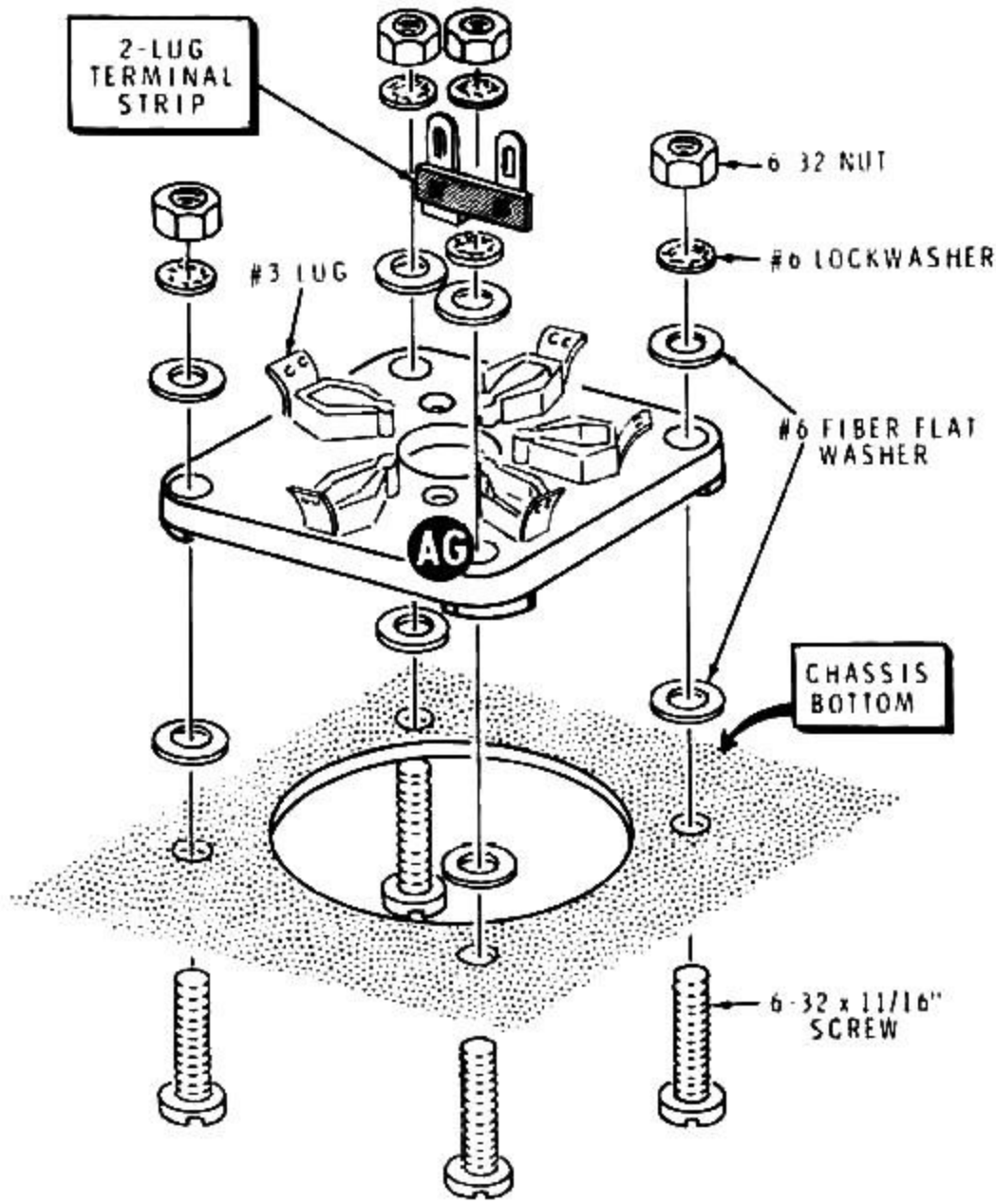

Detail 4-1D

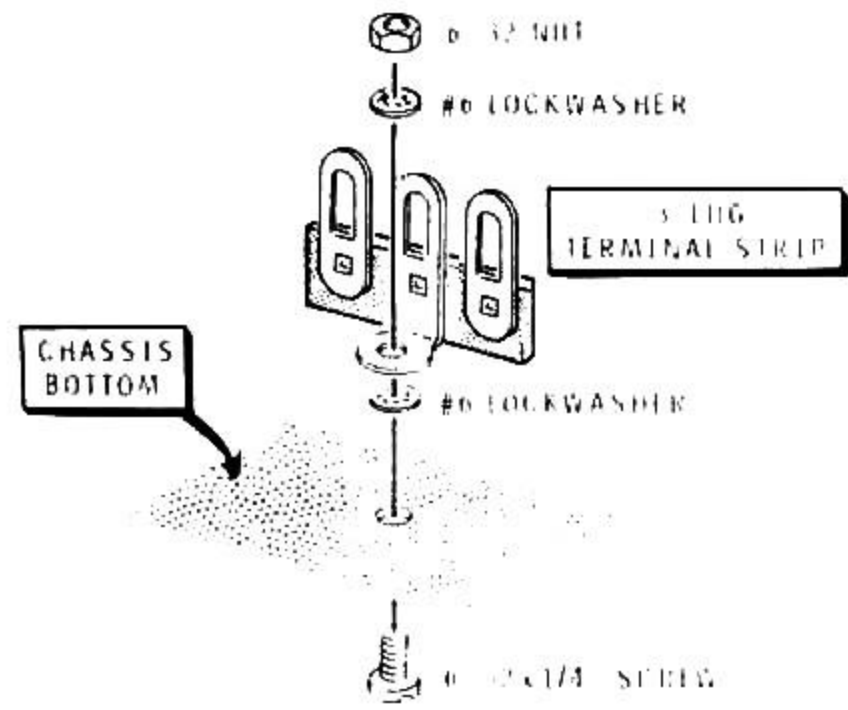

Detail 4-1F

( ) Refer to Detail 4-1F and mount a 3-lug terminal strip at P. Use 6-32 x 1/4" hardware.

( ) Refer to Detail 4-1G and mount a long solder lug at R. Use 6-32 x 1/4" hardware.

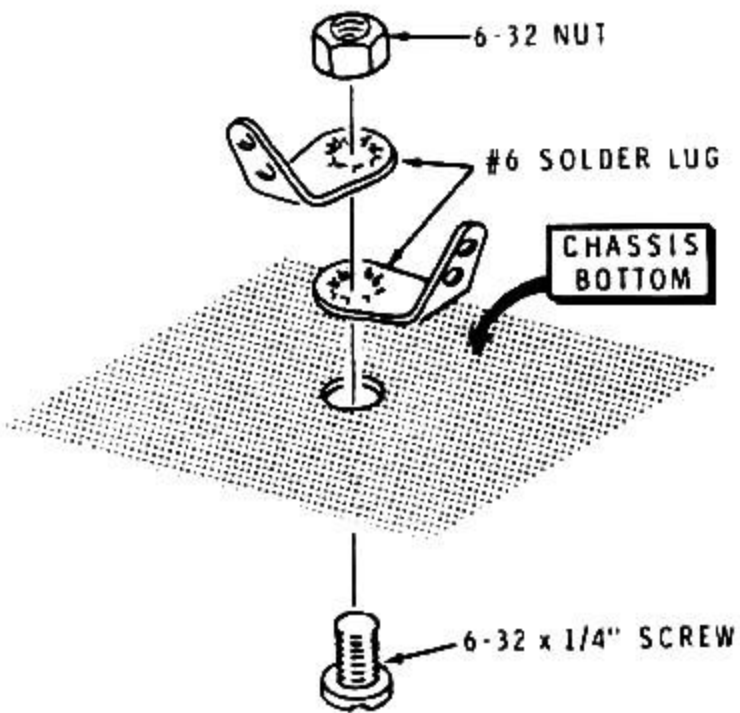

Detail 4-1E

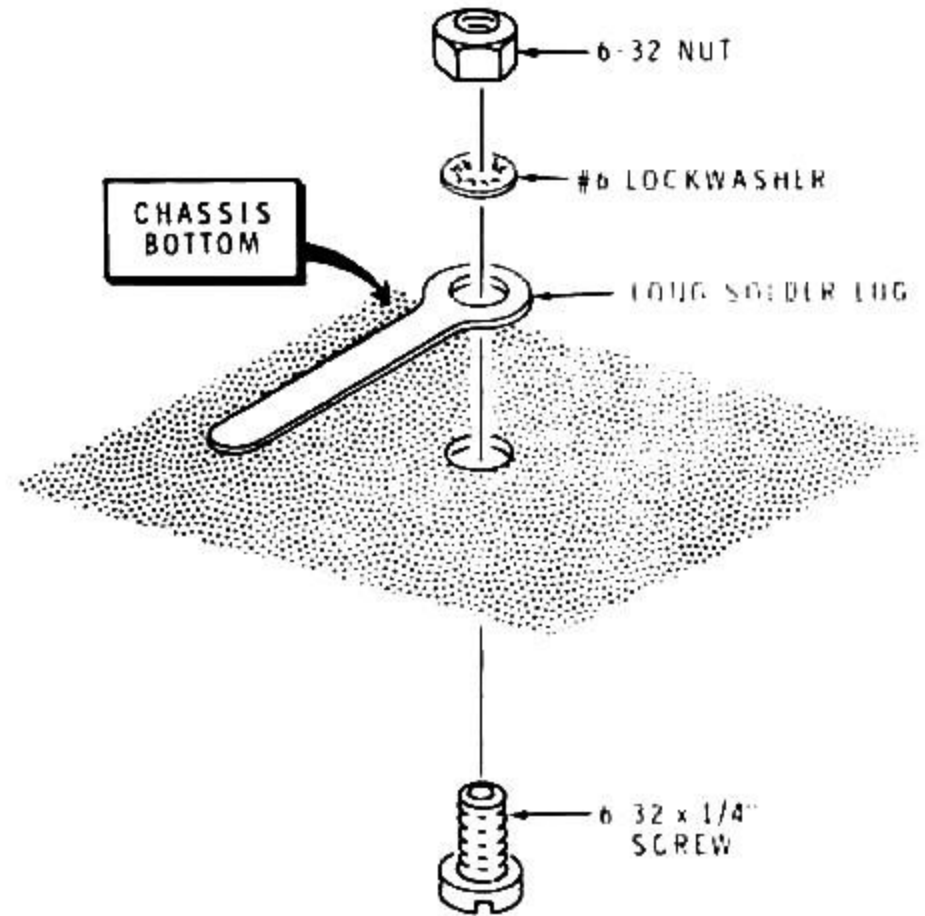

Detail 4-1G

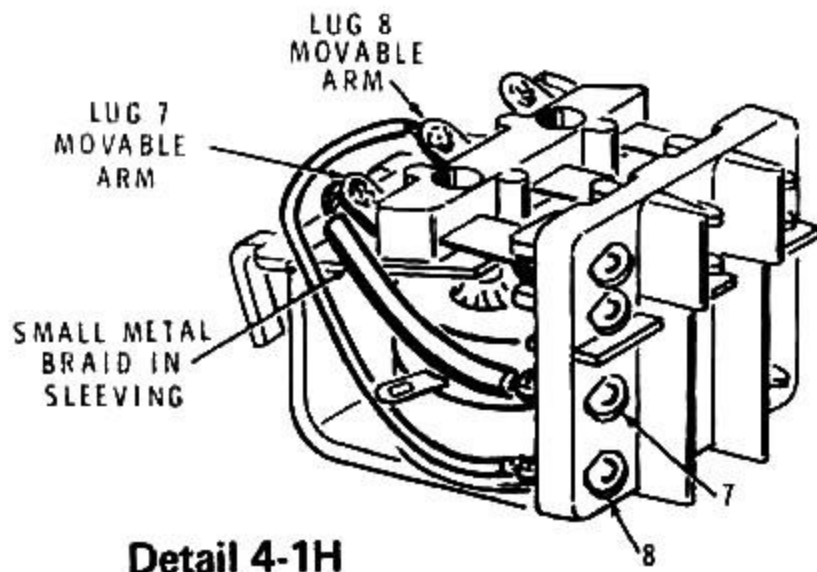

Detail 4-1H

- ( ) Install a 5/16" rubber grommet at F.

Refer to Detail 4-1H for the following steps.

- ( ) Position the relay (#69-55) with its lugs to the right as shown. Unsolder and discard the black insulated wire between lug 7 and its movable arm.

NOTE: When you solder the small metal braid in the following steps, use the minimum amount of heat necessary to secure a good connection.

IMPORTANT: Disregard any lug numbers stamped on the relays; refer to the steps and the illustrations for the correct lug numbers.

- ( ) Replace the wire discarded in the previous step with a 3-1/4" length of small metal braid that is folded in the middle and pushed through a 1" length of black sleeving. Solder one end of the braid wires to relay lug 7 and the other end to its movable arm.
- ( ) Unsolder and discard the black insulated wire between lug 8 and its arm.
- ( ) Replace the wire discarded in the previous step with a 5-1/4" length of small metal braid that is folded in the middle and pushed through a 2" length of black sleeving. Solder one end of the braid to lug 8 and the other end to its movable arm.
- ( ) Refer to Detail 4-1J and mount the relay through grommet F. Use a 6-32 x 11/16" screw and two #6 fiber shoulder washers. Do not overtighten this screw. The rubber grommet is used to provide resiliency.

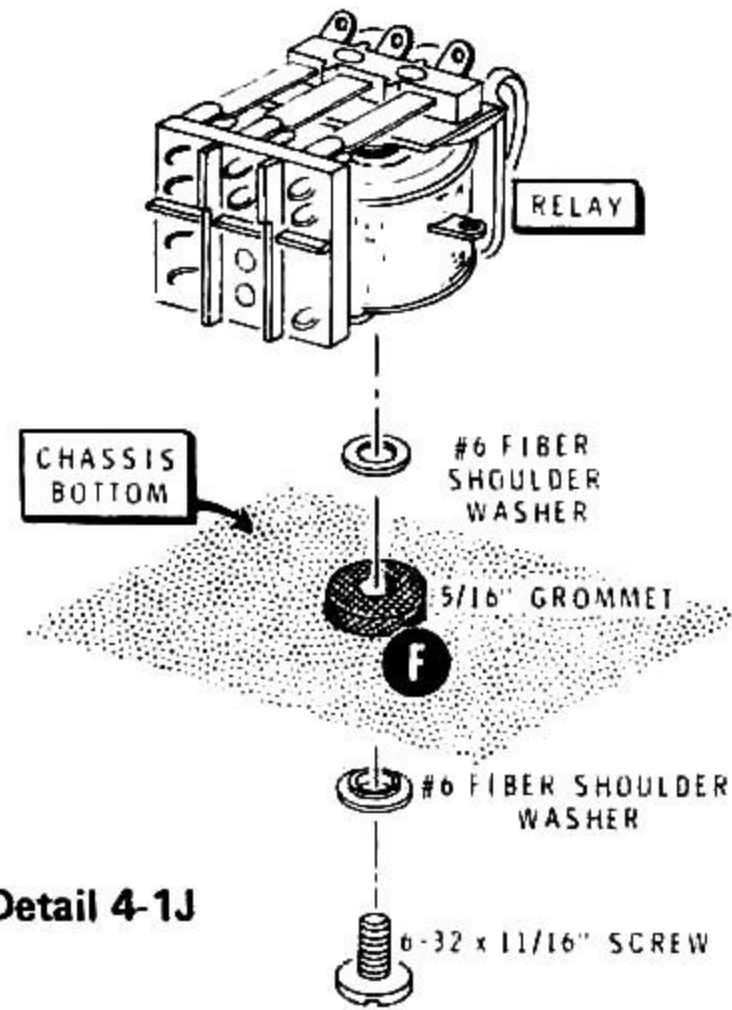

Detail 4-1J

- ( ) Inspect the relay to make sure that neither piece of metal braid can possibly touch the metal frame of the relay.
- ( ) Refer to Detail 4-1K and mount the 4-screw terminal strip at AE. Use two 6-32 x 3/8" flat head screws, two 1/2" flat washers, two 6-32 x 3/4" tapped metal spacers, and two 6-32 x 1/4" binder head screws.

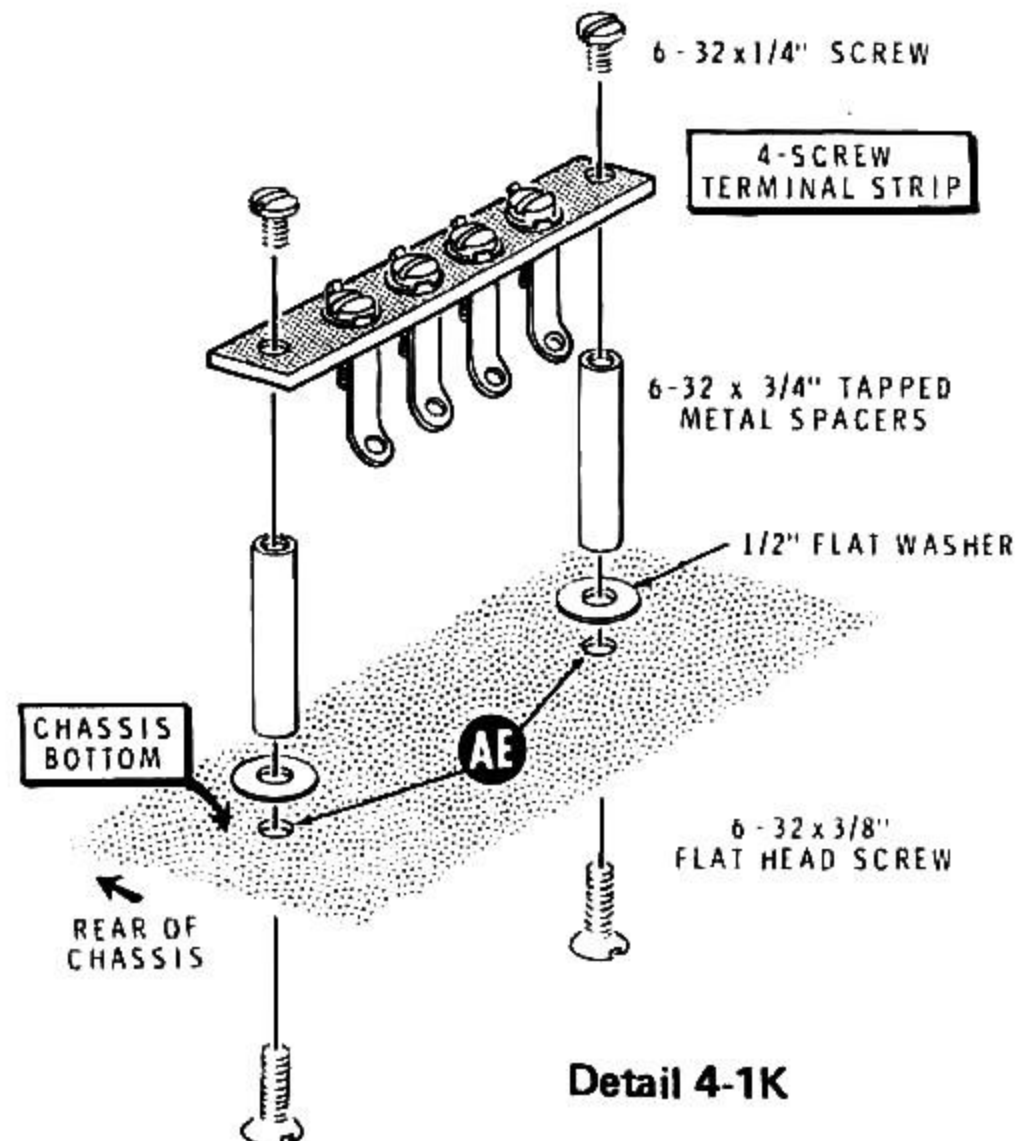

Detail 4-1K

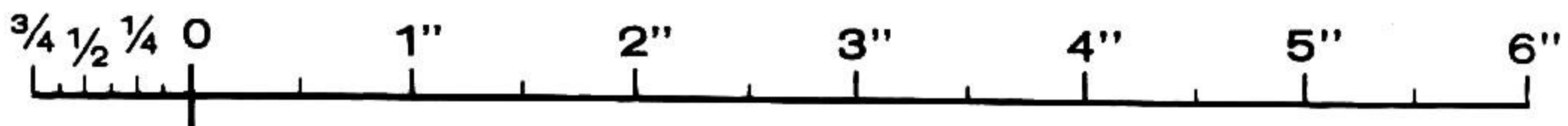

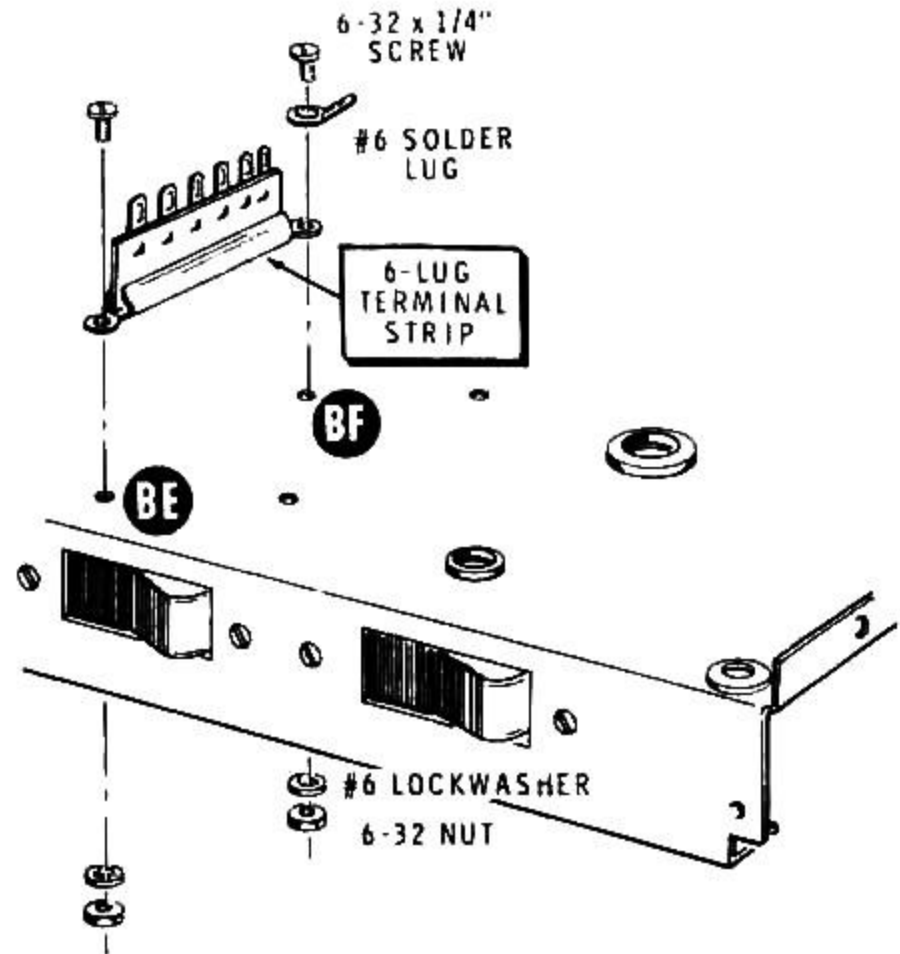
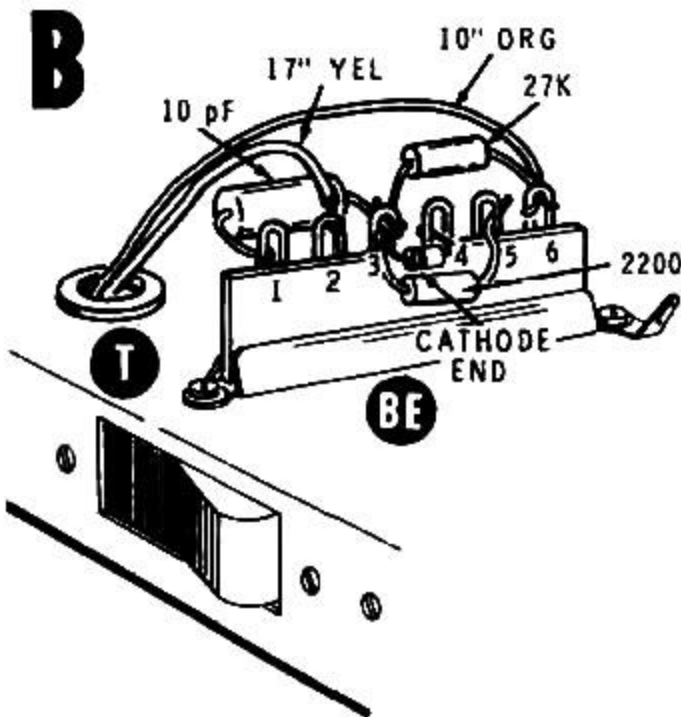
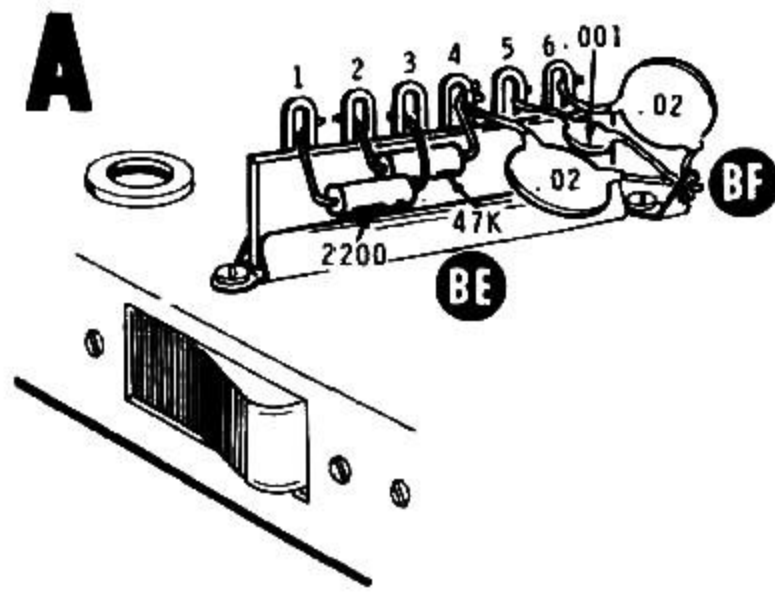

Detail 4-2A

**PICTORIAL 4-2**

**ALC WIRING**

Refer to Pictorial 4-2 for the following steps.

- ( ) Refer to Detail 4-2A and mount a 6-lug terminal strip on the top of the chassis at holes BE and BF with 6-32 x 1/4" hardware. Use a #6 solder lug at BF only.
- Refer to Part A of the Pictorial for the next five steps. Note the positions of the components.
- ( ) Connect a 47 kΩ (yellow-violet-orange) resistor from lug 2 (NS) to lug 4 (NS) of terminal strip BE.
- ( ) Connect a 2200 Ω (red-red-red) resistor from lug 1 (NS) to lug 3 (NS) of terminal strip BE.
- ( ) Connect a .02 μF disc capacitor from lug 4 of terminal strip BE (NS) to solder lug BF (NS).
- ( ) Connect a 500 volt (smaller) .001 μF disc capacitor from lug 5 of terminal strip BE (NS) to solder lug BF (NS).

- ( ) Connect a .02 μF disc capacitor from lug 6 of terminal strip BE (NS) to solder lug BF (S-3).

Refer to Part B of the Pictorial for the next eight steps.

- ( ) Prepare a 10" length of orange hookup wire and a 17" length of yellow hookup wire.
- ( ) Connect one end of the orange wire to lug 6 of terminal strip BE (NS).
- ( ) Connect one end of the yellow wire to lug 2 of terminal strip BE (S-2).
- ( ) Pass the free ends of the yellow and the orange wires down through grommet T. To temporarily secure the ends of these wires, they can be passed up through some other hole in the chassis.
- ( ) Connect a 2200 Ω (red-red-red) resistor from lug 3 (NS) to lug 5 (S-2) of terminal strip BE.
- ( ) Connect a 27 kΩ (red-violet-orange) resistor from lug 3 (NS) to lug 6 (S-3) of terminal strip BE.
- ( ) Connect the cathode lead of a silicon diode (#56-24, yellow-green-gray) to lug 3 (NS), and the anode lead to lug 4 (S-3) of terminal strip BE.
- ( ) Connect a 10 pF (may be marked 10 μμF) tubular ceramic capacitor from lug 3 (S-5) to lug 1 (NS) of terminal strip BE.

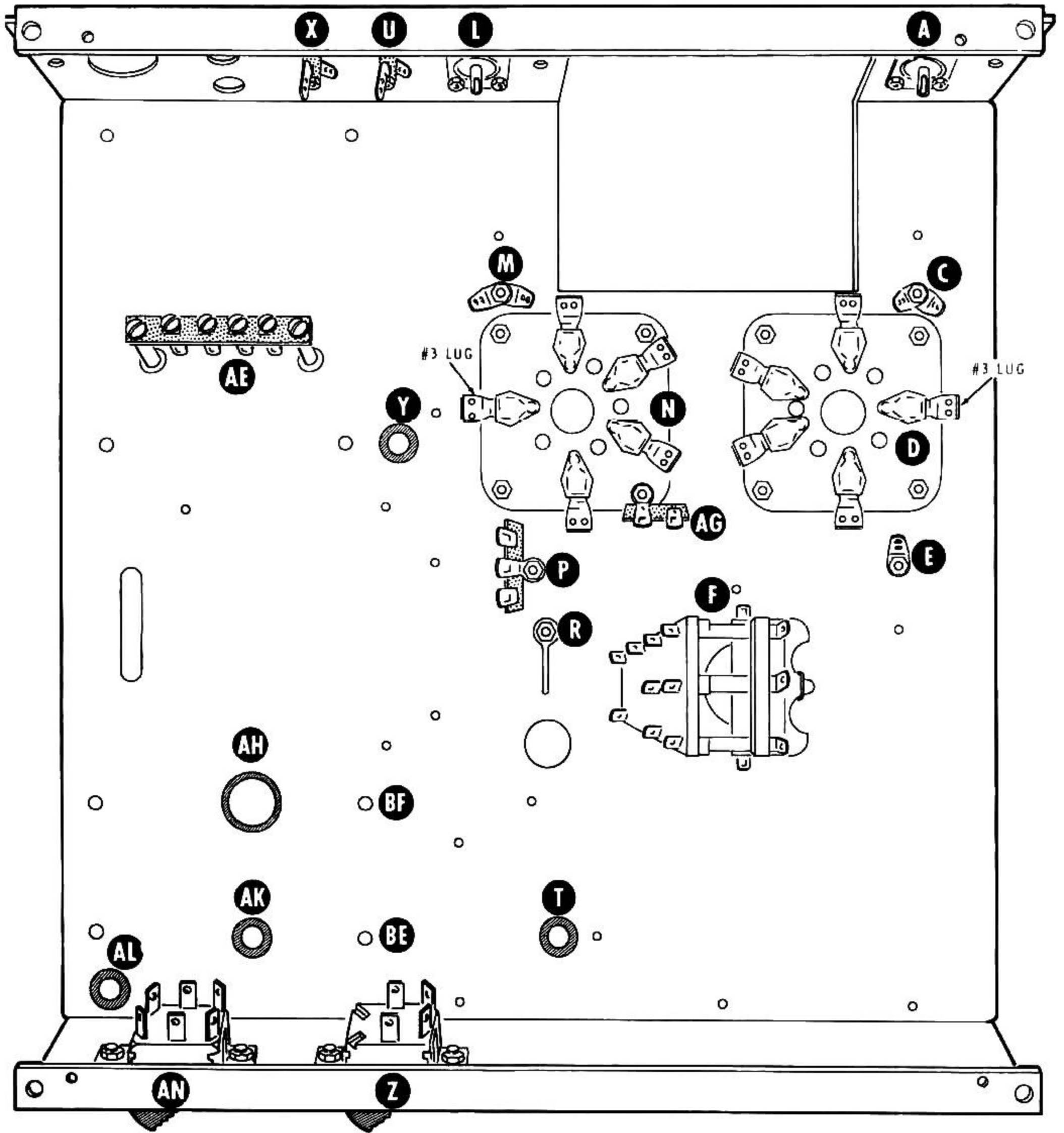

**PICTORIAL 4-1**

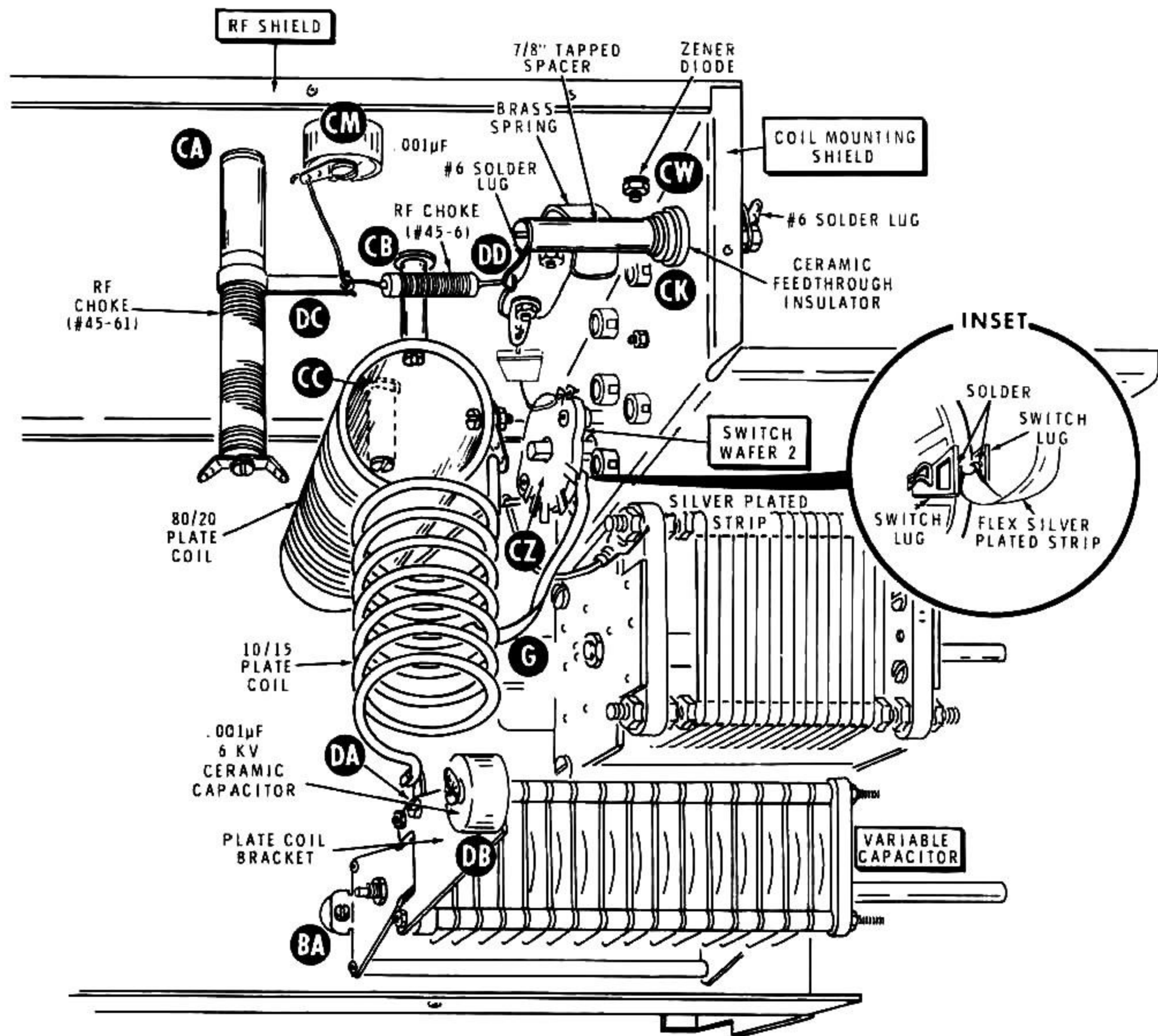

**PICTORIAL 4-5**

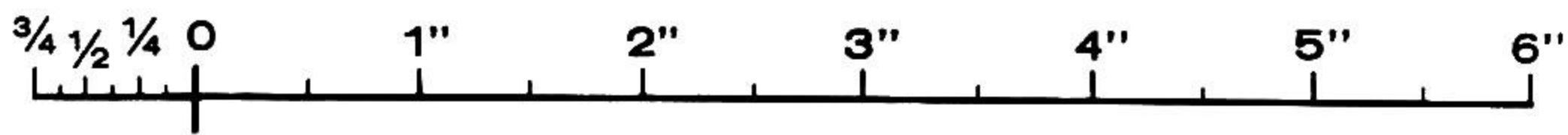

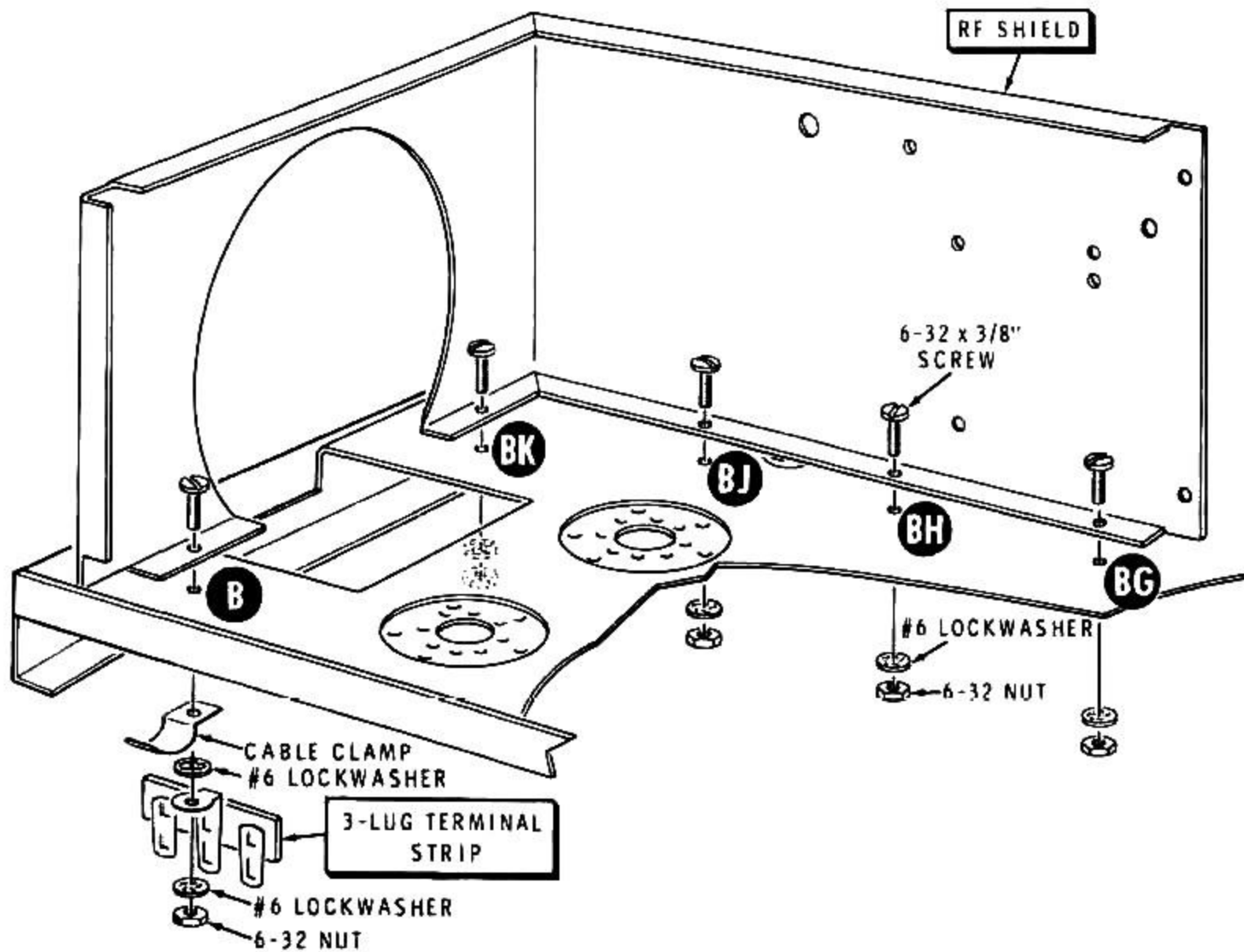

Detail 4-3A

**TOP-CHASSIS ASSEMBLY**

Refer to Pictorial 4-3 for the following steps.

- ( ) Refer to Detail 4-3A and mount the RF shield (#206-493) on the top of the chassis. At BG, BH, BJ, and BK, use 6-32 x 3/8" screws. At B, use a 6-32 x 3/8" binder head screw with a 3-lug terminal strip, a cable clamp, two #6 lockwashers, and a 6-32 nut.

- ( ) Refer to Detail 4-3B and mount the brass spring (#258-115) at CD and CE on the RF shield. Use 6-32 x 3/8" flat head hardware with a #6 solder lug at CE. When the hardware is tightened, the end of the brass strip will contact the upper lip of the RF shield.
- ( ) Refer to Detail 4-3C and cut one lead of a 500 pF mica capacitor (may be marked ".0005") to a length of 3/8". Connect this lead to the solder lug at CE (S-1). The other lead will be connected later.

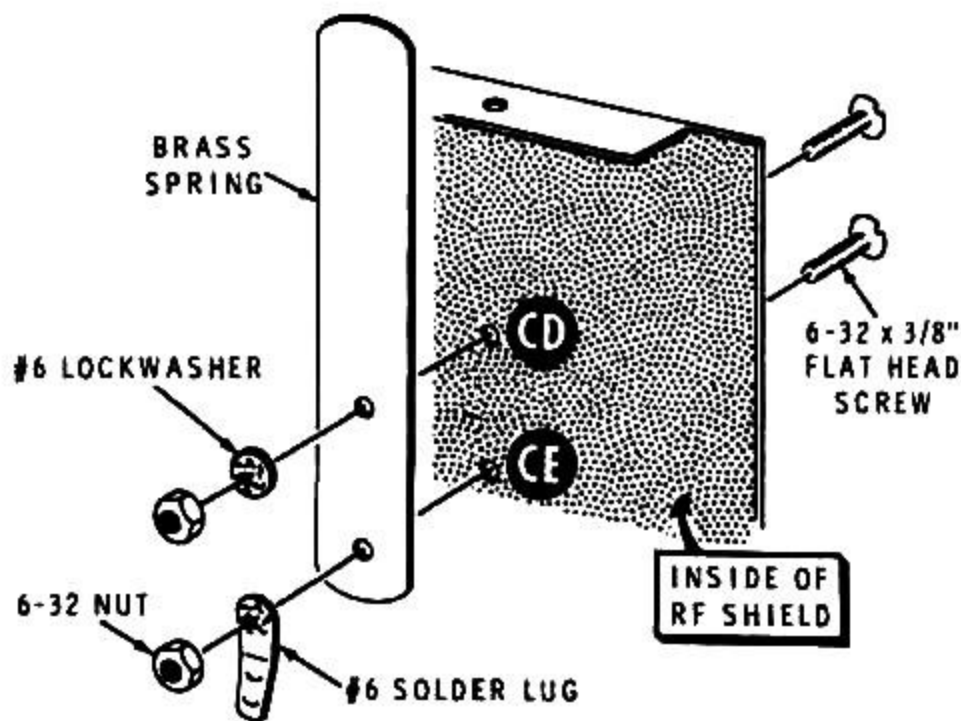

Detail 4-3B

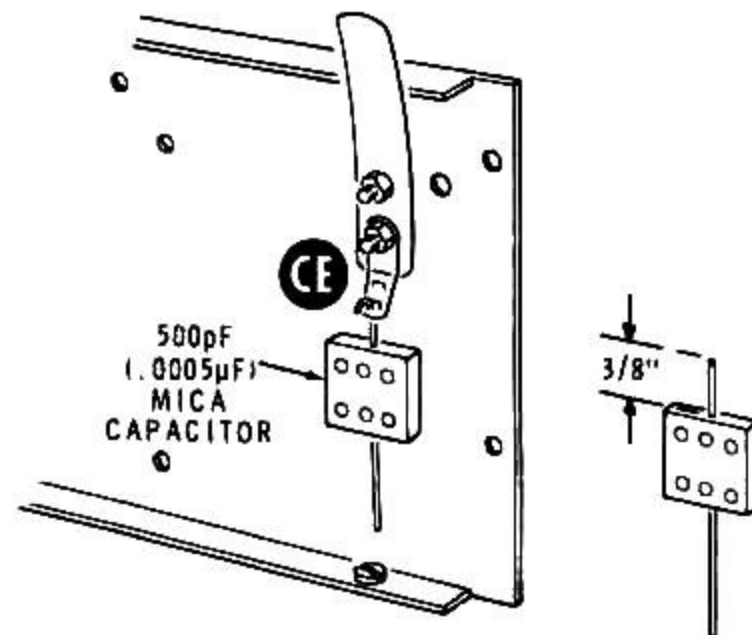

Detail 4-3C

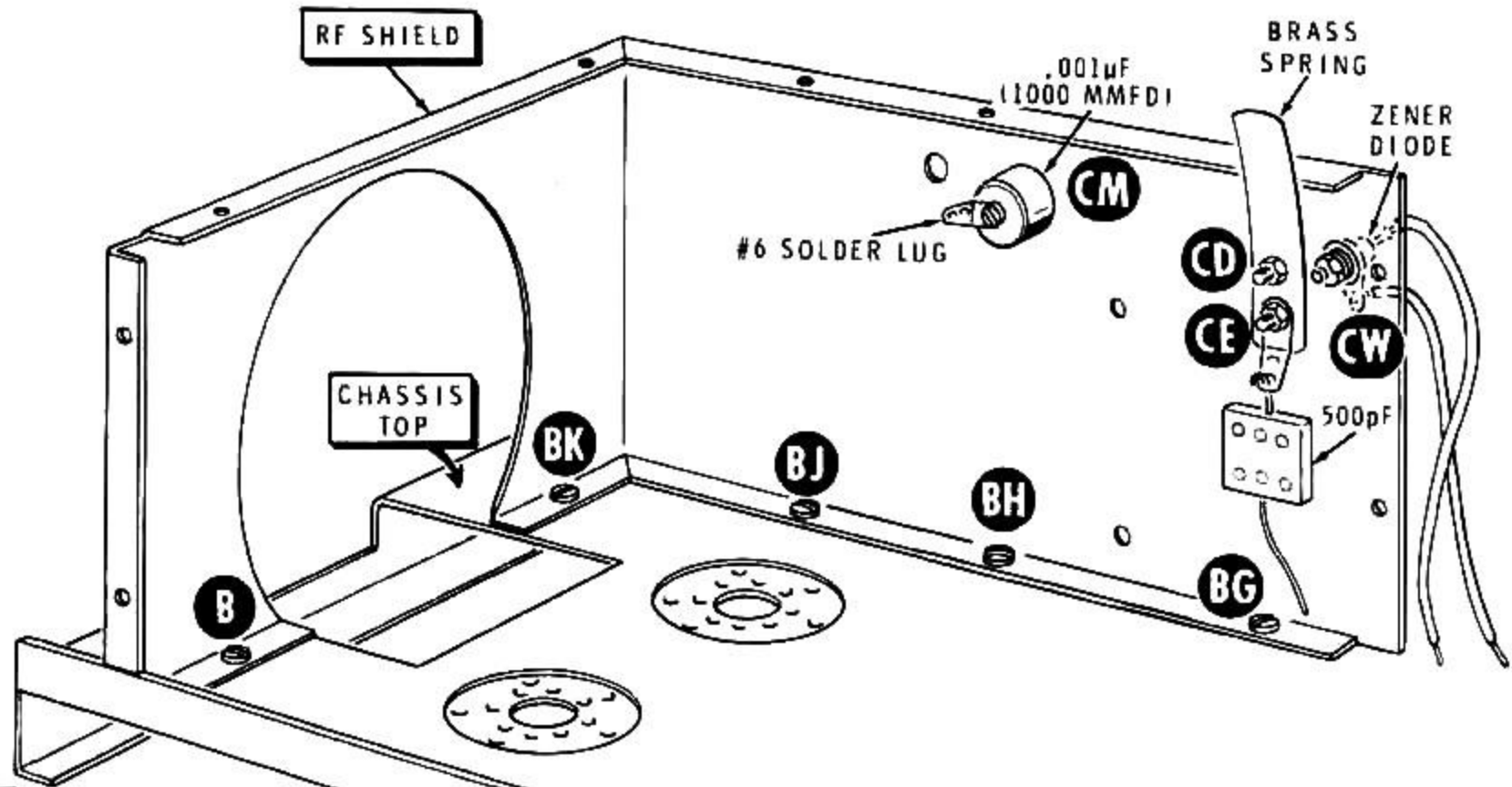

PICTORIAL 4-3

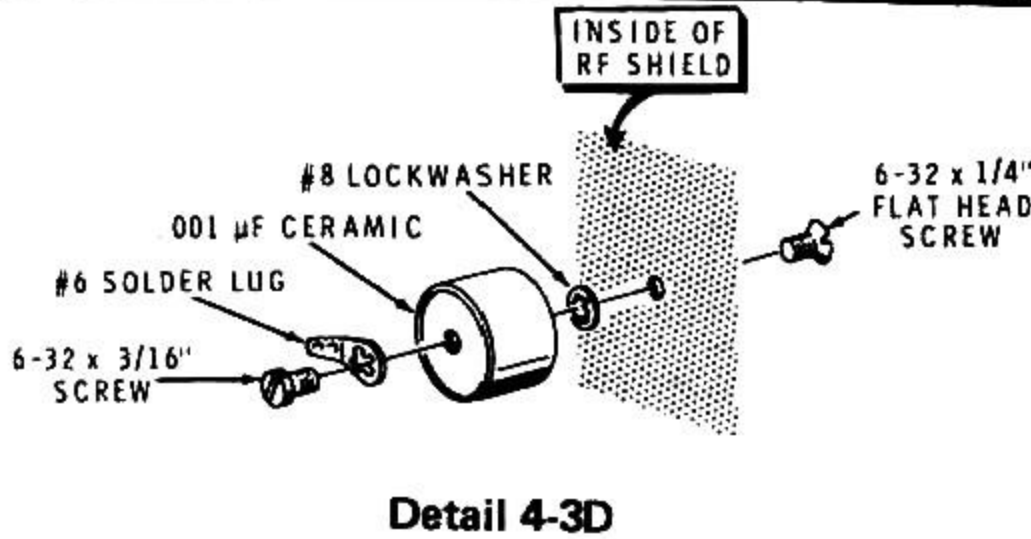

Detail 4-3D

- ( ) Bend the end of the solder lug up away from the chassis at an angle of approximately 45 degrees.
- ( ) Prepare two 3" lengths of small black stranded wire. Connect one end of one wire to the solder lug at CW (S-1). Connect one end of the other 3" wire to the solder terminal on the zener diode (S-1). The other ends of these wires will be connected later.

- ( ) Refer to Detail 4-3D and mount a .001 µF ceramic capacitor (#21-165) at CM on the inside of the RF shield (this capacitor may be marked 1000 MMFD). Use a 6-32 x 1/4" flat head screw with a #8 lockwasher between the capacitor and the RF shield.

- ( ) Install a #6 solder lug on the other terminal of the capacitor with a 6-32 x 3/16" screw. Position the solder lug as shown.

- ( ) Refer to Detail 4-3E and install the zener diode at CW on the outside of the RF shield with the mounting stud and nut on the same side of the shield as the brass spring, as shown in the Pictorial. Coat both sides of each mica washer with silicone grease before you install it. Make sure the nylon bushing is centered in the hole and that the solder lug points toward the chassis. Tighten the nut firmly, but do not overtighten.

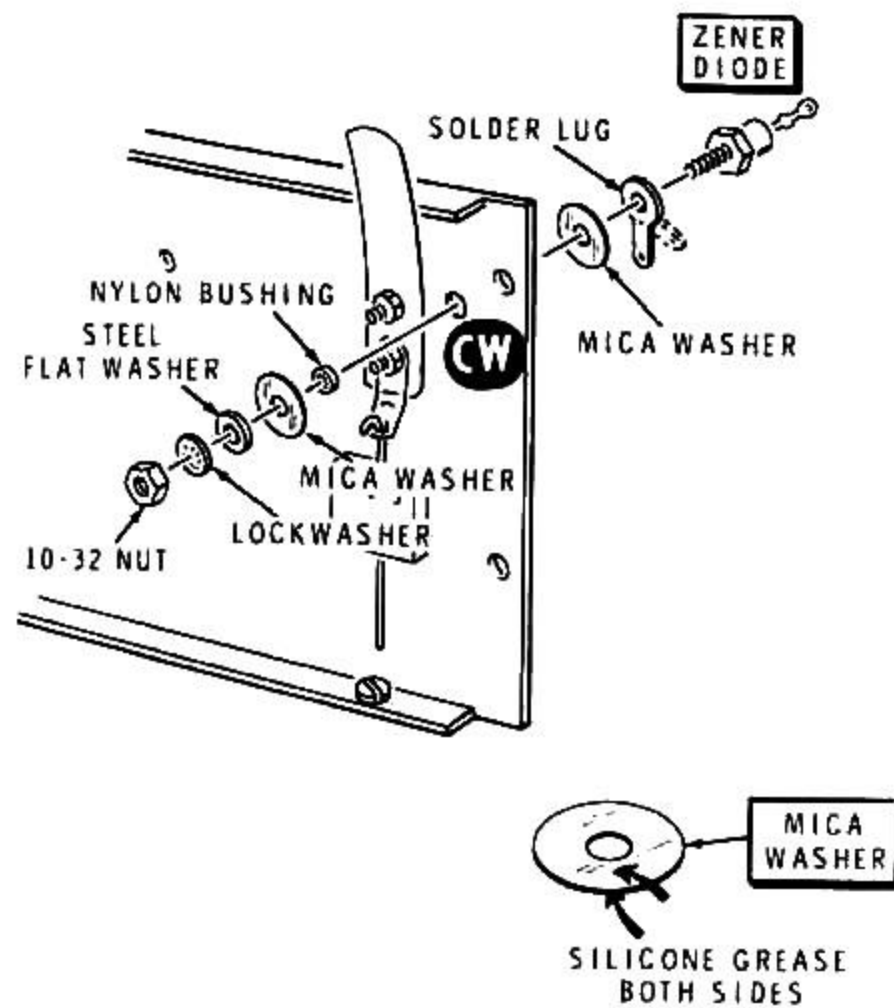

Detail 4-3E

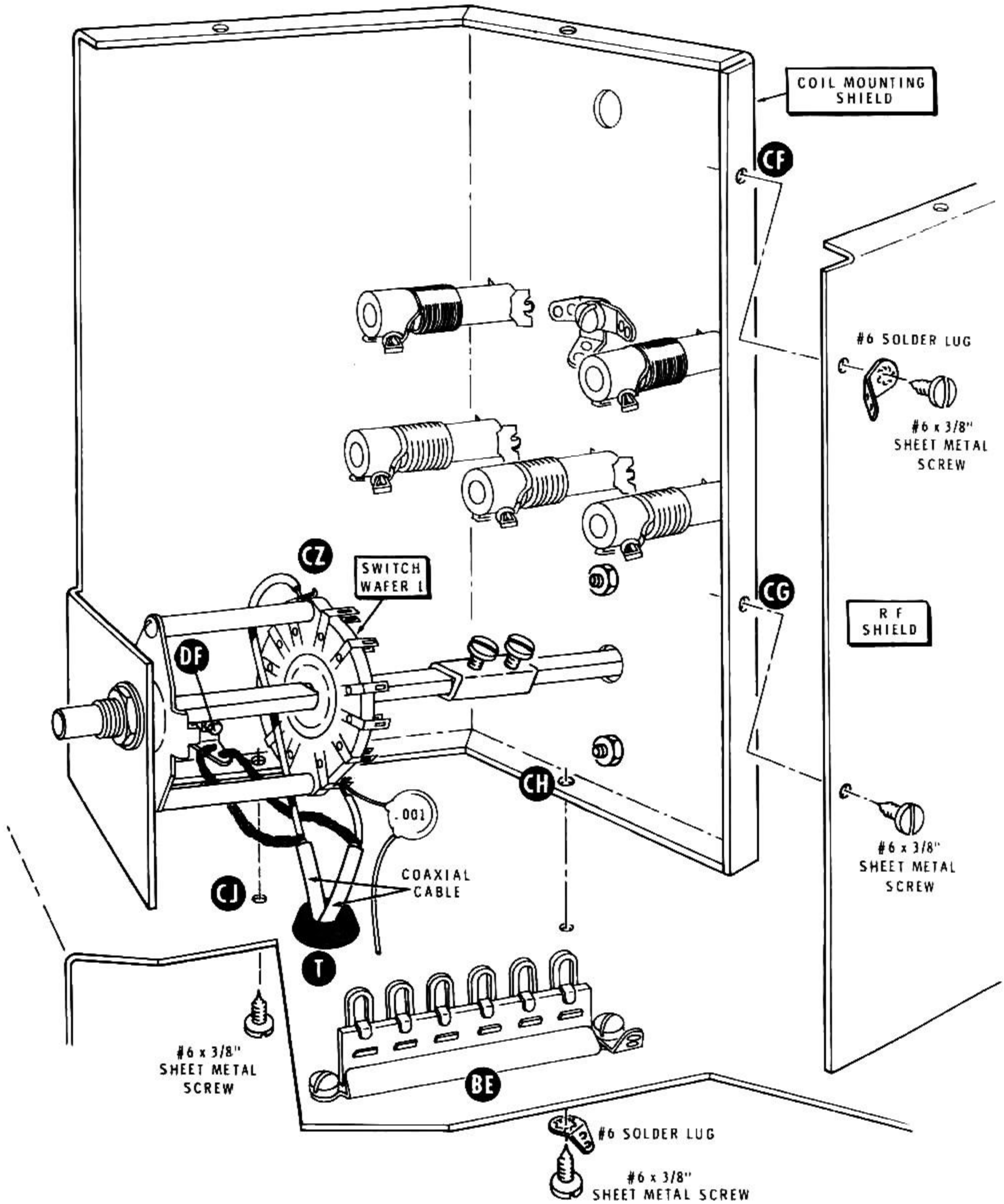

PICTORIAL 4-4



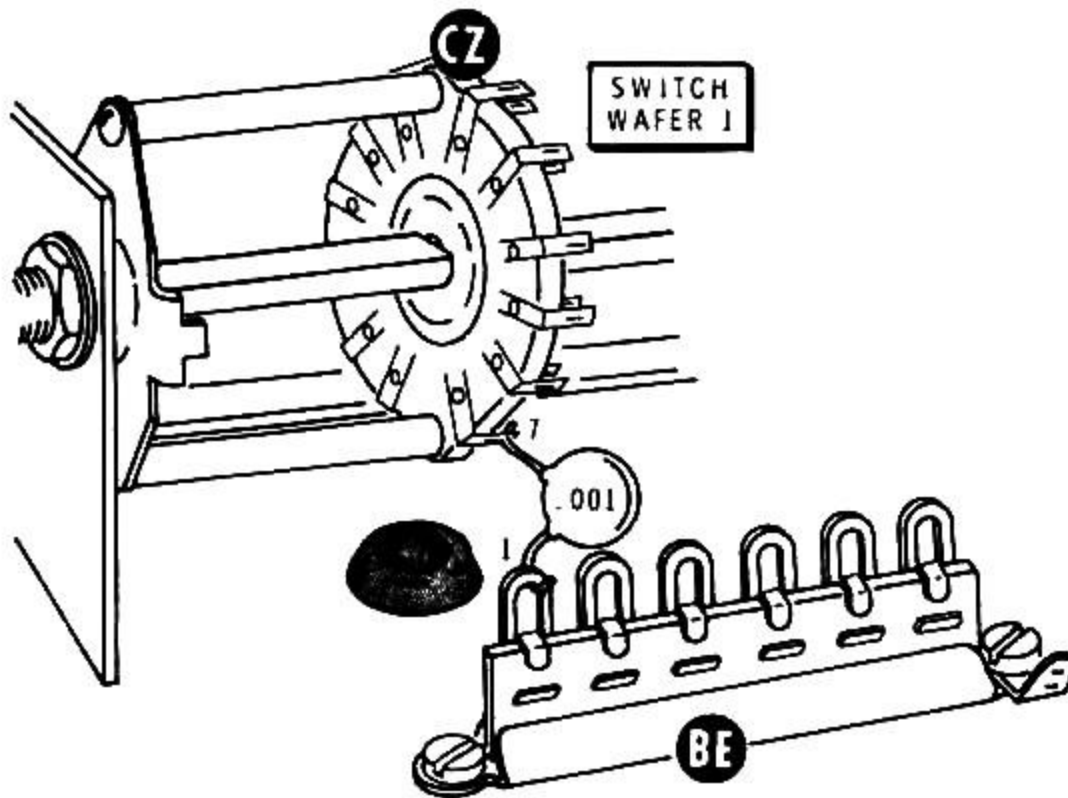

Detail 4-4A

Refer to Pictorial 4-4 for the following steps. For clarity, only the coil mounting shield is shown.

- ( ) Start the ends of the two coaxial cables coming from wafer 1 of switch CZ down through grommet T, and lower the input coil assembly down onto the chassis. Pull the two coaxial cables through the grommet as you lower the assembly.
- ( ) From the bottom of the chassis, install a #6 sheet metal screw and a #6 solder lug at CH in the coil mounting shield.
- ( ) From the bottom of the chassis, install a #6 sheet metal screw at CJ in the coil mounting shield.
- ( ) Make sure none of the parts on terminal strip BE contact any part on switch CZ.
- ( ) Install a #6 sheet metal screw and a #6 solder lug at CF. Note the position of the solder lug.
- ( ) Install a #6 x 3/8" sheet metal screw at CG.
- ( ) Refer to Detail 4-4A and connect the free lead of the .001 disc capacitor from lug 7 of the switch wafer to lug 1 of terminal strip BE (S-3).

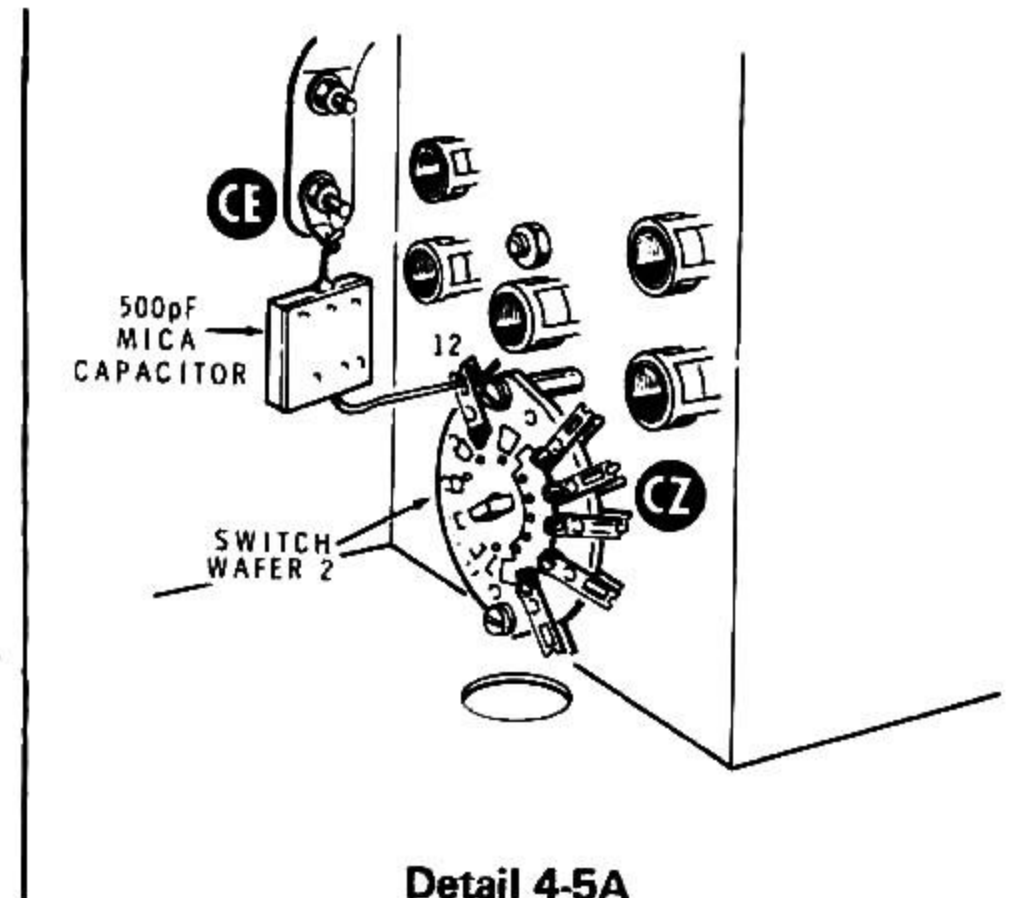

Detail 4-5A

Refer to Pictorial 4-5 (fold-out from Page 28) for the following steps.

- ( ) Refer to Detail 4-5A and connect the free end of the 500 pF mica capacitor at CE to lug 12 of rotary switch CZ wafer 2 (S-3). Be sure the capacitor lead is soldered to both lugs.

Refer to Detail 4-5B for the next two steps.

- ( ) Install two 7/8" tapped spacers on the 80/20 plate coil (#40-1666). Use 6-32 x 1/4" binder head screws.
- ( ) Mount the plate coil assembly at CB and CC on the inside of the RF shield. Be sure to position the coil so the taps are on the side toward the brass spring, and so the winding with the larger number of turns is toward CC. Use 1/2" flat washers and 6-32 x 3/8" flat head screws.

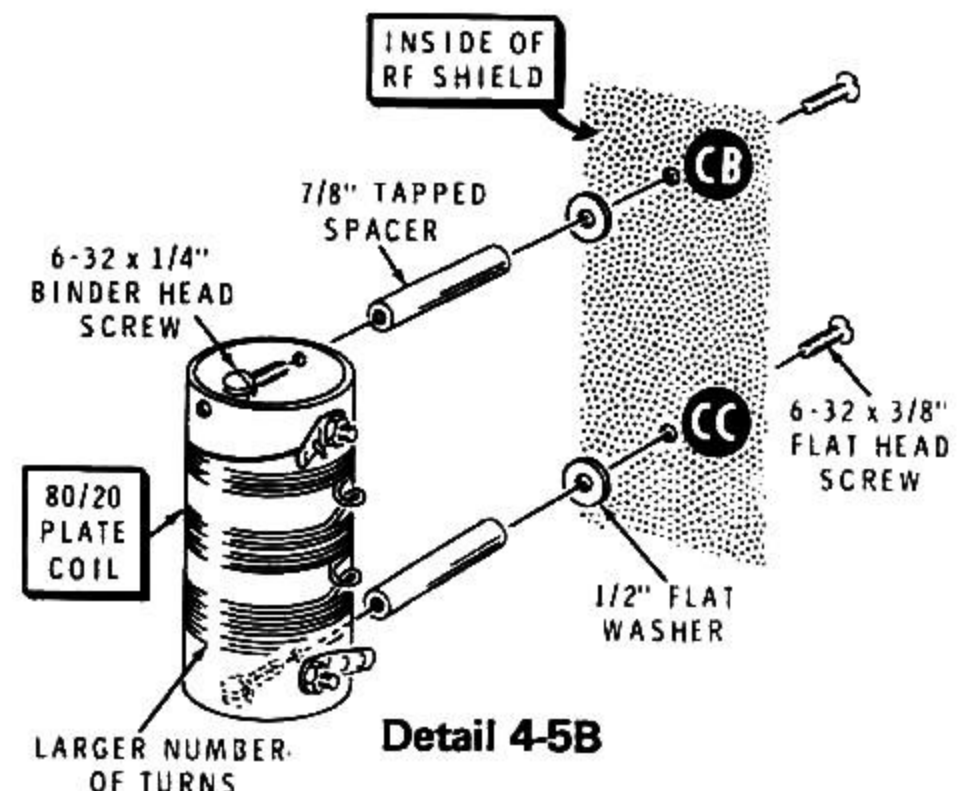

Detail 4-5B

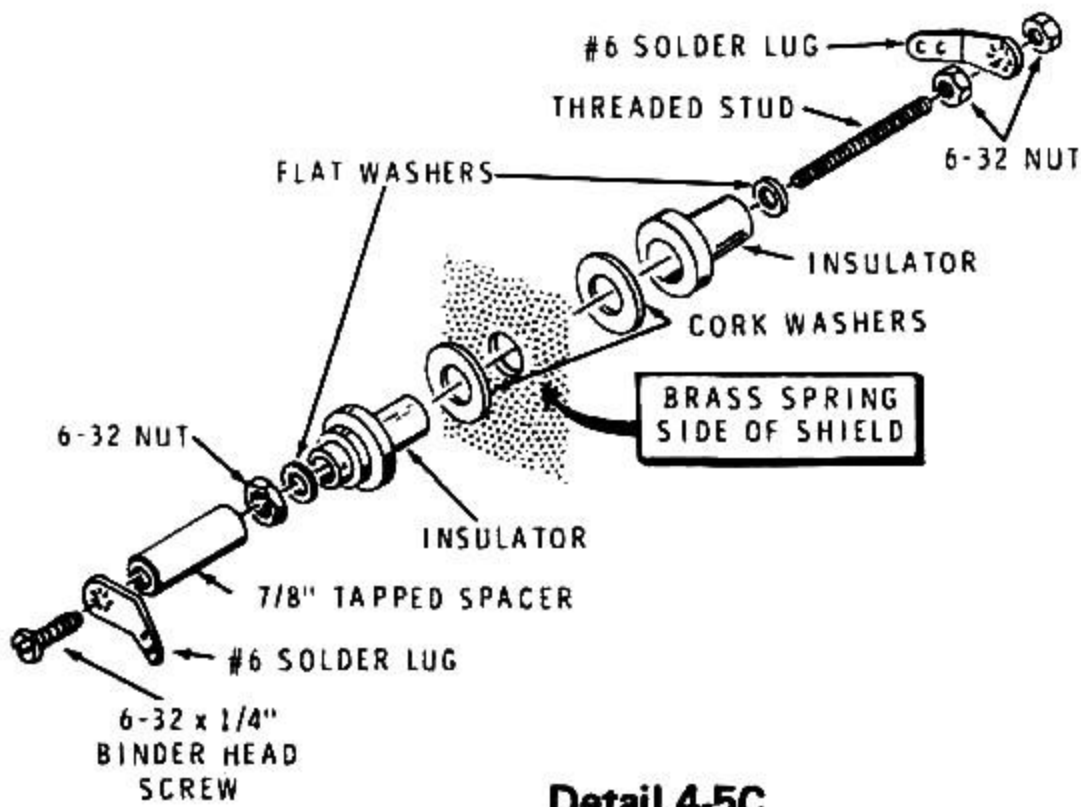

Detail 4-5C

( ) Refer to Detail 4-5C and install a ceramic feedthrough insulator (#71-2) at CK. In addition to the parts in the plastic bag, use a 7/8" tapped spacer, two #6 solder lugs, and a 6-32 x 1/4" binder head screw. Before the spacer is screwed onto the threaded stud running through the insulator, hold the brass spring down so it will bear against the under side of the installed spacer as shown in the Pictorial. Discard the unused nut.

NOTE: In the following steps, wires will be connected between wafer 2 of switch CZ and the taps on the plate coil. Each wire should be fitted before it is soldered in place. The end of each wire going through the switch lugs must first be flattened as shown in the inset drawing of Detail 4-5E. **DO NOT** use the switch lugs to hold one end of the wire when forming it, as the switch lugs and the ceramic switch wafer can be damaged.

When soldering wires to the switch, make sure the wire is soldered to both switch lugs. After you fit the wires, cut off any excess wire lengths.

Refer to Detail 4-5D for the switch lug numbering system. The Detail shows the switch rotor as it was positioned when the shaft was installed (viewed from the rear).

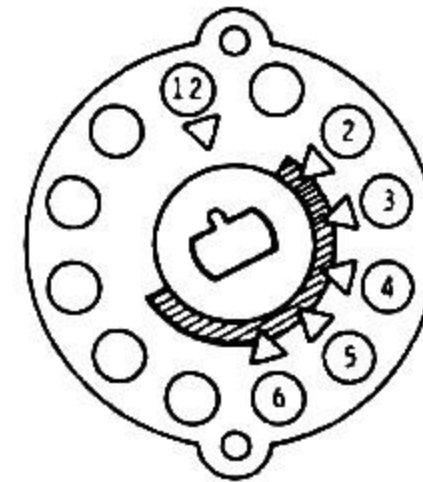

Detail 4-5D

Refer to Detail 4-5E and connect small bare wires from wafer 2 of rotary switch CZ to the taps on the plate coil as follows. Be sure to connect to both lugs at each switch position.

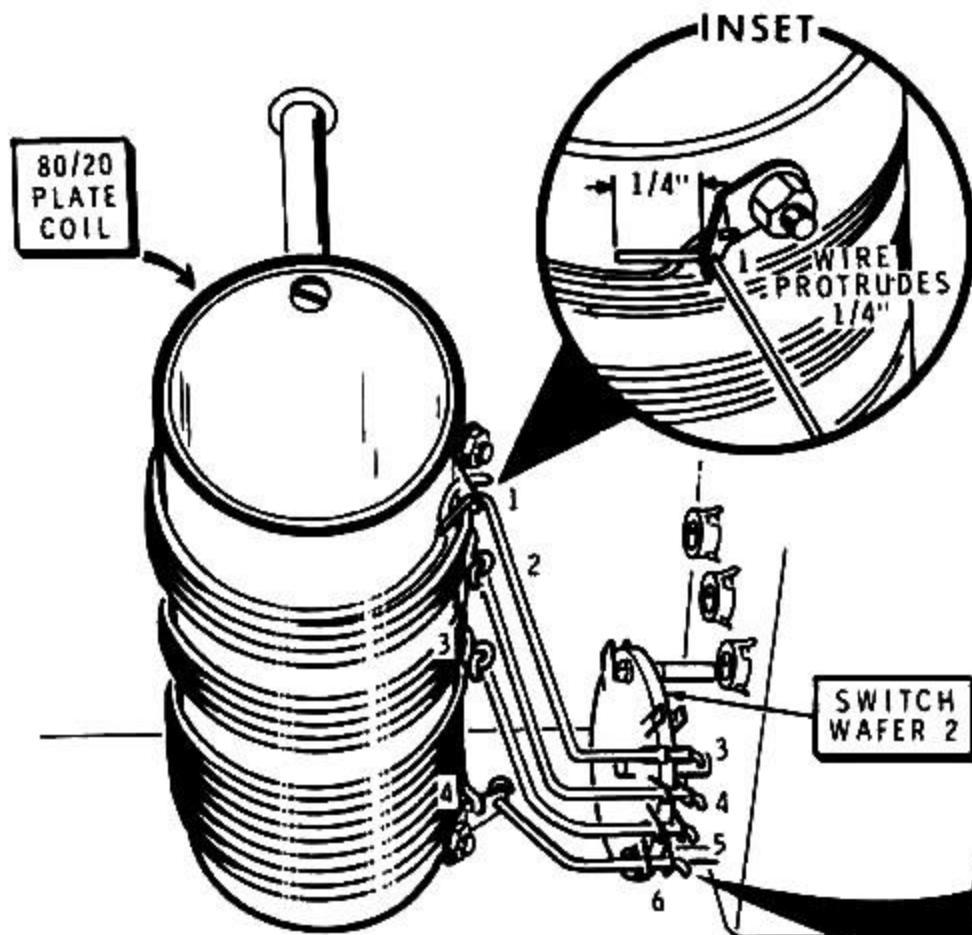

Detail 4-5E

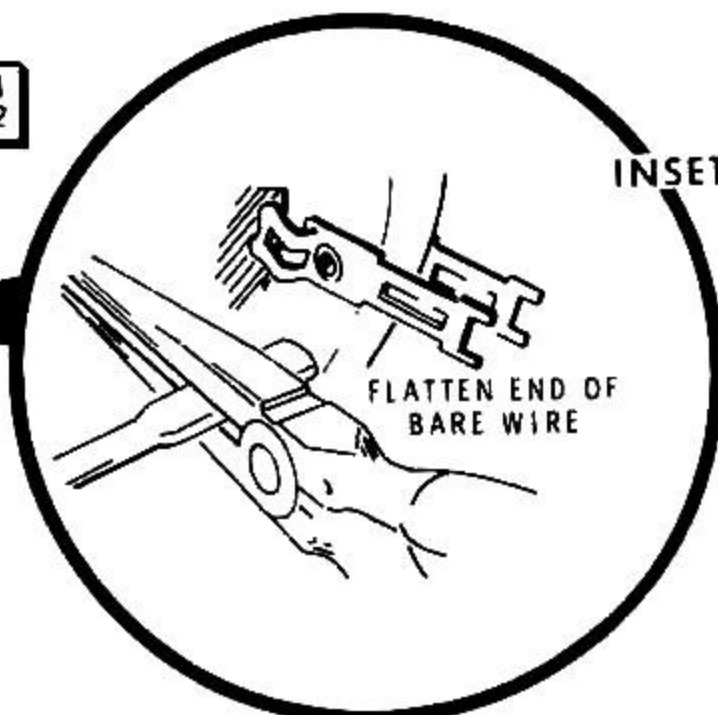

INSET

Wire Length	Switch Lug No.	Coil Tap
( ) 1-1/2"	6 (S-3)	4 (S-1)
( ) 2-1/2"	5 (S-3)	3 (S-1)
( ) 3"	4 (S-3)	2 (S-1)
( ) 3-1/2"	3 (S-3)	1 (NS)*

\*Extend the wire 1/4" through the solder lug as shown in the upper inset.

( ) Refer to Detail 4-5F and bend a 4" length of large bare wire. Use the illustration as a template to form the wire.

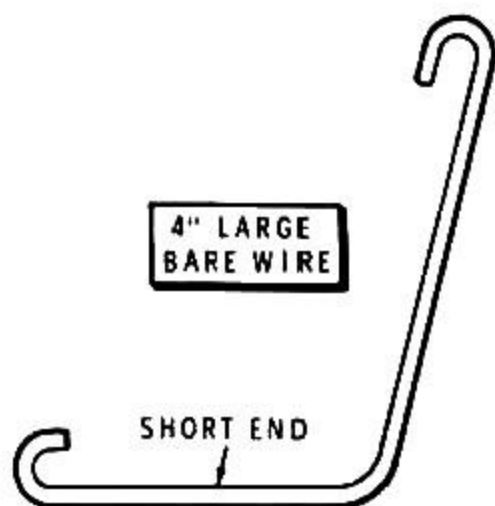

Detail 4-5F

( ) Refer to Detail 4-5G and hook the short end of the bare wire around the switch wire at lug 4 of the 80/20 plate coil. Position the wire as shown. Then crimp and solder the hook to the wire.

Refer to Detail 4-5H Part 1 (fold-out from Page 35) for the following numbered steps.

( ) 1. Close the end of the spade lug with a pair of pliers as shown in inset drawing # 1.

( ) 2. Loosen the 10-32 nut on the 840 pF variable capacitor (#26-145) at screw DP. Position the spade lug as shown and mount the lug on the screw. Retighten the nut.

( ) 3. Refer to inset drawing #2 and bend the spade lug over the edge of the capacitor 90° as shown.

( ) 4. Mount the prepared 840 pF variable capacitor on the chassis. Use 6-32 x 3/8" hardware at BB. Use a cable clamp and 6-32 x 3/8" hardware at G. You will loosen the cable clamp later to install a coaxial cable.

( ) Refer to Detail 4-5H Part 2 and hook the remaining end of the 4" large bare wire around the spade lug on the variable capacitor at DP. Crimp and solder the connection. Make sure the wire is positioned away from the capacitor body and any adjacent wiring.

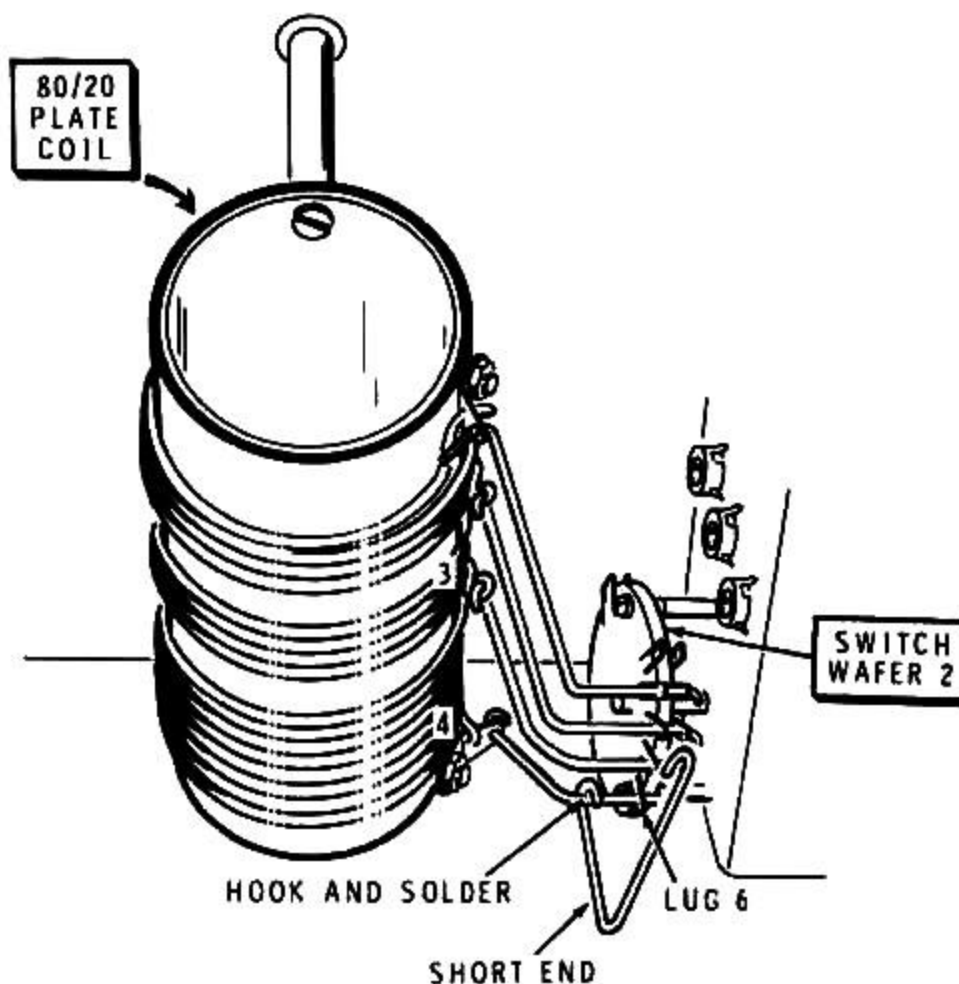

Detail 4-5G

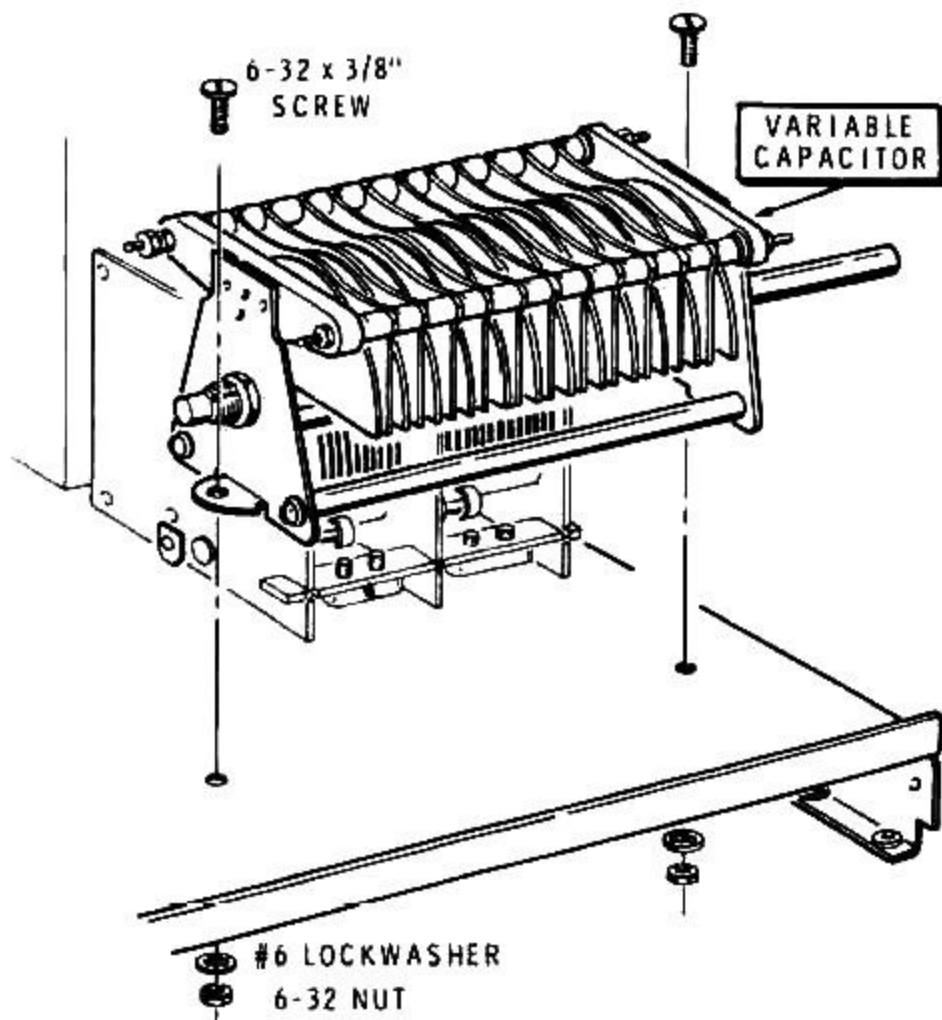

Detail 4-5J

- ( ) Refer to Detail 4-5J and mount variable capacitor #26-131 at holes BA. Use 6-32 x 3/8" hardware.
- ( ) Refer to Detail 4-5K and install the plate coil bracket (#204-2102) on the rear of variable capacitor BA. Use the two extra nuts and lockwashers supplied with the capacitor. Be sure to position the bracket with hole DA as shown.

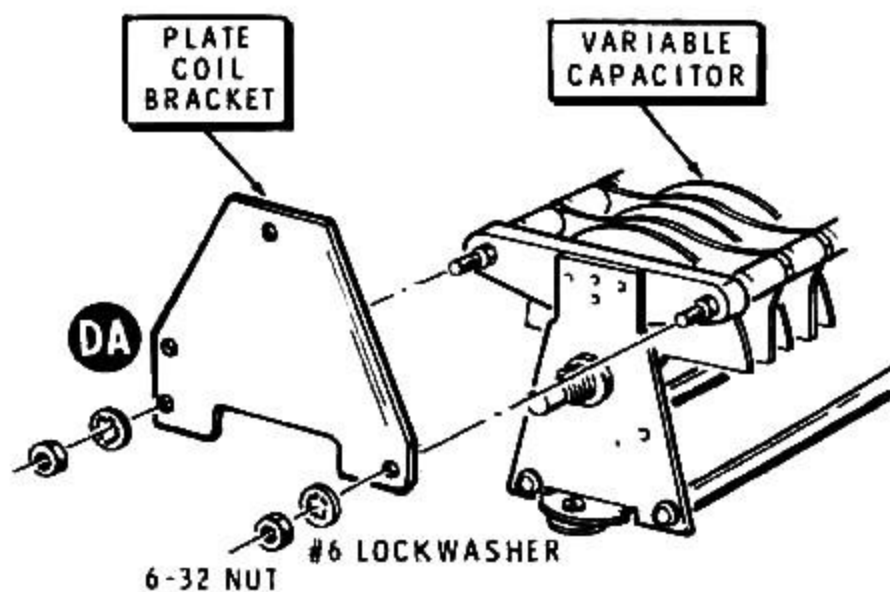

Detail 4-5K

Refer to Detail 4-5L for the following steps.

- ( ) Position the 15/10 plate coil (#40-968) with the silver plated strip located as shown.

- ( ) Place the open end of the coil tubing over the wire projecting from lug 1 of the 80/20 plate coil. Form the solder lug so the coil tubing will butt snugly against it.
- ( ) Connect the tab on the coil to hole DA in the plate coil bracket. Use 6-32 x 1/4" hardware.
- ( ) Solder the coil tubing and the wire lead from the switch wafer to lug 1 of the 80/20 plate coil. Make sure the end of the tubing is against the solder lug and that this connection is well soldered.
- ( ) Connect the free end of the silver plated strip to lug 2 of wafer 2 of switch CZ. Flex the end of the strip and place it between the switch lugs as shown in the inset drawing of the Detail (S-2).

Refer to Detail 4-5M for the following steps.

- ( ) Install a #6 solder lug on one end of a .001  $\mu$ F capacitor (#21-165). Use a 6-32 x 3/16" screw.
- ( ) Mount this capacitor at DB on the plate coil bracket. Use a 6-32 x 3/16" screw and a #6 lockwasher. Before tightening the screw, position the solder lug as shown.
- ( ) Refer to Detail 4-5N and mount an RF choke (#45-61) at CA on the RF shield. Use a 1-3/8" spacer (8-32), two 1/2" flat washers, a #6 lockwasher, a #6 fiber flat washer, and 6-32 x 2" flat head screw. Do not overtighten the screw as the threads in the ceramic choke form can be damaged. Position the choke so solder lug DC points toward spacer DD.

Refer to the Pictorial for the next two steps.

- ( ) Connect a 1-1/2" small bare wire from the solder lug on capacitor CM (S-1) to RF choke solder lug DC (NS).
- ( ) Cut each lead of RF choke #45-6 to a length of 3/8". Connect one lead to choke lug DC (S-2) and the other lead to solder lug DD (S-1).

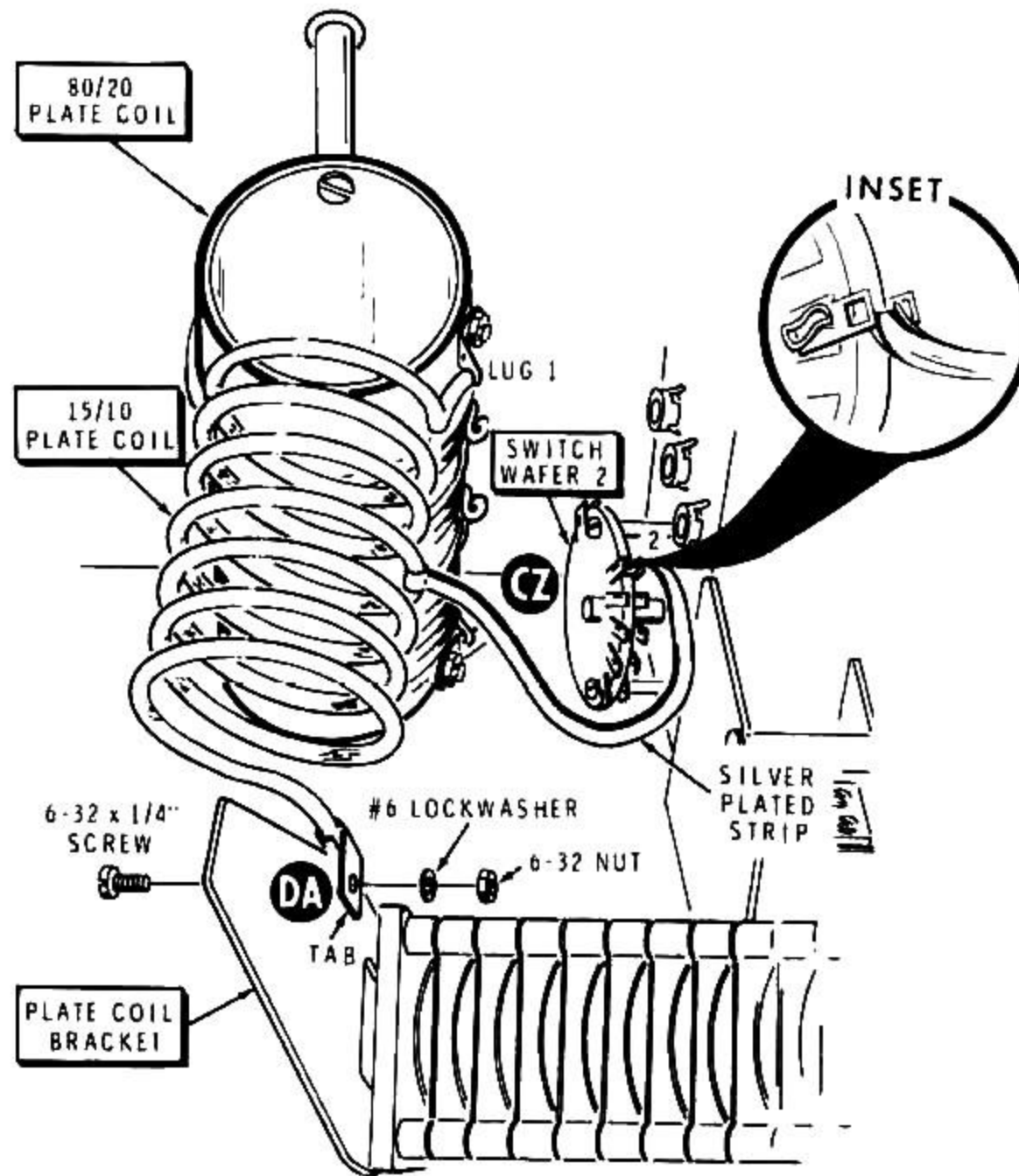

Detail 4-5L

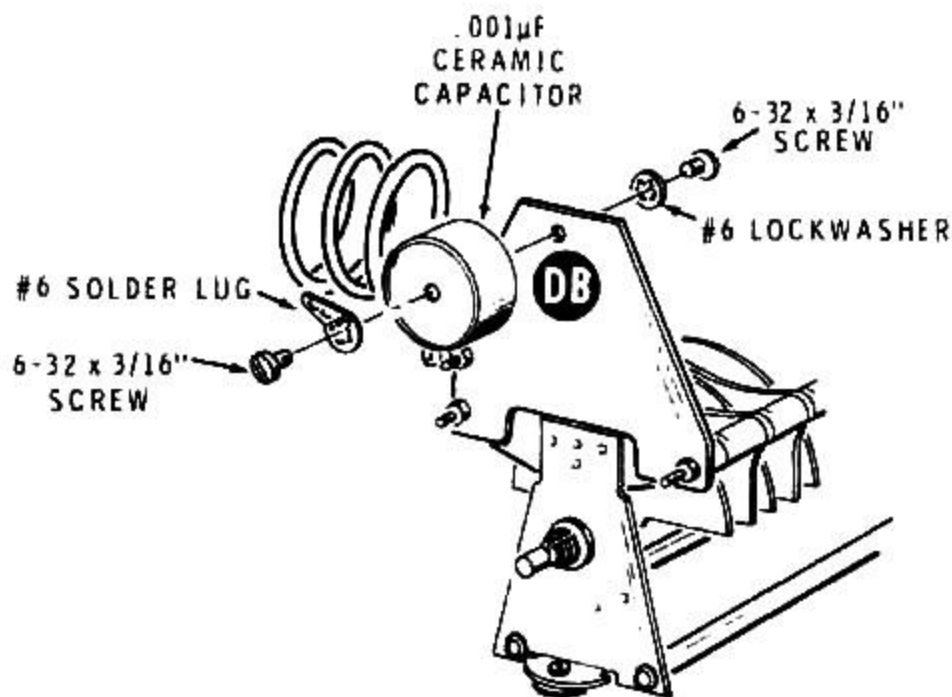

Detail 4-5M

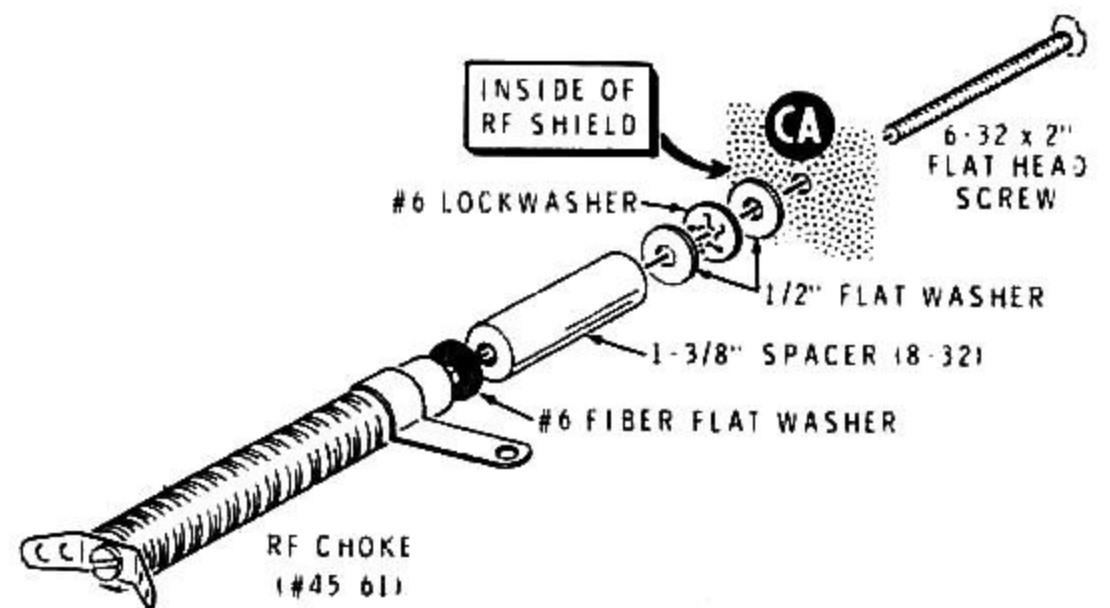

Detail 4-5N

# PART 2

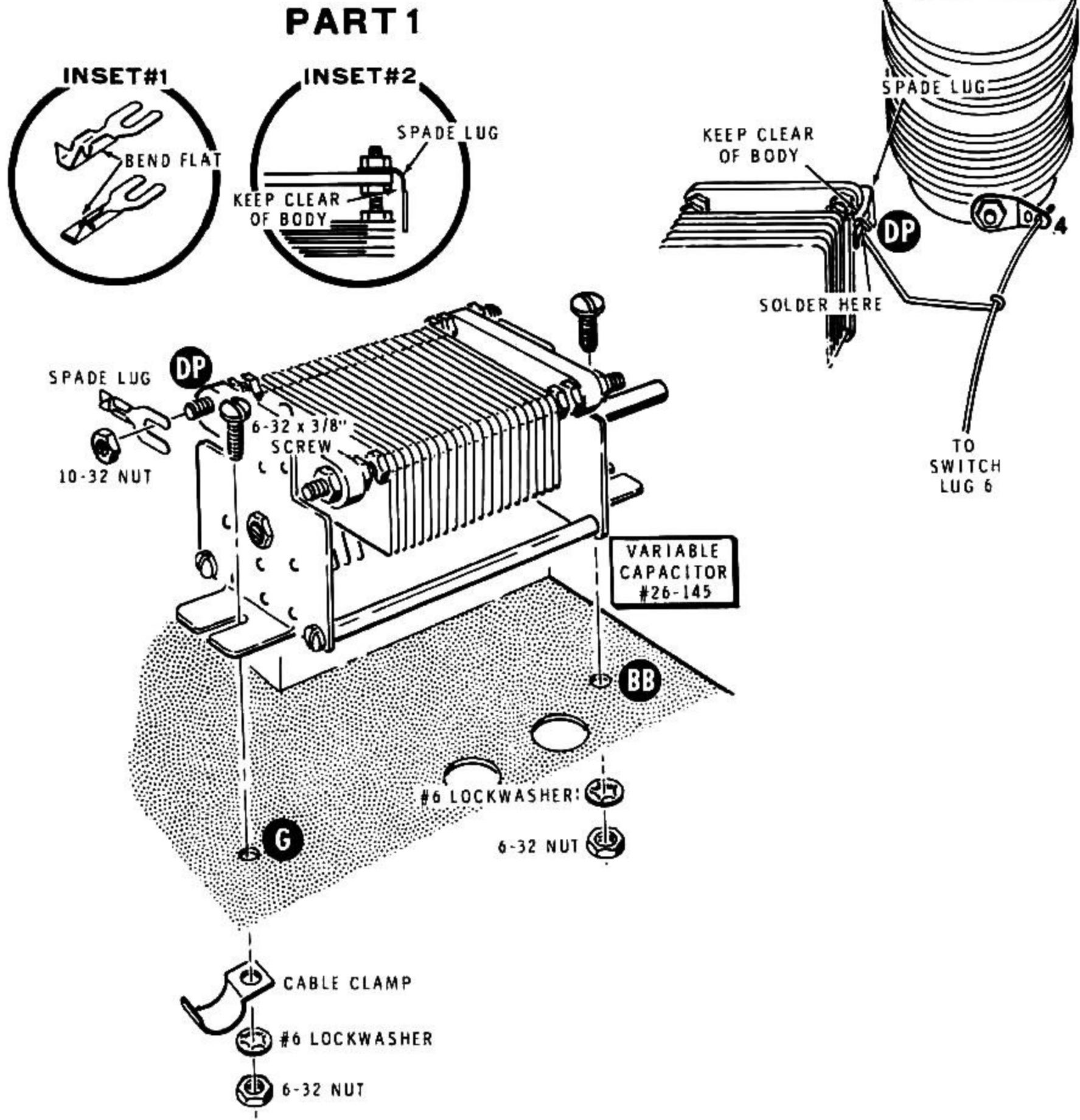

**Detail 4-5H**

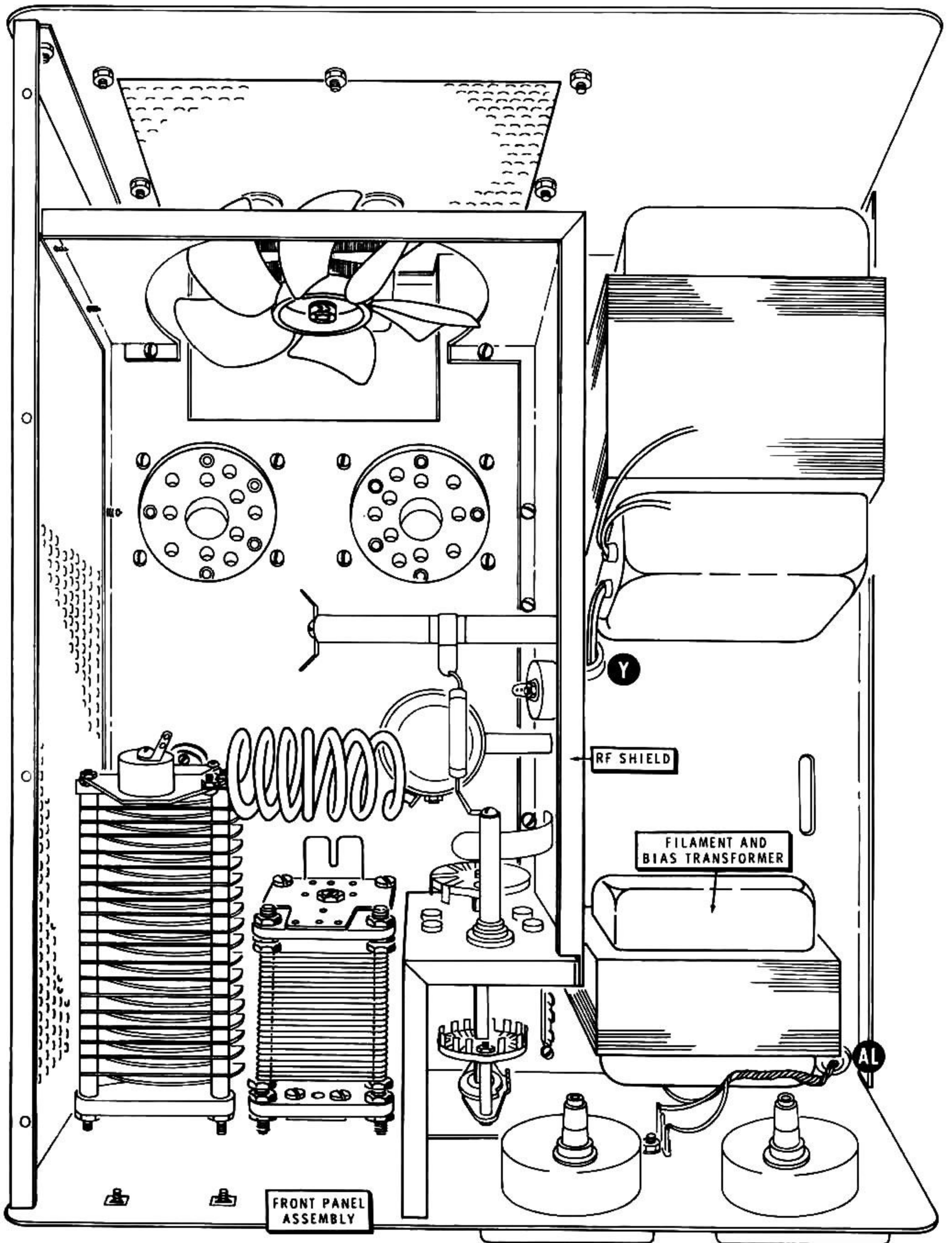

**PICTORIAL 4-6**

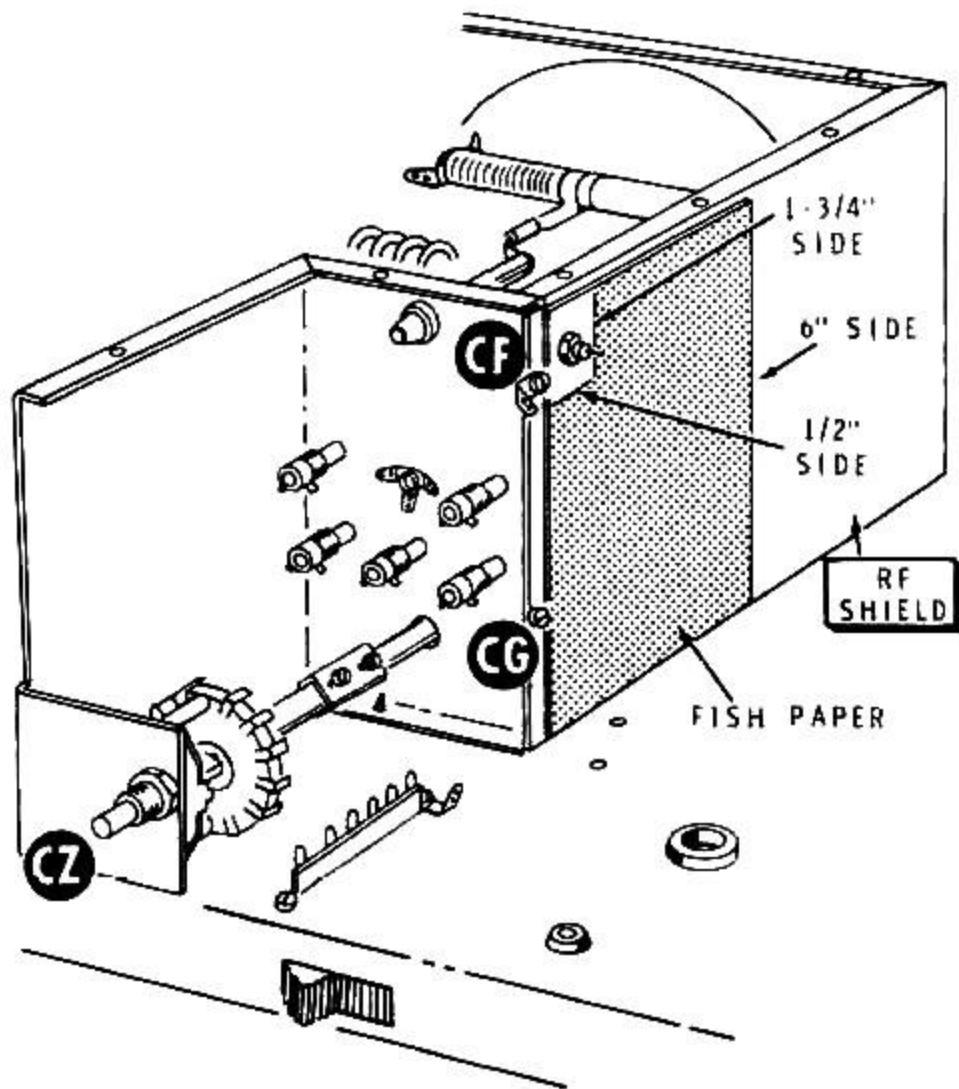

Detail 4-6A

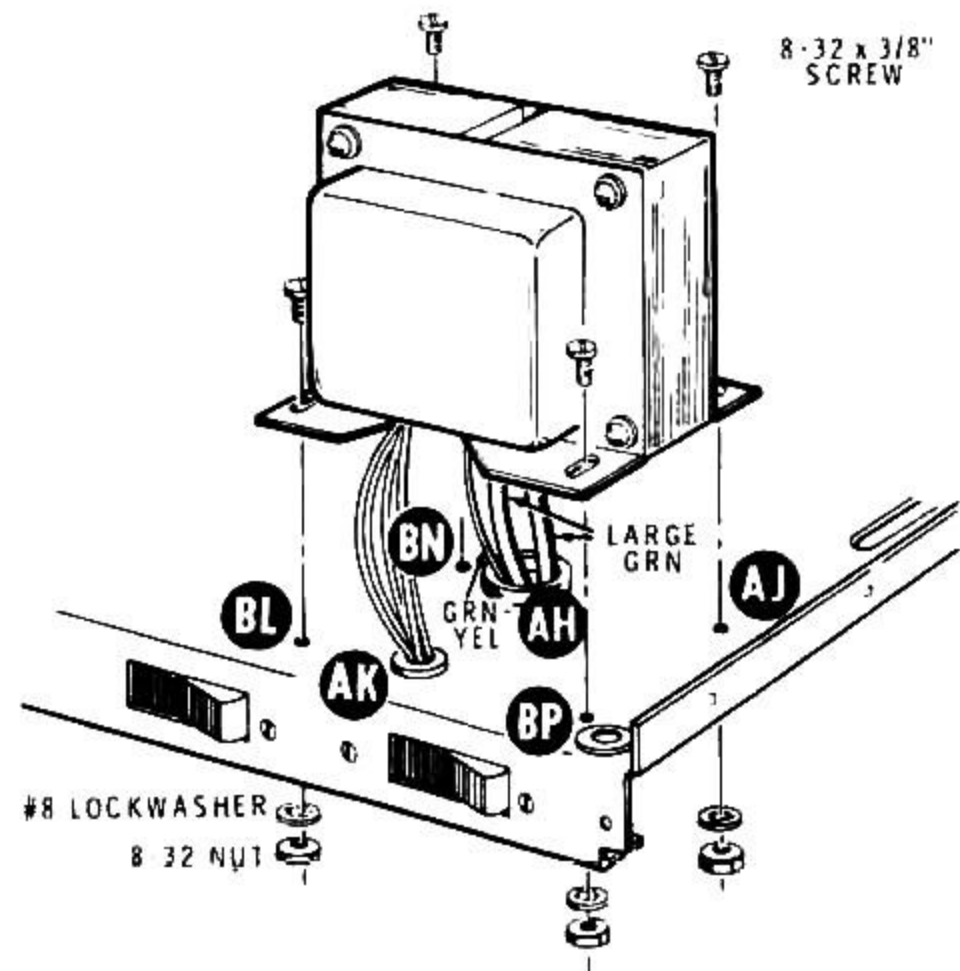

Detail 4-6B

Refer to Pictorial 4-6 (fold-out from Page 36) for the following steps.

- ( ) Refer to Detail 4-6A and notch out one corner of the 4-1/2" x 6" fish paper insulator as shown. Make sure the 1-3/4" side of the notch is along the 6" side of the fish paper.
- ( ) Position the fish paper with the 6" side vertical and with the adhesive side against the RF shield. Make sure the fish paper clears the zener diode and the sheet metal screw at CG. Rub the paper firmly into place.
- ( ) Refer to Detail 4-6B and mount the filament and bias transformer (#54-238) on the top of the chassis. As you position the transformer, insert the two large green leads and the green-yellow lead down through grommet AH. Insert the other leads through grommet AK. Use 8-32 x 3/8" hardware at AJ, BL, BN, and BP. Push the transformer toward the front of the chassis as far as possible before you tighten the hardware.
- ( ) Temporarily remove the control nut and the control flat washer from rotary switch CZ. (Detail 4-6A).



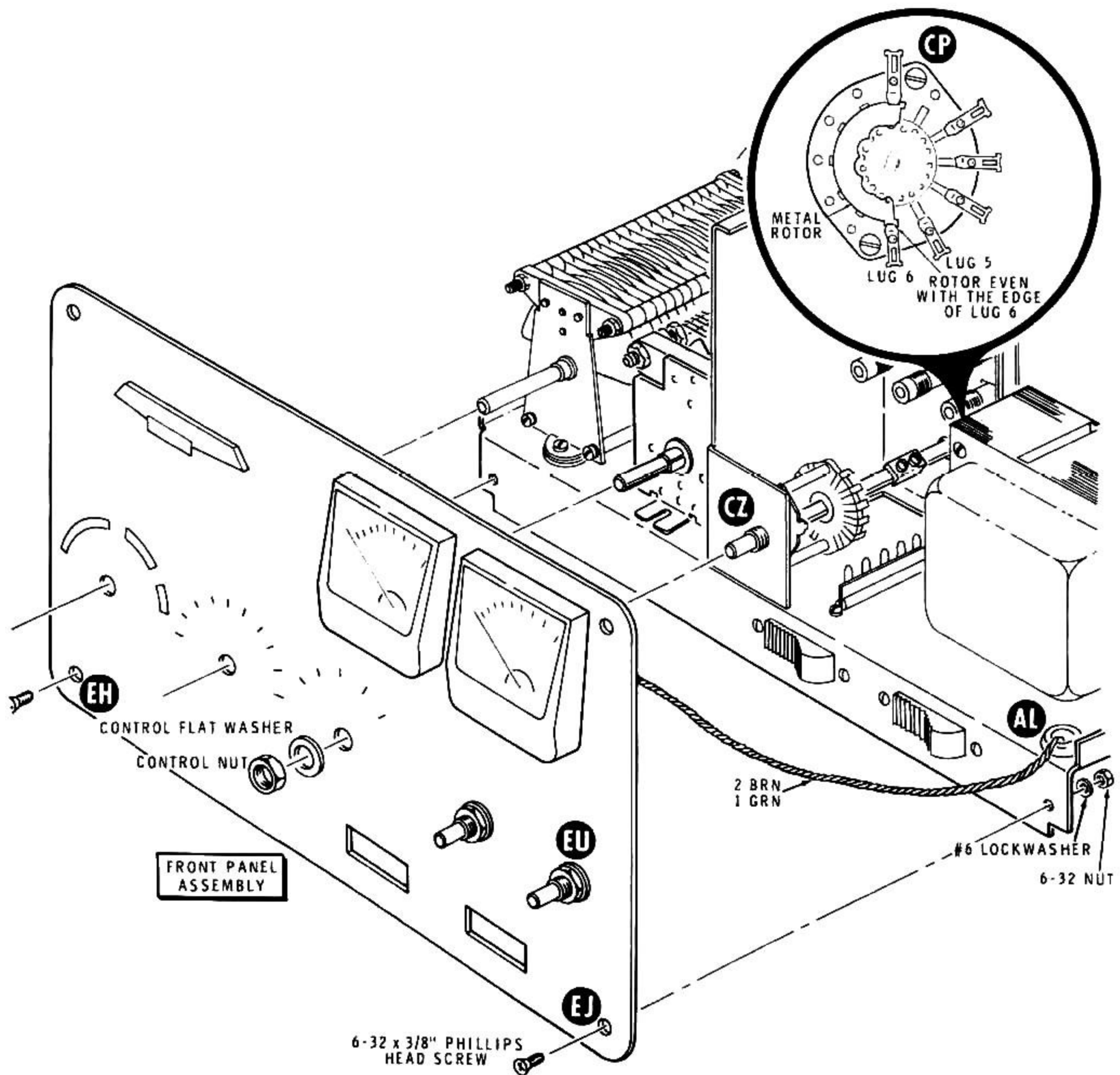

Detail 4-6C

( ) Refer to Detail 4-6C and mount the front panel assembly on the front of the chassis. Insert the twisted hookup wires (two brown and one green) down through grommet AL. Use 6-32 x 3/8" phillips head hardware at EH and EJ.

( ) Replace the control flat washer and the control nut on switch CZ. Refer to the inset drawing and check the metal rotor of switch wafer CP again. If the metal rotor extends past lug 6, arcing can occur between the rotor and lug 5.

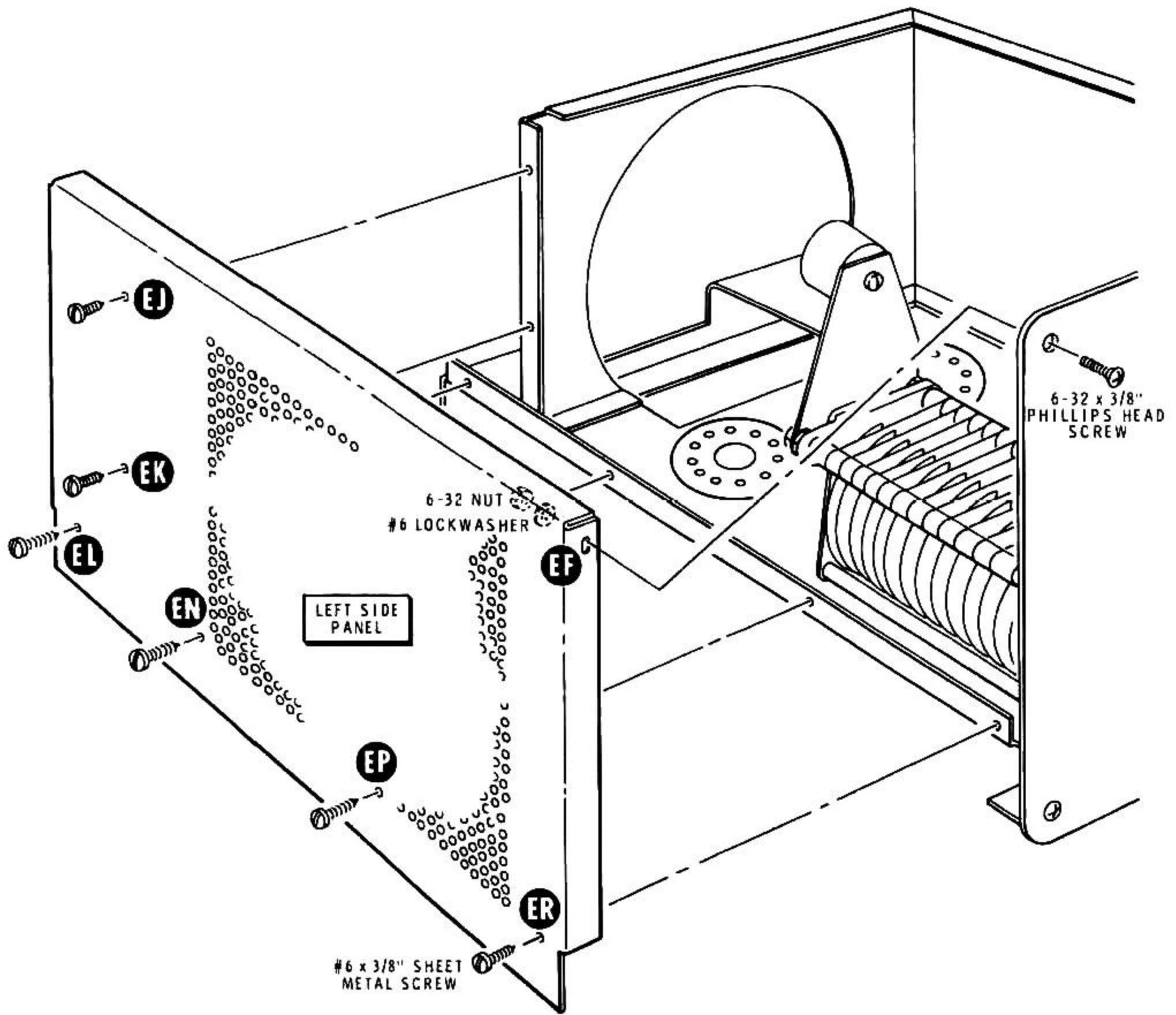

Detail 4-6D

- ( ) Adjust the position of the filament and bias transformer to insure approximately 1/16" clearance between the transformer end bell and any connections to the lugs of switch EU.
- ( ) Refer to Detail 4-6D and install the left side panel (#203-646). Use 6-32 x 3/8" phillips hardware at EF. Use #6 x 3/8" sheet metal screws at EJ, EK, EL, EN, EP, and ER.

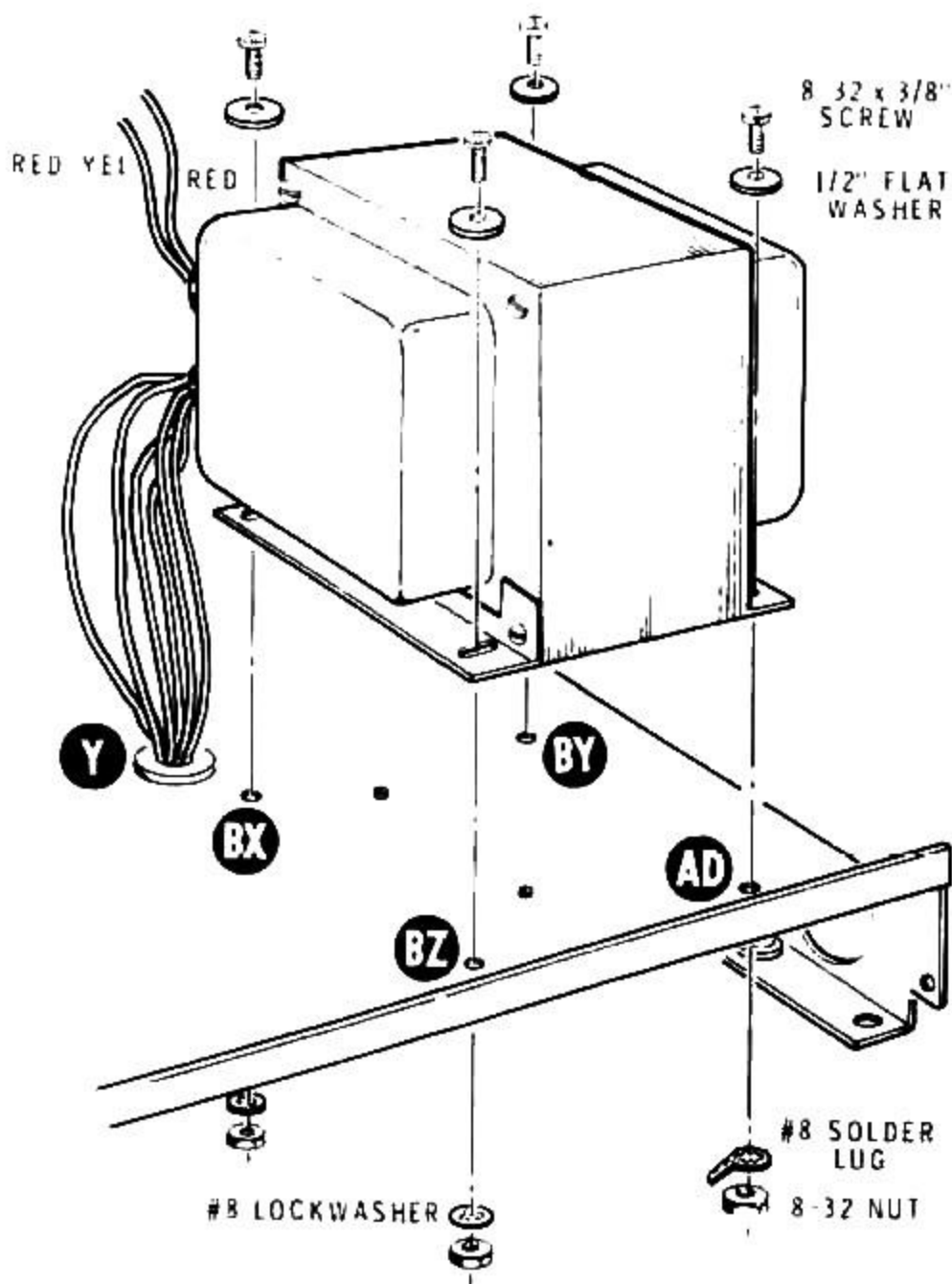

Detail 4-6E

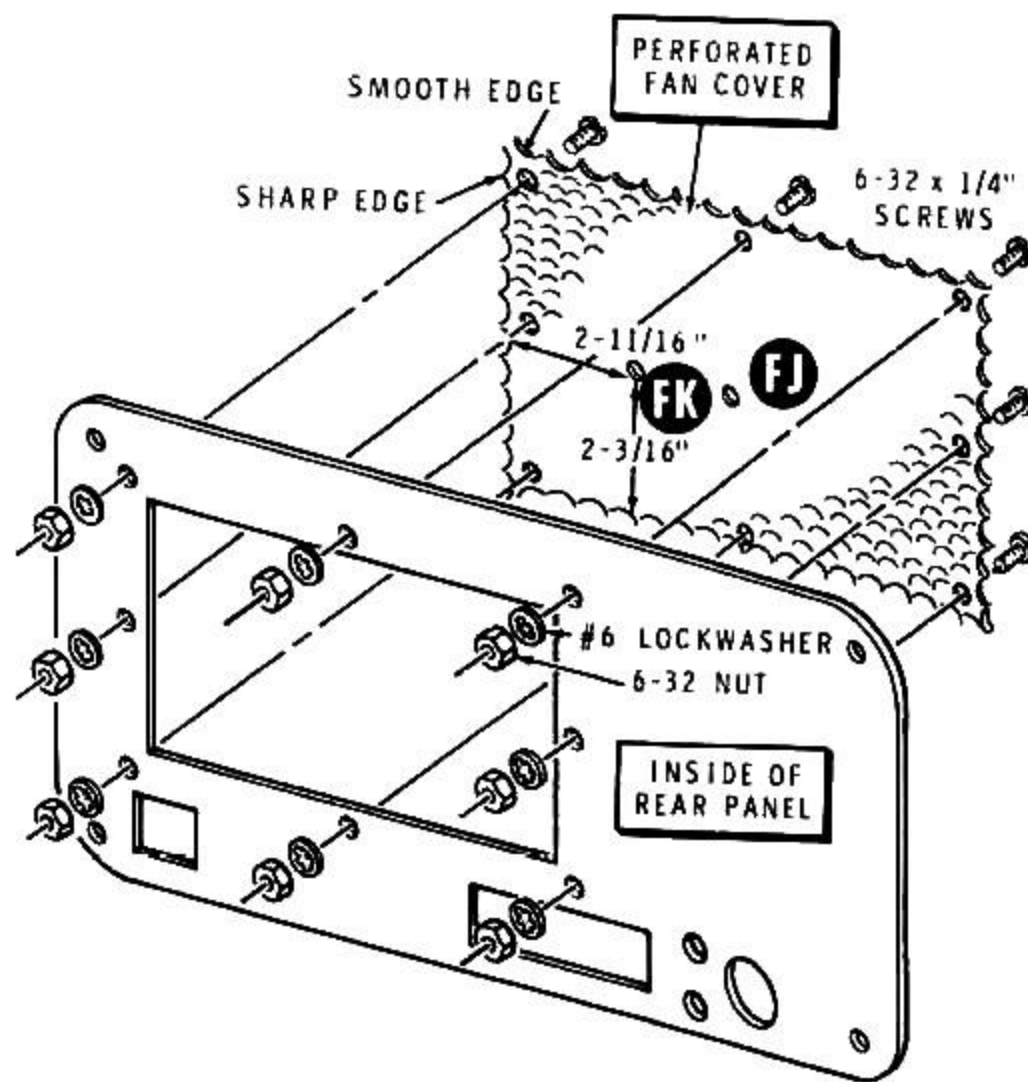

Detail 4-6F

Refer to Detail 4-6G for the following steps.

- ( ) Refer to Detail 4-6E and mount the HV transformer. Position the wires from the end bell so they are above grommet Y. Insert all leads except the red and the red/yellow leads down through grommet Y. Use an 8-32 x 3/8" screw, a 1/2" flat washer, a #8 solder lug and an 8-32 nut at AD. At BX, BY and BZ, use 8-32 x 3/8" hardware with a 1/2" flat washer at each location. Before you tighten the hardware, make sure the transformer end bell does not protrude beyond the chassis rear apron.
- ( ) Refer to Detail 4-6F and locate the perforated fan cover (#205-874) and the rear panel (#203-644). The edges of the fan cover are smooth on one side and sharp on the other. Before placing the sharp edge against the rear panel, check the two off-center holes (FK and FJ) which, if viewed as shown in the Detail, must be closest to the bottom left-hand corner.
- ( ) Fasten the perforated fan cover to the rear panel with 6-32 hardware. The sharp edge of the fan cover should be turned toward the rear panel.

- ( ) 1. Position the motor as shown. Then move one of the motor leads to the indicated hole in the plastic frame (away from the motor shaft).
- ( ) 2. Similarly, move the other motor lead to the indicated hole in the plastic frame.
- ( ) 3. Carefully remove the mounting hardware from one side of the motor as shown. Discard the screw and the lockwasher.

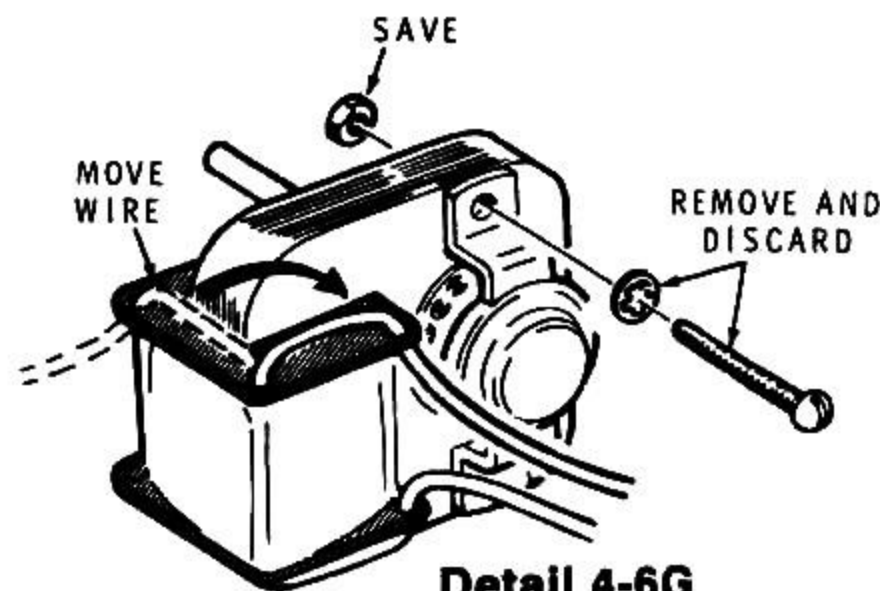

Detail 4-6G

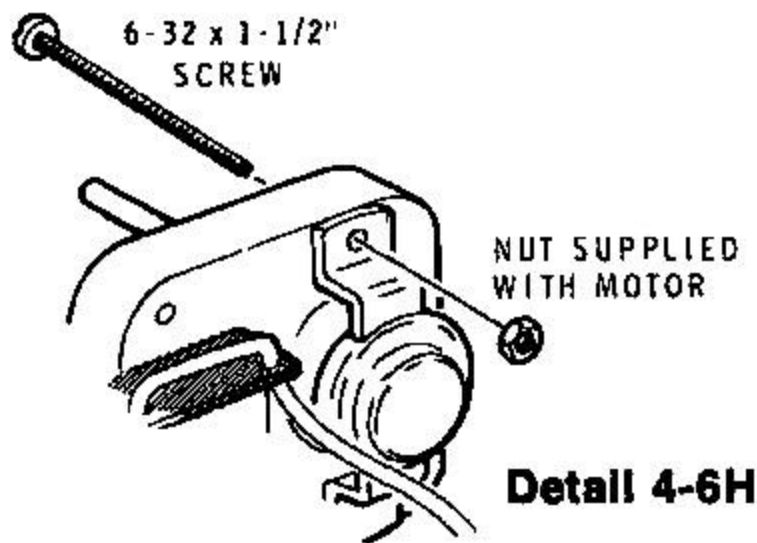

**Detail 4-6H**

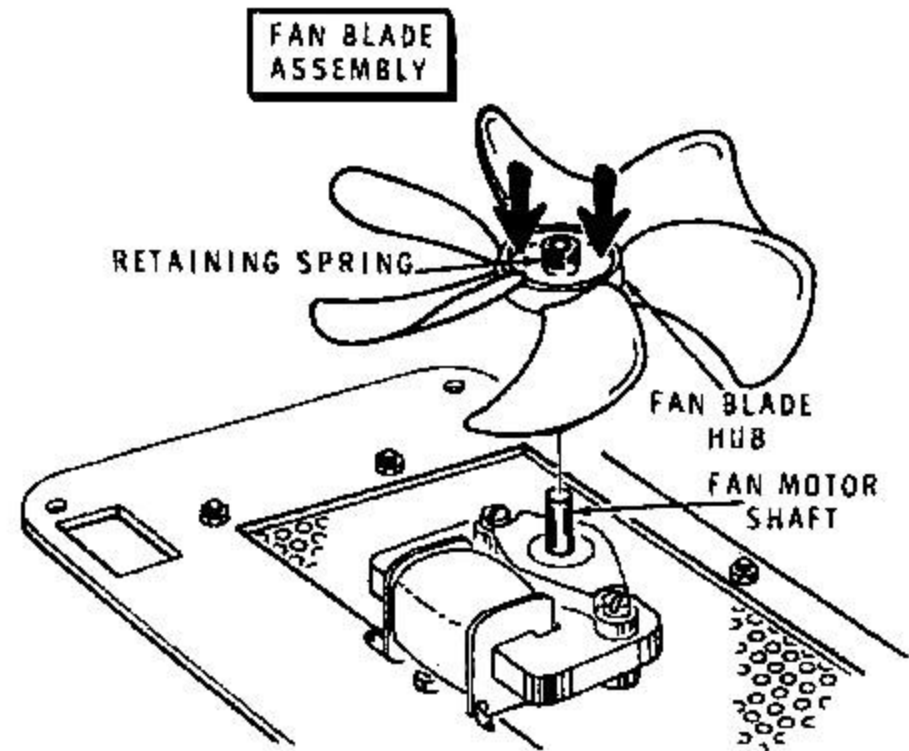

**Detail 4-6K**

- ( ) Refer to Detail 4-6H and, from the shaft side of the motor, insert the 6-32 x 1-1/2" screw (supplied with the motor assembly) through the mounting hole. Then secure the screw with the nut you removed in step 3 above.
- ( ) Similarly modify the hardware on the other side of the motor. Be sure to install the new screw from the shaft side of the motor.
- ( ) Refer to Detail 4-6J and mount the fan motor on the perforated fan cover at holes FJ and FK. Use two 7/16" spacers, four #6 flat metal washers, and two 6-32 nuts as shown.

- ( ) Refer to Detail 4-6K and install the fan blade assembly (# 266-296) on the fan motor shaft. Position the fan motor and the blade assembly as shown, and apply firm downward pressure with both thumbs on the fan blade hub. A slight rocking motion will help. Push the fan blades onto the motor shaft until there is 1/16" to 1/32" clearance between the fan blade hub and the motor frame.
- ( ) Refer to Detail 4-6L and mount the rear panel to the chassis rear apron at FC and FD, and to the left side panel at FB. Use 6-32 x 3/8" hardware.

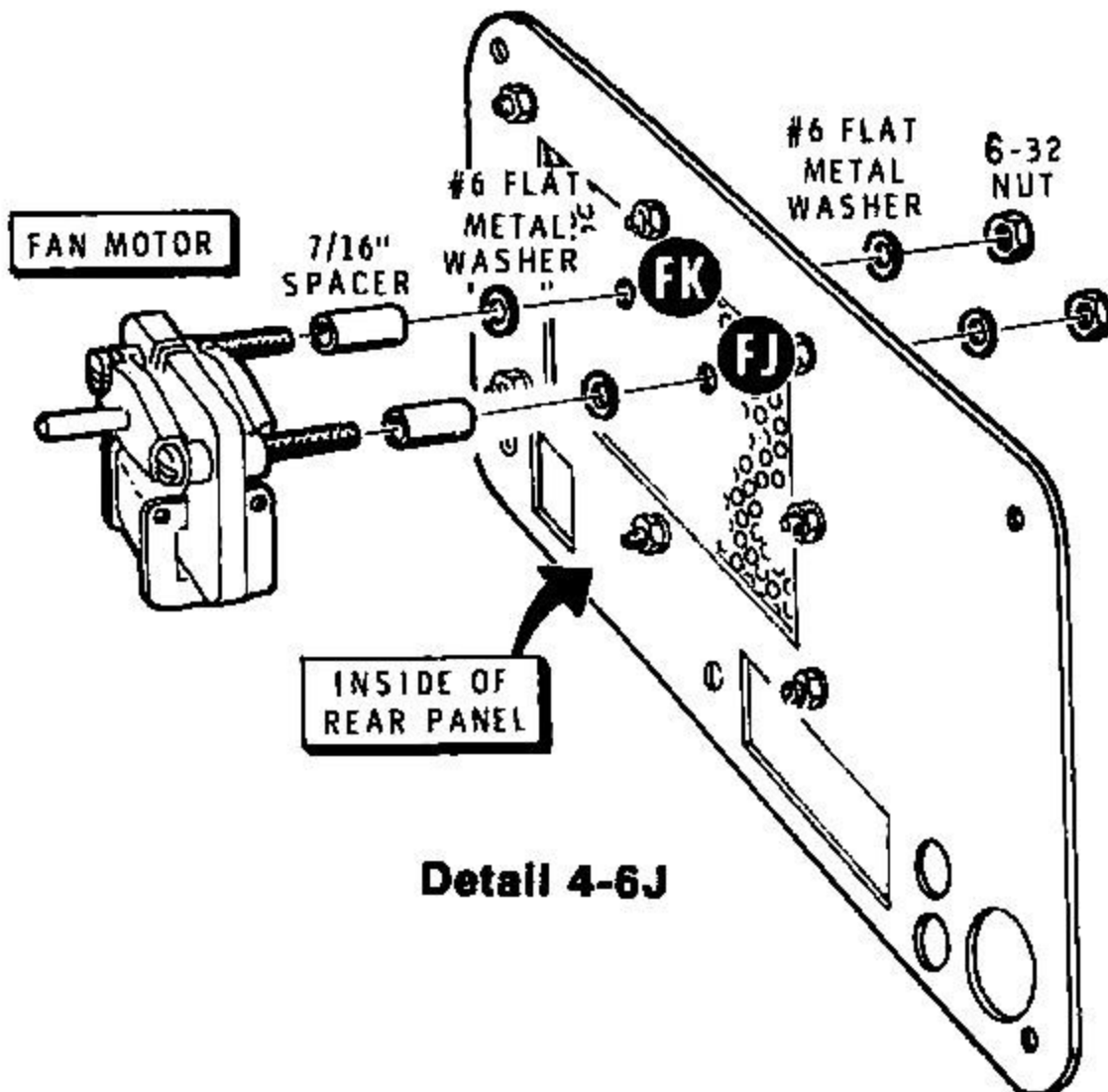

**Detail 4-6J**

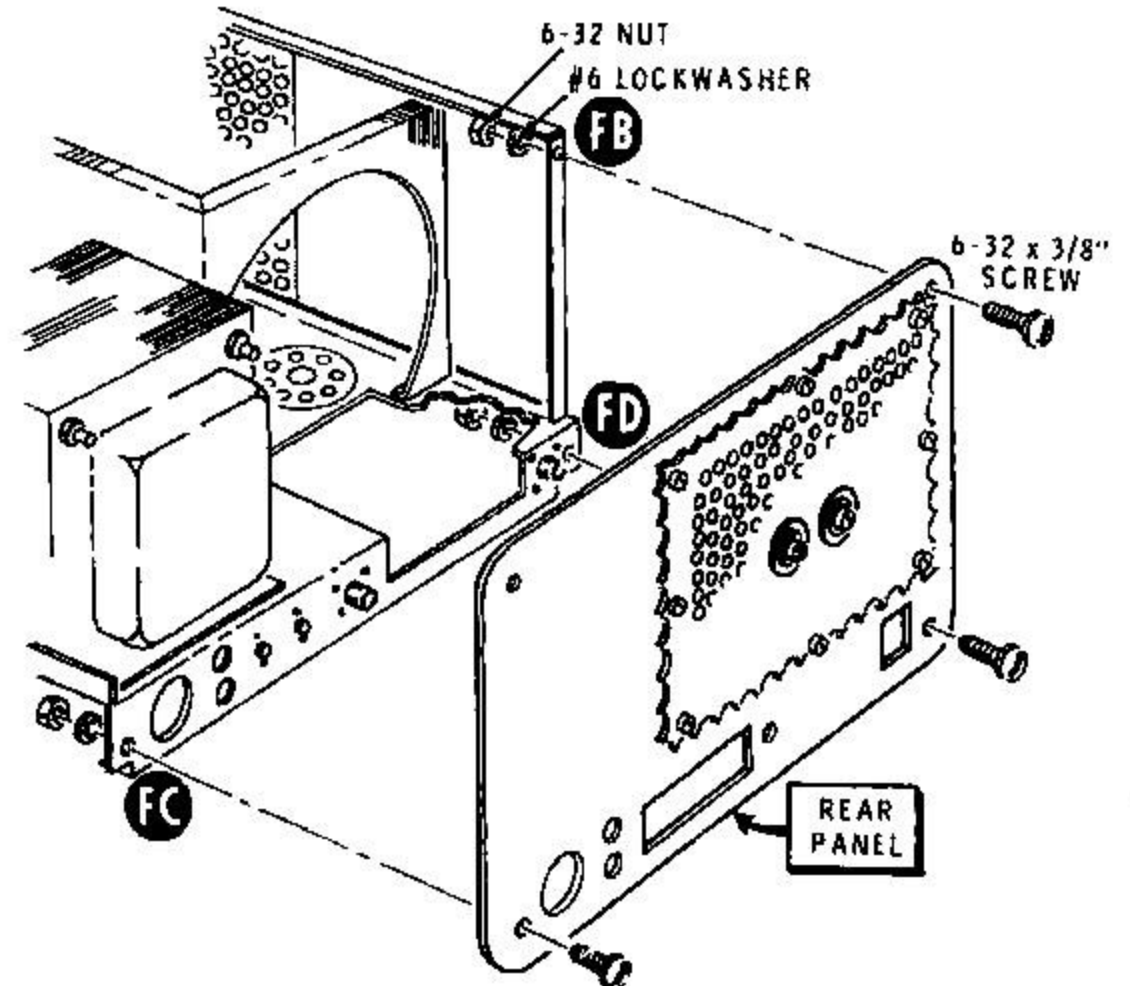

**Detail 4-6L**

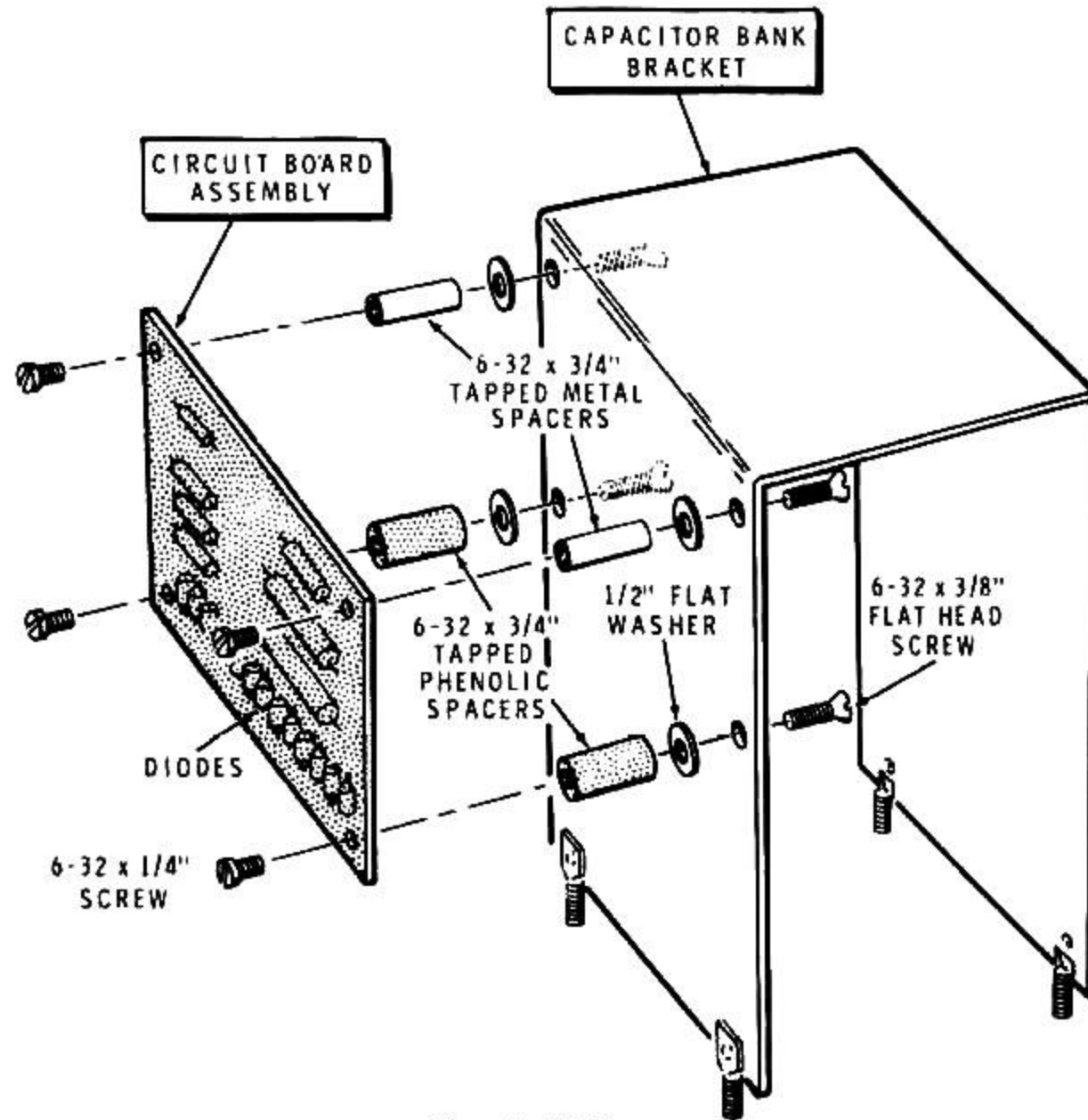

Detail 4-7A

Refer to Pictorial 4-7 (fold-out from Page 43) for the following steps.

- ( ) Refer to Detail 4-7A and mount the circuit board assembly on the capacitor bank bracket. Use 6-32 x 1/4" screws, 6-32 x 3/4" tapped metal spacers, 6-32 x 3/4" tapped phenolic spacers, 1/2" flat washers, and 6-32 x 3/8" flat head screws. Note that the diodes, and the phenolic spacers, are along the lower edge of the circuit board.
- ( ) Refer to Detail 4-7B and mount the capacitor bank bracket with one spade bolt entering each of holes BR, BS, BT, and BU. Use #6 lockwashers and 6-32 nuts only on spade bolts BR, BS, and BU. Leave the nuts flush with the ends of the spade bolts.
- ( ) Mount a 5-lug terminal strip (#431-42) on spade bolt BT. Use two #6 lockwashers and a 6-32 nut. Leave the face of the nut flush with the end of the spade bolt.

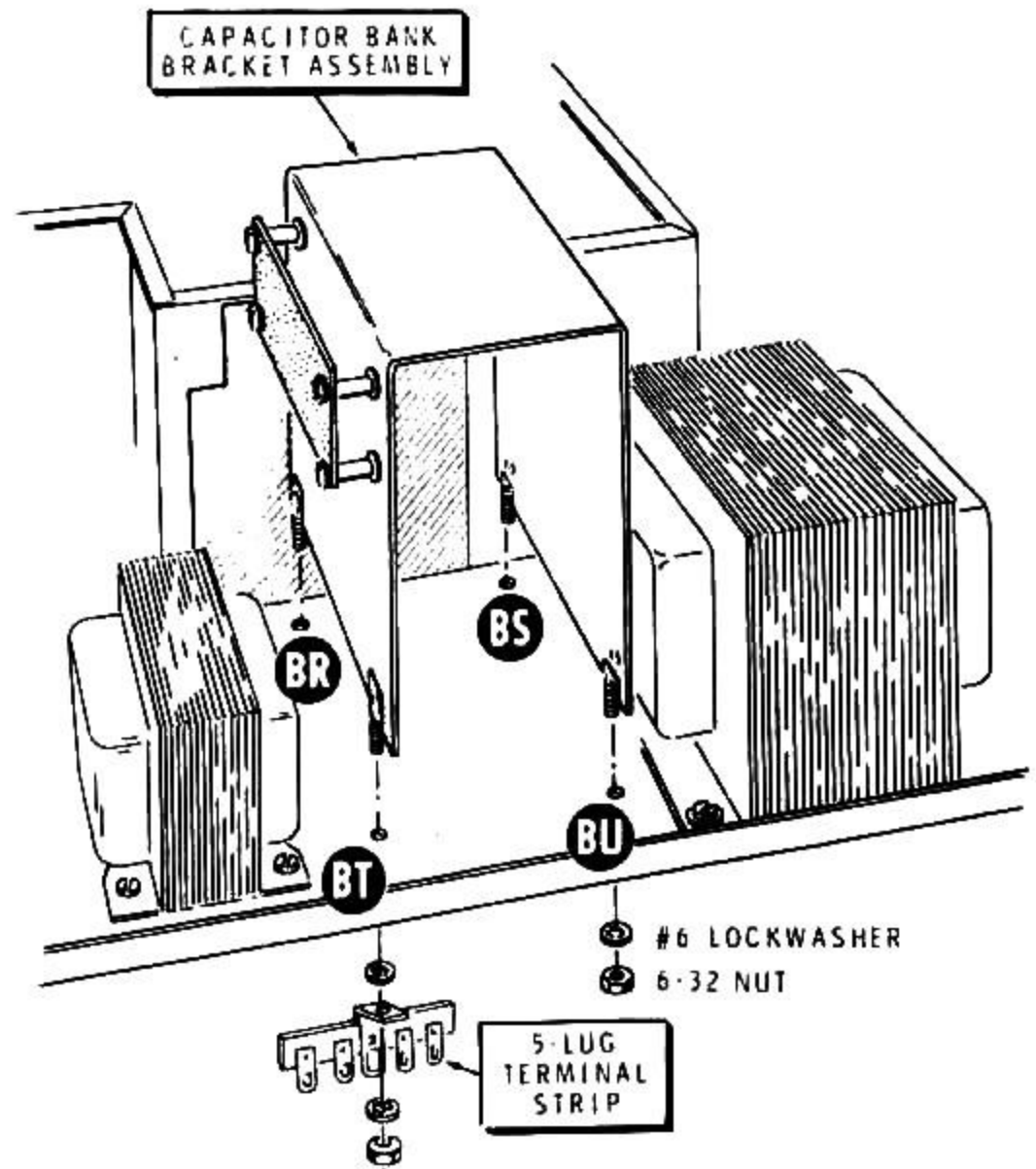

Detail 4-7B

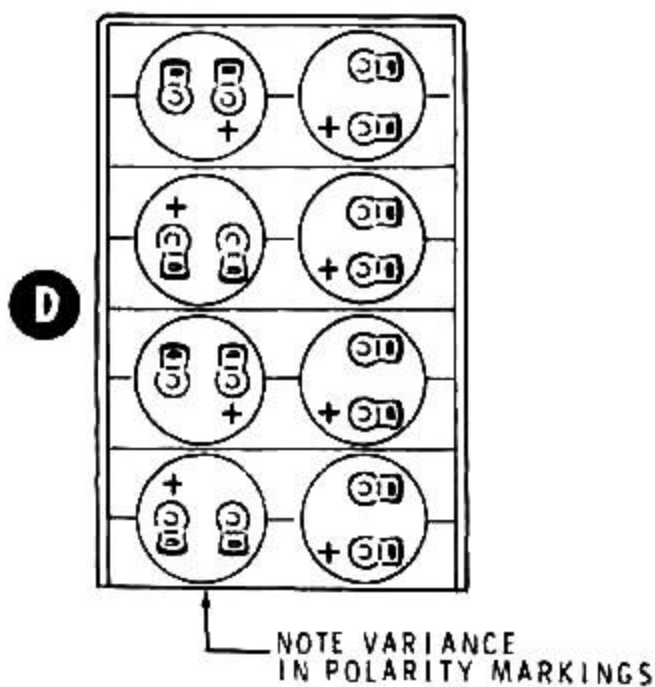
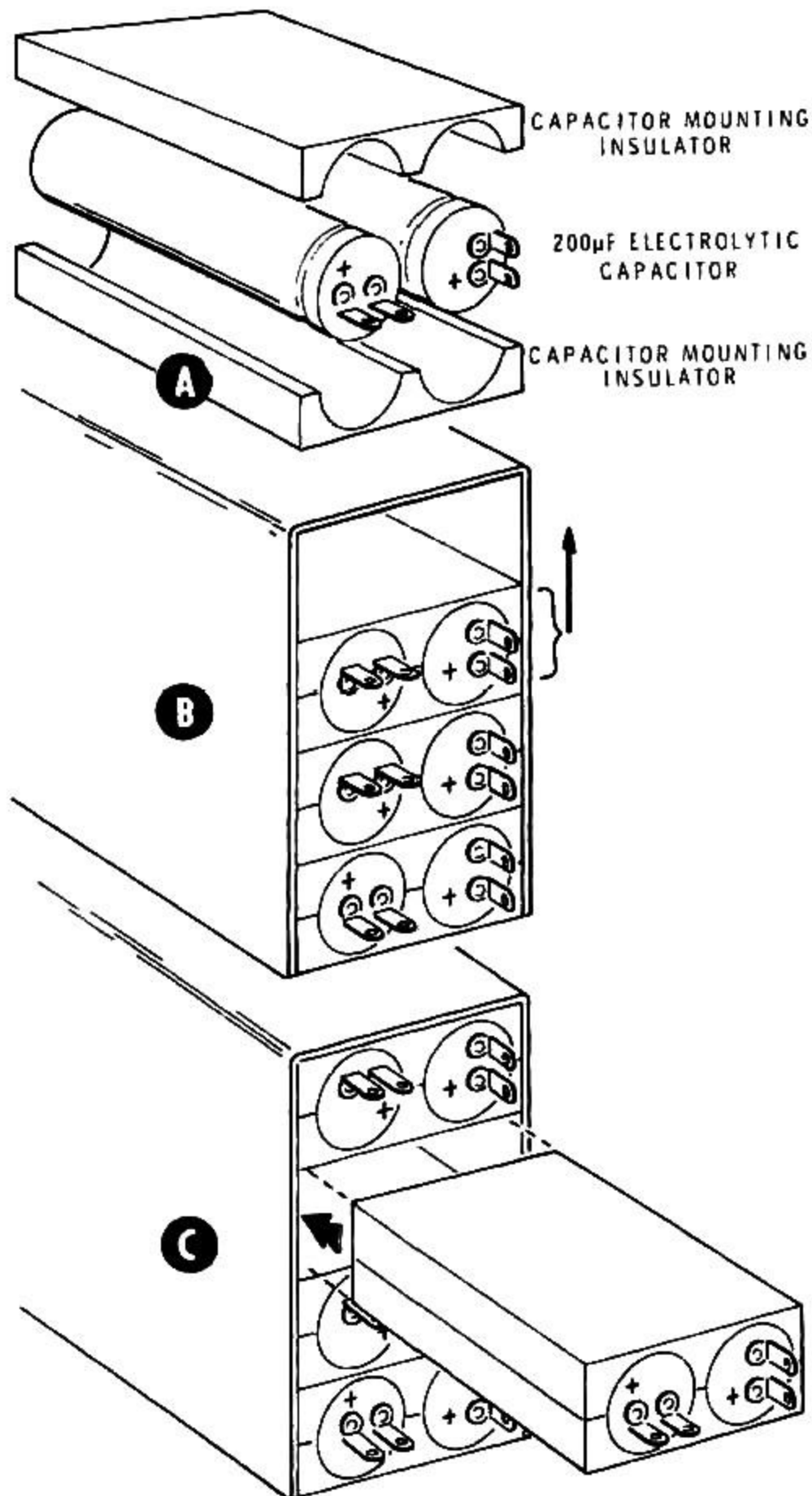

Detail 4-7C

Refer to Detail 4-7C for the steps covering the capacitor bank assembly.

- ( ) **Part A:** Assemble four capacitor sections, each composed of two capacitor mounting insulators (#75-125) and two 200  $\mu$ F electrolytic capacitors (#25-224).
- ( ) **Part B:** Stack three capacitor sections in the capacitor bank bracket. Then lift up the top section to the top of the bracket.
- ( ) **Part C:** Insert the fourth capacitor section into the vacated space in the bracket.
- ( ) **Part D:** Align the capacitor lugs and the positive (+ or red dot) polarity markings as shown. Then push the capacitors snugly against the fish paper and tighten the spade bolt nuts on the bottom of the chassis just to the point where you can no longer rotate the capacitors with your fingers. Do not overtighten. Note the position of the terminal strip mounting foot in Detail 4-7B.



Detail 4-7D

- ( ) Refer to Detail 4-7D and cut four pieces of small bare wire 1-5/8" long and one piece 1-3/8" long. Bend down 1/8" at one end of each. These wires will be used in the capacitor bank wiring.
- ( ) Cut four pieces of small black sleeving 3/4" long for use in wiring the capacitor bank.

