

This Manual is provided by
CBTricks.com

Someone who wanted to help you repair your equipment put together this information.

SBE Catalina III Service Manual

If you would like to help us put more manuals online support us.

If you would like to help with this project let us know.

Supporters of CBTricks.com paid for the hosting so you would have this file.

CBTricks.com is a non-commercial personal website was created to help promote the exchange of service, modification, technically oriented information, and historical information aimed at the Citizens Band, GMRS (CB "A" Band), MURS, Amateur Radios and RF Amps.

CBTricks.com is not sponsored by or connected to any Retailer, Radio, Antenna Manufacturer or Amp Manufacturer, or affiliated with any site links shown in the links database. The use of product or company names on my web site is not endorsement of that product or company.

If your company would like to provide technical information to be featured on this site I will put up on the site as long as I can do it in a non-commercial way.

The site is supported with donation from users, friends and selling of the Galaxy Service Manual CD to cover some of the costs of having this website on the Internet instead of relying on banner ads, pop-up ads, commercial links, etc. Thus I do not accept advertising banners or pop-up/pop-under advertising or other marketing/sales links or gimmicks on my website.

ALL the money from donations is used for CBTricks.com I didn't do all the work to make money (I have a day job). This work was not done for someone else to make money also, for example the ebay CD sellers.

All Trademarks, Logos, and Brand Names are the property of their respective owners.

This information is not provided by, or affiliated in any way with any radio or antenna Manufacturers.

Thank you for any support you can give.

Catalina III

MODEL SBE-29CB

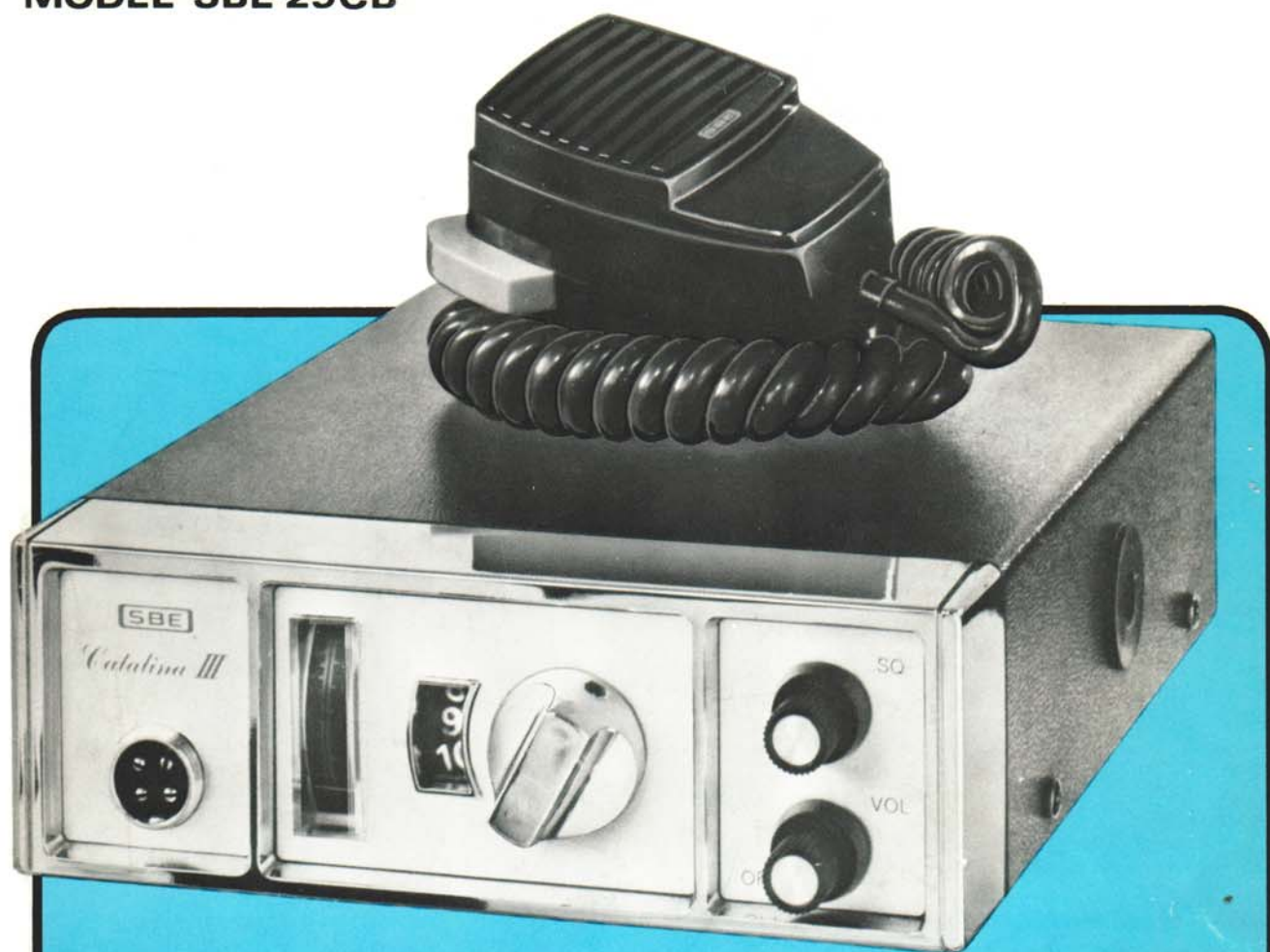

SERVICE MANUAL

SBE®

TABLE OF CONTENTS

1. GENERAL

- 1.1 Customer Service 1
- 1.2 Parts Orders 1
- 1.3 Factory Returns 1

2. SPECIFICATIONS

- 2.1 General 2
- 2.2 Receiver 2
- 2.3 Transmitter 3

3. INSTALLATION

- 3.1 Installation 4
- 3.2 Antenna Tuning 5
- 3.3 Final Check 5
- 3.4 Noise Suppression 5

4. CIRCUIT DESCRIPTION

- 4.1 Introduction 6
- 4.2 Receiver 6
- 4.3 Transmitter 8

5. SERVICING

- 5.1 Introduction 10
- 5.2 Test Signals 10
- 5.3 Troubleshooting 11

6. PARTS LIST 22

BACK POCKET:

SCHEMATIC DIAGRAM
SERVICE BULLETINS

ILLUSTRATIONS

- 4-1 SBE-29CB Transceiver Block Diagram 9
- 5-1 Performance Verification Procedure 12
- 5-2 Recommended Test Instruments 13
- 5-3 SBE-29CB Synthesizer Mixing Scheme 14
- 5-4 Transmitter Test Connection 15
- 5-5 Receiver Test Connection 15
- 5-6 Receiver Alignment Procedure 16
- 5-7 AGC Voltages versus RF Input Level 16
- 5-8 Alignment Layout 17
- 5-9 Receiver Injection Voltages 17
- 5-10 Transmitter Alignment Procedure 18
- 5-11 Transmitter Alignment Waveforms 19
- 5-12 Modulation Waveforms 20
- 5-13 Component Layout 21

SUBJECT

NUMBER

| SUBJECT | NUMBER |
|---------|--------|
| | |

SECTION 1 GENERAL

1.1 CUSTOMER SERVICE

The SBE Technical Services Department functions as a source of information on the application, installation and use of SBE products. In addition, the Technical Services Department provides technical consultation on service problems and availability of local and factory repair facilities.

In any communications to the Technical Services Department, please include a complete description of your problems or needs, including model and serial numbers of the unit or units in question, accessories being used, any modifications or attachments in use, or any non-standard installation details.

For assistance on any of the above matters, please contact SBE, Incorporated, Technical Services Department, 220 Airport Boulevard, Watsonville, California 95076. Phone: 408/722-4177.

1.2 PARTS ORDERS

SBE original replacement parts are available from the Factory Parts Department at 1045 Main Street, Watsonville, California 95076.

When ordering parts, please supply the following information:

Model number of the unit.
Serial number of the unit.
Part number.
Description of the part.

1.3 FACTORY RETURNS

Repair services are available locally through SBE Certified Service Stations across the country. A list of these Service Stations is available upon request from the Technical Services Department. Do not return any merchandise to the Factory without authorization from the Factory.

SECTION 2
SPECIFICATIONS

2.1 GENERAL

| | |
|-----------------------------|---|
| Compliance | F.C.C. Type Accepted (Part 95, Class D) |
| Channels | 23 |
| Frequency Range | (26.965 - 27.255) MHz |
| Frequency Control | Crystals, Synthesized |
| Frequency Tolerance | ±0.003% |
| Operating Temperature Range | -30°C to +50°C |
| Humidity | 95% |
| Input Voltage | (11.7 - 15.9) VDC positive or negative ground |
| Microphone | Dynamic |
| Size | Height: 2" (53mm) Width: 6¼" (160mm) Depth: 7-7/8" (200mm) |
| Weight | 3 lbs., 1.36 Kg. |
| Power Consumption | 13.8 VDC Receive (squelched) 0.25 A Receive (2 watts audio) 1.1 A Transmit (3 watts out) 1.5 A |
| Fuse | 2A fast blow (Type 3AG or A.G.C.) |

2.2 RECEIVER

| | |
|--------------------|---------------------------------|
| Sensitivity | 0.7μV for 10db S+N/N |
| Selectivity | -6db @ ±6 KHz, -50db @ ±10 KHz |
| IF Frequency | 10 MHz, 455 KHz |
| AGC Response | Less than 10db for 10-100,000μV |
| Squelch Threshold | Less than 1μV |
| Audio Power Output | 2 watts |

External Speaker (Not Supplied) 4 or 8 Ω . Disables internal speaker when connected.

Squelch Range 200 μ V (Minimum)

2.3 TRANSMITTER

Power Output 4 watts

Modulation 95-100%

Modulator Response 300-2500 Hz

Output Impedance 50 Ω , unbalanced

Emission 6A3

SECTION 3 INSTALLATION

GENERAL

The first step in installation of the mobile transceiver is selection of antenna and transceiver mounting positions.

The selection of an antenna and its mounting position is the most critical factor in determining the end performance of an installation. Generally, the most satisfactory installation position for most vehicles is the center of the passenger compartment roof. As a second choice, the trunk can be a satisfactory antenna mounting point, especially on those cars where the trunk is large and flat. Due to increased susceptibility to ignition noise, mounting the antenna in the hood area is discouraged. Follow antenna manufacturer's recommendations carefully during installation.

The **SBE-29CB** is supplied with a universal mounting bracket and microphone holder. The transceiver may be mounted in any position and on any rigid surface, such as underneath an automobile dashboard, truck roof or vertically on a boat bulkhead.

The transceiver should be mounted with accessibility and operation convenience in mind.

CAUTION: Avoid mounting the transceiver in the direct air stream of the vehicle's heater. Temperatures in this area can exceed 150° F and can result in serious damage to the unit.

It is recommended that the mounting bracket be installed on the transceiver and mounting clearances checked, with the unit held in the desired mounting position. It is especially important to leave sufficient space behind the unit for antenna and accessory cable connections.

When the most desirable mounting installation point has been decided upon, a pencil or other marking device should be used to outline the mounting bracket on the mounting surface. The transceiver should then be removed from the mounting bracket and the bracket held against the dash or other mounting surface, in the position marked, so that mounting holes may be marked and drilled.

CAUTION: Be sure to check behind the dash or other mounting surface to insure against damage of wiring and other devices before drilling any holes.

Install the microphone holder on the radio or other mounting surface as desired.

Install any accessories at this time, including external speaker, public address speaker, etc.

This unit is designed for either 12 volt positive or negative ground systems. In either system, the positive battery terminal always connects to the red supply wire, and the negative battery terminal always connects to the black supply wire. If the transceiver's power lead must be lengthened, use No. 14 or larger wire.

CAUTION: When using this radio in a positive ground system, it is important that none of the accessories are electrically connected to the vehicle's chassis (external speakers, P.A. speakers, etc.). Positive ground installations must utilize an additional 2 ampere fuse in the negative (black) supply lead to avoid possible damage to the transceiver. **NOTE:** The transceiver power lead may be connected to the accessory section of the ignition switch if desired. However, due to the possible presence of high-level noise from the ignition and accessories, this connection may not be desirable. In cases where excessive noise is present on the accessory line, a direct connection to the battery is recommended.

3.2 ANTENNA TUNING

The final step in installation is to trim the antenna for minimum S.W.R. The recommended method of antenna tuning is to use an in-line wattmeter or S.W.R. bridge to adjust the antenna for minimum reflected power on channel 11. A properly tuned antenna system will present a suitable load to the transceiver and will insure that maximum power is transferred from the radio to the antenna. If the antenna system in use presents a poor load, as indicated by a high S.W.R. reading, transmitter range will be substantially reduced and damage to the transmitter final amplifier transistor may occur. Poor S.W.R. can usually be corrected by altering the antenna's electrical length in accordance with the manufacturer's instruction. Extremely high S.W.R. readings may be indicative of a defective transmission line, antenna, or connections.

To determine whether the antenna should be lengthened or shortened, test the S.W.R. on channels 1 and 23. If the S.W.R. is the highest on channel 23, the antenna is too long and if highest on channel 1, the antenna is too short. When the antenna system has been tuned correctly, channel 11 should have the lowest S.W.R. and channels 1 and 23 will be slightly higher.

3.3 FINAL CHECK

Test drive the vehicle and make an operational check-out of the transceiver to insure proper operation of it and all the accessories installed. At this time, note any degradation of performance due to vehicle noise and take appropriate action to correct any noise suppression and deficiencies as outlined in the following section.

3.4 NOISE SUPPRESSION

The first step in assuring minimum ignition noise is to insure that the engine ignition system is in a good state of tune, and all factory original noise suppression devices are installed and operational. This includes an inspection of distributor points and condenser. Check to see that the spark plugs are clean and properly adjusted. The condition of the ignition wiring should be checked (radio resistor type ignition wire is standard on most late model vehicles and should be installed on vehicles not so equipped). The distributor cap should be checked for traces of carbon tracking or signs of arcing. Resistor type spark plugs are helpful in further reducing ignition noise and are standard as original equipment on many late model vehicles.

Alternator noise may be minimized by the installation of an alternator line filter, available from radio parts distributors.

Installation of bonding straps in the engine compartment will further reduce ignition noise. Short lengths of metal strap or heavy shield braid between the engine and frame, engine and fire wall, alternator and frame, exhaust pipe and frame, or hood to frame, will in many cases, greatly reduce ignition noise. Extremely high ignition noise levels or noise levels that become worse after a period of time are usually indicative of deterioration of the vehicle's electrical system. In some cases, interference may be caused by dash instruments including gasoline gauges, heater blowers and fans, etc. This interference may often be reduced by the installation of bypass capacitors from the terminals of the interfering instruments to ground. .01 microfarad capacitors of the ceramic disc variety rated at 500 working volts DC are recommended for this purpose.

For further information on the suppression of ignition noise in the automotive and marine environment, the Champion Spark Plug Company publication "Giving Two Way Radio Its Voice" is highly recommended. This publication is available from the automotive technical service department Champion Spark Plug Company, Post Office Box 910, Toledo, Ohio 43661. This publication is also available, at no charge, from the SBE Technical Services Department, upon request.

SECTION 4

CIRCUIT DESCRIPTION

4.1 INTRODUCTION

The SBE-29CB is an AM transceiver with a dual-conversion receiver using intermediate frequencies of 10 MHz and 455 KHz.

Refer to the block and schematic diagrams while following the circuit description.

TRANSMIT MODE is initiated by pressing the push-to-talk switch which energizes relay RL-1 which:

DISABLES:

- RX RF AMP (Q4),
- 1st RX MIXER (Q5),
- 2nd RX MIXER (Q6),
- 1st IF AMP (Q7),
- 2nd IF AMP (Q8),
- RX OSCILLATOR (Q1),
- 1st RX AUDIO (Q9),
- SPEAKER SP-1,

ENABLES:

- TX OSCILLATOR (Q3),
- TX MIXER (Q15),
- RX PROTECTION DIODE (D1).

When the push-to-talk switch is released, the transceiver is in RECEIVE MODE and the above states are reversed.

4.2 RECEIVER

In receive mode, an RF signal is fed from the antenna to the RF AMP (Q4). The amplified RF signal is then fed to Q5 — the 1st mixer — where it is mixed with an injection signal from the MASTER OSCILLATOR Q2 about 10 MHz below the receive channel frequency. The resultant 10 MHz 1st IF is selected by L1 and L2 and fed to Q6 — the 2nd mixer — where it is mixed with an injection signal from the RX OSCILLATOR Q1 455 KHz below the 10 MHz 1st IF. The ceramic filter FL-1 selects the 455 KHz signal and feeds it to the 1st IF AMP Q7 which then feeds it to the 2nd IF AMP Q8. The output of Q8 is fed through C24 to the AGC detection diodes D3 and D4, through C85 to the S METER detection diodes D15 and D16, and through C22 to the audio detection diodes D5 and D6. After passing through the AUTOMATIC NOISE LIMITER, the detected audio signal is applied across potentiometer VR1 — the volume control. The audio signal developed on the VR1 wiper is then fed to audio amplifier stage Q10 which then feeds Q11. The output of Q11 drives Q12 which is transformer coupled to push-pull speaker driver amplifier Q13 and Q14.

AUTOMATIC GAIN CONTROL CIRCUIT

The AGC (Automatic Gain Control) on the SBE-29CB reduces the gain of the receiver in response to a strong signal by lowering the bias on the RF and IF amplifiers. The AGC voltage is developed at the R2, R19 junction and filtered by C25. With a weak receiver input signal — less than $1\mu\text{V}$ — diodes D3

and D4 are forward biased by current through R2, R27, R28 and R19. About 1.5 volts of AGC appear at the C25, R19 junction. As the input signal increases, the signal at the top of C24 increases. When the signal at the top of C24 swings negative, current flows through D3 on to C24. As the signal swings positive, C24 discharges through D4. The increase in current through R2, R27, R28 decreases the AGC voltage. The AGC voltage is then fed through R1 and the secondary of T1 to the base of Q4, through R5 and the secondary of T2 to the base of Q5, through R19 and L2 to the base of Q6, and through R12 to the base of Q7.

THE AUDIO DETECTOR

The AUDIO DETECTOR on the SBE-29CB demodulates the received signal. The output of the 2nd IF AMP is fed from the top of the primary T5 through C22 to the detector diodes D5 and D6. When the signal at the top of T5 swings negative, D5 conducts current on to C22. As the signal swings positive, C22 discharges through D6 and charges C26. The voltage on C26 thus tends to follow the peak-to-peak voltage of the received signal and is thus the demodulated audio signal which is then fed through the AUTOMATIC NOISE LIMITING circuit, through C28 to the top of VR1 – the volume control, and from the wiper of VR1 through C39 to Q10 – the first stage of audio.

AUTOMATIC NOISE LIMITER CIRCUIT

The ANL circuit prevents impulse noise, such as ignition noise, from being amplified. The audio output voltage from the detector diodes D5 and D6 is reduced about 1/3 by voltage divider R20 and R21 and then fed to the cathode of D7 – the ANL diode. The audio output from the detector diodes is also fed through R22 to C27 where it is filtered and then fed through R23 to the anode of D7. Since the audio signal is positive, the signal at the anode of D7 is normally more positive than the cathode and the diode is forward biased providing a low impedance path for the audio to the first audio stage, Q10. When a noise pulse appears in the output of the detector, the time constant of R22 and C27 prevents the anode of D7 from responding as fast as the cathode. The cathode of D7 is thus driven more positive than the anode causing D7 to become backed biased. D7 then becomes a high impedance that blocks the noise.

SQUELCH CIRCUIT

The squelch circuit shuts the audio off when the received signal is less than the threshold level as determined by the SQUELCH CONTROL. If Q9 – the SQUELCH AMP – is off, R29, R30, and R31 form a voltage divider network that provides the proper forward bias to the base of Q10 – the first audio stage – permitting it to amplify the audio signal fed from the detector. Raising the wiper on VR2 – the SQUELCH CONTROL – tends to forward bias the base of Q9 which turns Q9 on. When Q9 is on, the forward bias is removed from the base of Q10 thus preventing amplification of the audio signal. As the received signal becomes stronger, however, the AGC voltage lowers the bias on Q9 which then permits Q10 to amplify audio. Thus raising the wiper on VR2 increases the threshold level a signal must overcome to “break squelch” – turn Q9 off and permit Q10 to amplify audio.

S METER CIRCUIT

In receive mode, meter M1 functions as an S-METER, and indicates relative strength of the received signal. When the signal swings positive at the top of the T5 secondary, current flows through D16 on to C85. As the signal swings negative, C85 discharges through D15 and charges C84. The voltage on C84 thus tends to follow the received signal strength. C84 discharges through VR5 – the S METER ADJ – to meter M1.

4.3 TRANSMITTER

In transmit mode, the output of the MASTER OSCILLATOR Q2 and the TX OSCILLATOR Q3 are mixed in the TX MIXER D12. The output of D12 is then fed through BAND PASS FILTER L4, and T8 (26.965 - 27.255 MHz) to the TX BUFFER Q15. The output of the BUFFER feeds the TX AMP Q16 which in turn feeds the TX DRIVER Q17. The TX DRIVER then feeds the TX FINAL Q18. The output of the TX FINAL is then fed through a low pass filter, L8, C78, L10, C80, L11 and C81, and a second harmonic trap CV1 and L12, to the antenna. Modulation is accomplished by driving the collector of the TX DRIVER and TX FINAL by modulated B+ derived from the lower secondary of T7 – the AUDIO OUTPUT transformer.

FREQUENCY MIXING SCHEME

Channel Selector switch S2 selects one of six crystals (X5 - X10) to set the MASTER OSCILLATOR Q2 frequency about 10MHz below the selected channel frequency. (See Table 5-3.) The output of Q2 is fed to the 1st MIXER Q5 to produce the 1st IF. S2 also selects one of four crystals (X1 - X4) for the RX OSCILLATOR Q1. The output of Q1 is fed to the 2nd MIXER Q6 to produce the 455 KHz 2nd IF. One of four crystals (X11 - X14) is also selected by S2 for the TX OSCILLATOR Q3. The outputs of the TX and MASTER OSCILLATORS are mixed in TX MIXER diode D12. The sum of the frequencies from these oscillators is selected to produce the transmitter frequency.

OVERMODULATION LIMITER

The OML regulates the gain of the audio amplifier so as to accommodate a wide range of voice levels without overmodulating the carrier. The audio signal is fed from the secondary of the audio output TRANSFORMER T2 to D18 where it is rectified; it is then filtered by C116, R40, and C43, and fed to the emitter of Q11 – the MIC AMP – through the OML adjustment VR4. As the sound level into the MIC increases, the voltage at the emitter of Q11 will rise and thus lower the amplification of the sound input.

OSCILLATORS

Crystal oscillators Q1, Q2 and Q3 are common collector, colpitts circuits. Outputs are taken from the emitters. The collectors of Q1, Q2 and Q3 are at AC ground.

RF OUTPUT METER

In transmit mode, meter M1 functions as a transmitter power output indicator. A small sample of the transmitter's RF output signal is fed by C82 to network R64, D14, and C11 where it is rectified and filtered and then fed through VR6 – the RFO ADJ – to meter M1.

FIG. 4-1 SBE-29CB TRANSCEIVER BLOCK DIAGRAM

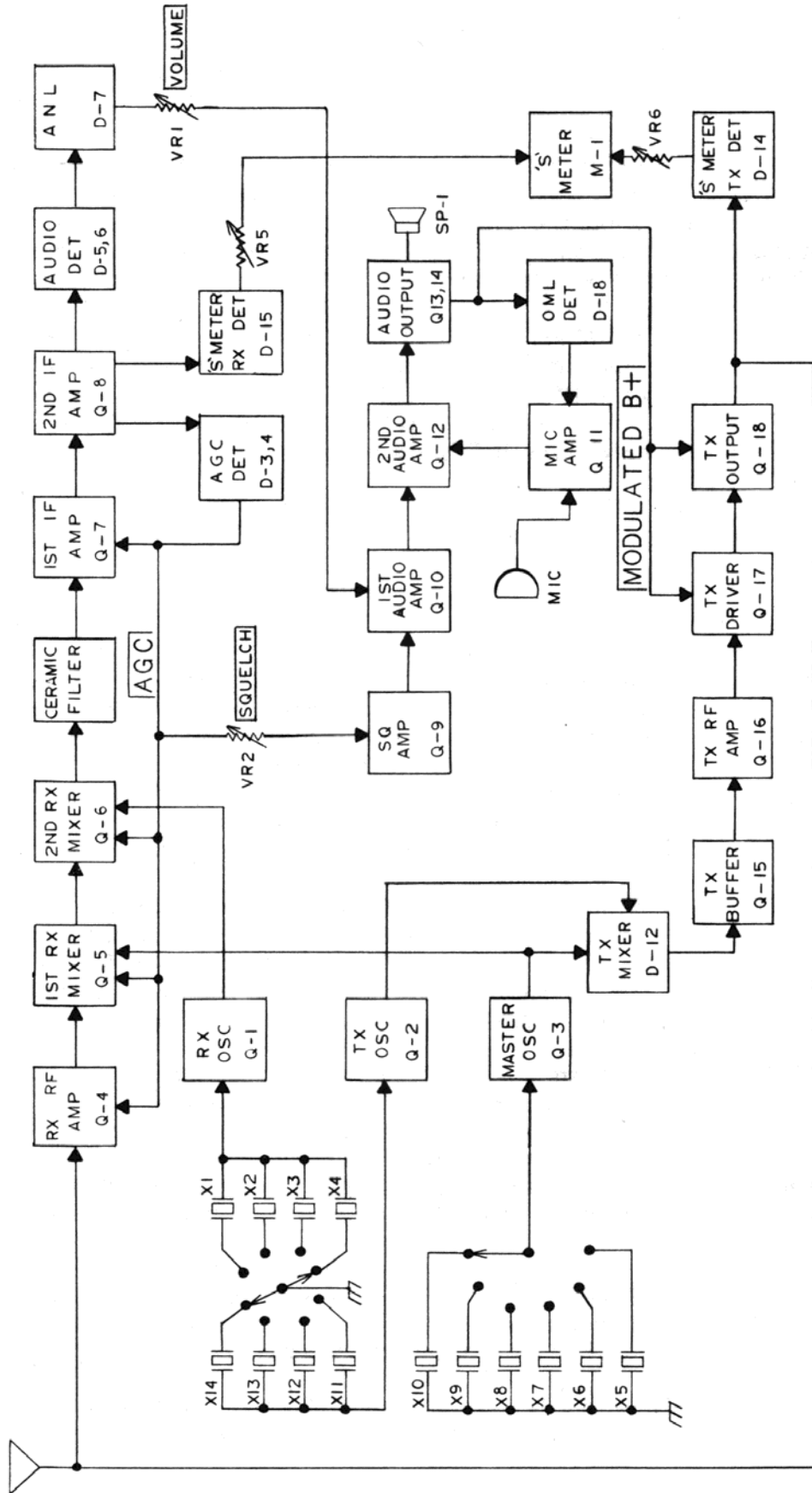

SECTION 5

SERVICING

5.1 INTRODUCTION

Read this section carefully before attempting any repair of the SBE-29CB. Refer to the circuit description, block and schematic diagrams. The transistor case diagrams are shown on the schematic diagram. Refer to these diagrams before checking transistors. Component layout and location prints are provided to aid troubleshooting and alignment. Use only recommended replacement parts. Refer to the parts list in the back of this book. **Never replace blown fuses with higher rated ones or fast acting with slow blow.** To check operation of the unit, refer to Table 5-1, PERFORMANCE VERIFICATION PROCEDURE. Figures 5-4, -5, TRANSMITTER TEST CONNECTION and RECEIVER TEST CONNECTION respectively, show the proper manner to connect the unit to test instruments for performance verification or alignment. Table 5-2 lists RECOMMENDED TEST INSTRUMENTS. Tables 5-10, -6 show the proper TRANSMITTER ALIGNMENT PROCEDURE and RECEIVER ALIGNMENT PROCEDURE respectively. Figure 5-8, ALIGNMENT LAYOUT is placed next to the alignment procedures to show alignment adjustments at a glance.

5.2 TEST SIGNALS

OSCILLOSCOPE WAVEFORMS are shown which were taken from various points in the SBE-29CB during normal operation into a dummy load. CHECK POINT numbers next to the waveform pictures correspond to numbers in boxes on both the schematic diagram and component layout drawing. Figure 5-11 shows RF amplification through a properly aligned transmitter. Figure 5-12 shows 50%, 100% and overmodulation respectively. Notice that the waveform at the ANODE of D12 – the TX MIXER – contains several frequency components. Also notice that the waveform at the collector of Q18 – the TX FINAL – is unsymmetrical (Figure 5-11e). This is proper since the TX FINAL operates class C for greater efficiency. Figure 5-11f shows how the output should look at the dummy load.

VOLTAGE MEASUREMENTS are shown on the schematic diagram for normal operation. All voltages were measured with an AC VTVM having $10M\Omega$ input impedance. Voltage measurements on high impedance RF points should be taken through a choke. While any choke about $100\mu H$ is suitable, SBE part number 8000-00011-0018 ($150\mu H$) may be ordered from the factory. Mini-test clips are very useful for making voltage measurements in hard to reach places.

RECEIVER INJECTION VOLTAGES are given in Table 5-9 together with CHECK POINT numbers which correspond to numbers in boxes on both the schematic diagram and component layout drawing. This table specifies the voltage level, carrier frequency and particular points in the receiver string at which a 30% - 1 KHz modulated signal injected through a .01 MFD capacitor should produce 2 VAC of audio across the speaker or 8Ω load plugged into the speaker jack, EXT SP. While the value of this capacitor is not critical, capacitive coupling of the signal generator to the circuit is necessary to prevent grounding out the transistor biases.

Before setting up to measure RECEIVER INJECTION VOLTAGES, small hand-held "all-purpose signal generators" can be used to provide a quick check of the receiver string. Basically, these devices generate pulses rich in harmonics from AF to RF to test whether a stage is working.

AGC VOLTAGES versus RF INPUT LEVEL are shown in Table 5-7. This table should be consulted before any adjustments are made on the squelch circuit since squelch is a function of AGC.

5.3 TROUBLESHOOTING

Troubleshooting the SBE-29CB transceiver is not essentially different than troubleshooting any other electronic device. Be a detective; suspect everything and everyone. Carefully inspect the unit for evidence of overheated components, cold solder joints, or tampering. Understand thoroughly the circuit description and block diagram. Try to start big and isolate the problem. Devise tests that will divide the transceiver in two and isolate the trouble to a particular half. Continue to divide into two parts until the trouble is located. For example, it is determined that a problem exists in a particular transceiver. The unit is divided into:

TRANSMITTER – RECEIVER.

Suppose that the receiver functions properly but there is no carrier when the transmitter is keyed. Since the receiver audio works, it can be assumed that all of the audio amplifier is good except the MIC AMP Q10 – the condition of which is yet unknown. The MASTER OSCILLATOR can be assumed working since it is used by both the transmitter and receiver. After checking the TX/RX relay RL-1 and transmitter B+, the transmitter is then divided into:

BEFORE TX AMP – TX AMP and AFTER.

Figure 5-11, TRANSMIT ALIGNMENT WAVEFORMS, shows typical waveforms taken at various points in an SBE-29CB transmitter during normal operation. Place an oscilloscope probe on the collector of Q15. If a signal is present and doesn't differ significantly from the waveform picture then the problem exists after Q15. Keep dividing until the trouble is found.

This technique is sometimes called, "partitioning," "boxing-in-the-trouble," "divide and conquer," or "binary search"; it is mandatory for complex electronic systems, but can save time and energy on almost any electronic device.

A blown fuse should only be replaced by one of the proper rating and type. If the fuse blows again, replace it, but place an Ω meter at the power terminals in place of the supply. Make certain that the + side of the Ω meter is connected to the red power wire of the SBE-29CB. Some VOM's place the - side of the Ω meter out the red test jack. Observe that D17 protects the unit from a reversed supply. The push-to-talk switch can be used to start isolating the short.

A fuse may blow only when the unit is connected in a vehicle because the vehicle has a positive ground and there is a short from the PCB ground to the chassis, or a grounded speaker was plugged into EXT SP J2.

The second harmonic trap (L12 and CV1) is adjusted at the Factory; field adjustment should not be attempted without proper equipment. Failure of particular channels to work or be on frequency probably indicates a defective crystal. Refer to Table 5-3 SYNTHESIZER MIXING SCHEME. Notice that the same Transmit and Receive crystals are used every fourth channel while each Master crystal is used on four adjacent channels. Check channel selector switch, S2, by swapping crystals.

FIG. 5-1 PERFORMANCE VERIFICATION PROCEDURE

TRANSMITTER

INITIAL SET-UP

Connect the SBE-29CB to a 13.8 VDC supply. Connect a wattmeter, dummy load and oscilloscope to the antenna jack.

STEP 1

Key the transmitter and observe that the wattmeter indicates an output of at least 3 watts and that the RFO meter indicates about the same.

STEP 2

Whistle into microphone with transmitter keyed. Check for 90-100% modulation.

STEP 3

Connect counter to dummy load and check transmit frequencies on channels 1, 2, 3, 4, 8, 12, 16, and 20. (See Table 5-3.)

RECEIVER

INITIAL SET-UP

Connect SBE-29CB to 13.8 VDC supply. Connect RF signal generator to the antenna jack and set to 27.085 MHz 30% - 1 KHz modulation. Set the unit to channel 11. Turn the volume control full clockwise and the squelch control full counterclockwise. Connect 8Ω load to external speaker jack, EXT SP, and connect AC VTVM to 8Ω load. (See Figure 5-5.)

STEP 1

Adjust signal generator for $0.7\mu V$ output. Verify that at least 2 VAC appear across the 8Ω load.

STEP 2

Increase signal generator output to $200\mu V$. Rotate squelch knob full clockwise. Receiver should squelch.

STEP 3

Adjust signal generator for $100\mu V$. S-METER should read about 9.

FIG. 5-2 RECOMMENDED TEST INSTRUMENTS

| <u>TEST INSTRUMENT</u> | <u>REQUIRED SPECIFICATIONS</u> | <u>USE</u> | <u>RECOMMENDED INSTRUMENT TYPE</u> |
|------------------------|--|--|---|
| R.F. Signal Generator | Output frequency: 26.965 to 27.255 MHz. Output level calibrated from .1 microvolts to 500,000 microvolts. Internal modulation capability of 30% minimum at 1 KHz. (Calibrated) | Receiver service and alignment. | Hewlett-Packard Model 606A or B. Wavetek Model 3000. |
| Oscilloscope | Vertical bandwidth of 25 MHz or greater at 3db point. Triggered sweep capability. | Transmitter and receiver test and alignment. | Tektronics Model T932. Tektronics Model 465. Hewlett-Packard Model 180. Phillips Model PM3260E. |
| Frequency Counter | Frequency range DC to 30 MHz. Sensitivity: 10mv R.M.S. at 30 MHz. Overall timebase accuracy $\pm .002\%$, 6 digit resolution. | Transmitter frequency check and synthesizer troubleshooting. | Heath-Schlumberger Model SM128A |
| Wattmeter | 5 watts full scale into 50 ohm load $\pm 5\%$ accuracy. | Measure power output and S.W.R. | Bird Model 43 with type 5A element. (May be terminated with antenna load |
| AC VTVM | -40 to +20db range. | Measure audio output. | Heath Model IM-21. |
| Audio Oscillator | 400 Hz to 4000 Hz output: Adjustable level, 0-1 volt output impedance 600 ohm. | Audio and modulator tests. | Hewlett-Packard Model 204C. Heath Model SG18A. |
| DC Power Supply | 13.8 volt DC $\pm 10\%$ at 2 amperes. | Primary supply voltage for servicing. | Heath Model SP2720 (SBE Model SBE-1AC may be used if available.) |