

SECRET CB[®]



CONFIDENTIAL
**FACTUAL
REPORT**
SCHEMATICS ETC.

ACKNOWLEDGEMENTS

SECRET CB WISHES TO GRATEFULLY ACKNOWLEDGE THE FOLLOWING PEOPLE FOR THEIR HELP AND CONTRIBUTIONS TOWARD GETTING VOLUME 20 IN PRINT. THEIR ENCOURAGEMENT AND CONTRIBUTION OF MATERIAL HAS BEEN INVALUABLE.



CARL CLARK
DON GARRISON
LES JERNIGAN
T. J. JOSEY
GREG LOWRY
MARK MILLER
LESTER SJERVEN
JAMES VAUGHN
BILL WENTZ

WANTED

NEW MODIFICATIONS
NEW CONVERSIONS
TECHNICAL TIPS
PROJECT PLANS
ETC. ETC. ETC.



DORIS SAYS "THANKS" AND A FREE BOOK TO THE ABOVE PEOPLE.

INTRODUCTION

Hi!

Here is "SECRET CB" Volume 20 packed full of good information as always. We know you will like it.

Have you been waiting for the answer to the "SUPER DIODE CROSSWORD PUZZLE"? We are happy to announce that JUDI STEPHENS (Lady Outlaw) is the one and only winner of the contest. Turn to page 16 for the answer.

We are always trying to make improvements and we have made one to the INDEX - a new format that we hope you will like.

We have some "NEW PRODUCT RELEASES". A complete SERVICE MANUAL with schematics for the STALKER 9 Export radios (regular and UK model). Two new "CUSTOM CONVERSIONS" - CC#25 for MAJOR M-120 and CC#26 for MARKO CB-144. Step-by-step instructions for adding 111 channels on the low side. Final Coverage 25.685-28.305 MHz. NOTE: One "SUPER DIODE" is required per unit.

The new products are available now at Selman Enterprises. If you do not have our "SECRET CB" Product Catalog ask for one. If you would like to be on our Automatic Mailing List to receive each new "SECRET CB" volume as it is released, please call or write and we will send you an AML form.

UNTIL "SECRET CB" VOLUME 21!

Always sincerely yours,



Doris Selman



TABLE OF CONTENTS CONTINUED:

	PAGE
SAMS CROSS REFERENCE; HELP.....	54
GE3-5826A SSB MOBILE SLIDE MOD.....	54
HINTS/KINKS/GOOFS.....	55
GE3-5825B SSB FREQ/SLIDE MOD.....	55
MIDLAND 77-830 CONVERSION TO 26.435-27.405 MHz.....	56
FIELDMASTER MICRO-MINI 40 SCHEMATIC.....	57
SOMMERKAMP TS-340DX AND GLOBEPHONE GS-480DX SCHEMATIC....	58
UNIDEN PC-77 SCHEMATIC.....	59
UNIDEN PC-55 SCHEMATIC.....	60
K-40 SSB CLARIFIER MODS.....	61
SUPERSTAR 120 (AM/FM) SCHEMATIC.....	62
EXPORT LIST - TO BE DROPPED FROM REFERENCE.....	63-64
PALOMAR 5000 INFO.....	64
SATELLITE PROGRAM INFORMATION.....	65-68
"SECRET CB" INDEX FOR VOLUMES 1 THRU 19.....	69-76
OOPS! WE GOOFED! AND CORRECTION INDEX.....	72
CORRECTIONS IN THIS VOLUME.....	76

TRAM PARTS SOURCE

This company has informed us that they basically have all of the parts available on the TRAM radios and also are doing repairs to the TRAM radios.

SATELLINK COMMUNICATIONS CORP.

Lower Bay Road Drawer C

WINNISQUAM, NEW HAMPSHIRE 03289-0303

(603) 524-0622 524-0623

CALL OR WRITE TO SELMAN ENTERPRISES, INC. AND ASK FOR OUR
"SECRET CB" PRODUCT CATALOG. (512) 853-2935

P.O. Box 8189, Corpus Christi, TX 78412

Letter from the Editor,

This makes the 5th volume of Secret C.B. I've written/correlated since June of '83. Volume 16 started the 're-vitalization' of the entire format, which was needed. I hope the present layout is more to your liking.

When I took on the task of writing Secret C.B., had one strict rule set down in advance: NO modifications printed on AM units above 27.405MHz! So if you are wondering what has happened to them, File-13. Also would refrain as much as possible from repeating prior printed information. This is the reason for the 'refer to...' since that time. I do suggest you obtain any missing volumes; as they are going fast; especially #'s 1 & 2!

I do realize that all the readers don't have an electronics background, and for that reason haven't been more technical. But this has been to an advantage for the 'Screwdriver Jockey' with the drawings now.

Couldn't understand the failure of the Newsletter type of monthly publication...as get plenty of mail/calls all the time: 'where do I get this-do you have, etc.'? Any late breaking info. isn't passed around fast enough to those who require in their occupation.

For this reason 'The C Team' was formed back in May of this year, with the main objective of correlating/passing on information, and since Volume 18 has been the biggest contributor to 'SCB'. I would like to see more contributors of material, so we could expand to maybe 5 or 6 issues a year, and keep current with ideas/modifications.

When sending information on units: PLEASE; send Owner's Manual and schematic if possible. Don't fold the schematics, as copying machines are so sensitive will pick up the crease. Some large schematics have been sent in mailing tubes, which are perfect. Before sending manuals and schematics, drop a postcard in the mail, to avoid duplication of material. Some contributors have gotten upset about not getting a free issue, when they sent in material. Sorry, but strictly 1st person basis. A lot of 'free-bies' have been given out on information for the 'Hints-' column.

Always include note with name/address, and state you want any of your material back. Original Owner's Manuals and schematics will be returned 1st Class, same day in most cases. I don't have access to 90% of units written up in SCB; so when asking for specific information on radio; usually only have a schematic to go by.

My opinion on the 'Exports' is varied: the 02A chip AM/FM units are your best all-around buy if you already possess an SSB unit. If you don't have an SSB unit; by all means latch onto a Jackson-DX; which is scarce now. The 02A units; can usually be modified for another 100+ channels in either direction; at minimum expense-if you do the work. The Jackson-DX is the best thing going at this time, and highly modifiable. Best set-up I have seen to date was: Major M-120 with the Alpha Mod, and President Adams with 'X2' Mod. Person had coverage from: 25.685 to 28.305MHz in AM/FM, and 24.135-29.805MHz in AM/SSB. (This Adams was a one-of-a-kind unit, strictly Custom Built!).

I don't live in Corpus Christi; so all correspondence goes to Doris for remailing when the pile gets big enough to make it worthwhile. For those who somehow have gotten my phone number; I eat at 5:30CST; and don't like cold food! If you have to, call after 8:30PM...

Editor,

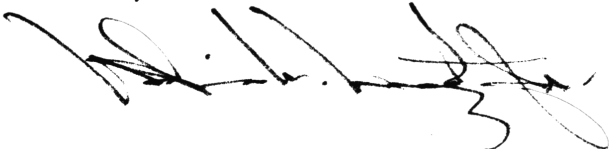

R/S-1175 (Noise Cancelling Amp. Mic.) "EXPORT" Hook-ups.

Note: (*) - If hum or squeal appears when wiring, may have to be removed.

Chart #1

<u>Unit</u>	<u>Old Wiring</u>	<u>New Wiring</u>
Superstar 120 (AM/FM & AM) Pacific 800 SSB Stalker 9FM & 9FDX Grant Jackson Cobra 148GTL-DX (Early and Late)	1. Shield, Ground 2. Audio 3. Normally Open 4. Normally Closed	1. Shield, Blue (*) 2. White 3. Red 4. Black

Chart #2

<u>Unit</u>	<u>Old Wiring</u>	<u>New Wiring</u>
Palomar, Colt, and Lafayette 2400 Ham Inter. Multimode 3; M788 Superstar 2000 (Both versions) NATO 2000 Major M-120 Tristar 727 Superstar 95 Midland 2001 (Export) Colt 510 Commtron XII	1. Audio 2. Shield, Ground 3. Normally Closed 4. Normally Open	1. White 2. Shield, Blue (*) 3. Black 4. Red

Chart #3

<u>Unit</u>	<u>Old Wiring</u>	<u>New Wiring</u>
Marko CB-444	1. Audio 2. Normally Open 3. Shield, Ground 4. No Connection 5. Normally Closed	1. White 2. Red 3. Shield, Blue (*) 4. No Connection 5. Black

R/S-1175 "Export" Hook-ups (Cont.)

Chart #4

Note: External Volume Control is Disabled. (*)

<u>Unit</u>	<u>Old Wiring</u>	<u>New Wiring</u>
Sommerkamp TS-340DX(*) Globephone GS-480DX(*)	1. Shorted to Pin 3	1. Short to Pin 3
	2. Ext Vol. Control	2. No Connection
	3. Shorted to Pin 1	3. Shorted to Pin 1
	4. Audio	4. White
	5. Ext Vol. Control	5. No Connection
	6. No Connection	6. No Connection
	7. Normally Open	7. Red
	Case-Shield, Ground	Case-Shield, Blue (*)

Chart #5

<u>Unit</u>	<u>Old Wiring</u>	<u>New Wiring</u>
Superstar 360 (AM/SSB/CW)	1. Audio	1. White
	2. Shield, Ground	2. Shield, Blue (*)
	3. Normally Closed	3. Black
	4. Ground	4. No Connection
	5. Normally Open	5. Red

Units not listed in charts haven't schematic to work with. If you have unit that needs wiring for, be patient - maybe someone will send in the schematic.

This chart will not be repeated in future volumes, but reference back to it will be made. Additional chart/s will be added if needed.

The following conversion is reprinted by permission of "Custom Conversions", and its author. NOTE: The first 2 pages and Fo Chart are condensed...

(1) CUSTOM CONVERSION #10
(Code Name: Wild Goose)

Chassis: Realistic TRC-431 (21-1544)

Parts Cost to modify including SAMS \$30 max...

Time to modify - INITIAL unit 4 hours, with all parts on hand!

Gain in Unit: Frequency Range - - 26.325-27.405MHz

R.F. Gain Control

High Frequency Audio Filter

Modified Noise Circuitry

"Illegal Frequency Alert"

Universal D.C. Jack

Internal Mike Gain Control (optional)

Loss in Unit: P.A. Capability

Headphone Jack use

Initial conversion performed on S/N 7320LXXX, Run 5A7.....

(2) Realistic TRC-431 (21-1544).....Code-Wild Goose, S/N: _____

This unit is extensively modified for operation between the frequency range of 26.325-27.405MHz. Total 'channel' capability is 92 AM 'channels'.

Frequency is determined by the main channel selector and the 'range selector button/jack'. In this case the P.A. push button (Code-Red), and Headphone jack (Code-Blue).

At any time the unit is capable of transmitting on an 'Illegal Fo' the lamp in RF/S meter will be out. Delta Tune is eliminated, and converted to a R.F. Gain control.

A "Universal D.C. Jack" has been installed on back for use with standard 3-pin plug, and 2Amp AGC ONLY fuse inline.

CCW adjustment to the installed variable resistor on etch side of PCB will 'pad' the unit, preventing overmodulation when using amplified microphone.

A Bandit antenna will tune over the entire range if used in mobile configuration. Do not exceed 1.5 SWR if possible.

(3) For complete Wild Goose Fo Chart, see Volume 16, pg. 16.

Red Code - Selector Pos. 12-22, 24; 26.785-26.915MHz.

Blue Code - Selector Pos. 1-40, ... 26.325-26.765MHz.

The next page starts the actual conversion.....

NOTE: DIAGRAM BELOW IS FOR USE WITH SAMS, AS IS NOT IN THEIR PUBLICATION.
PLL CAGE COMPONENT SIDE....

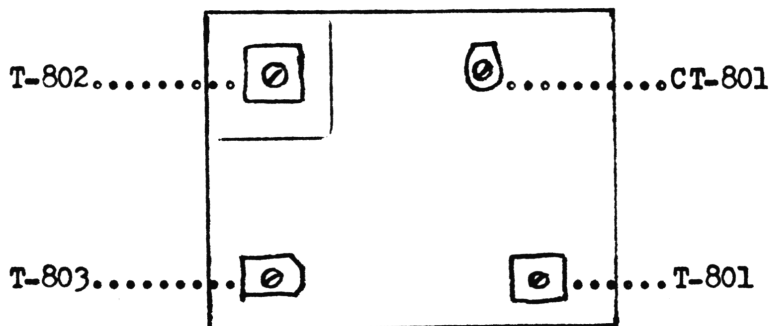

Read thru this and write down all parts you will need to perform the conversion before attempting! DO NOT ATTEMPT TO CONVERT WITHOUT THE FOLLOWING: SAMS #237, Dummy Load, Frequency Counter, and Power/Modulation Meter are the minimum needed.

1. Remove Top, Bottom covers.
2. Check all Power Transistors; make sure they have thin mica insulators; if not-CHANGE.. (Note: some production runs had them.)
3. Use built-in power supply for all of conversion process.
4. Cut all cable ties inside chassis,CAREFULLY.
5. Remove P.A. Switch Assembly from chassis, carefully (2 screws from behind front panel) pull up out of the way. Leave button in out position. Tie out of the way, so not shorting to anything.
6. Remove knob on Delta Tune Switch, carefully remove switch and pull up out of chassis.
7. Cut Blue wire off switch, trace to PCB-remove.
8. Cut Violet wire off switch, trace to PCB-remove (Note location).
9. Cut Red wire off switch; re-route to where Violet wire was removed; cut to length and re-wrap at pin.
10. Remove Front Nut on Headphone Jack carefully as not to scratch case. 'SAVE nut, as will need later.
11. If ground strap for Jack assy will not come loose in the chassis, cut it as not necessary. (Bend it back out of the way)
12. Gently pull jack up out of chassis, cut Black wire off at the board and leave hanging where it won't touch anything!

13. Cut remaining wires off board.
14. Strip $\frac{1}{2}$ " insulation off of Blue and Violet wires, twist together. Turn unit on, check for audio. Turn off...
15. Untwist wires, trace Blue wire to PCB, cut $\frac{1}{4}$ " from where it is wire-wrapped, leave hanging out of bundle.
16. Trace Violet wire to P.A. Push Button Board; on top of switch is a Blue wire-cut off and trace back to PCB (Audio Xfmr); cut Blue wire to same length as the other.
17. Strip $\frac{1}{4}$ " insulation off both Blue wires, splice/solder/sleeve. Turn unit on, check for audio. Turn off...
18. Cut the Violet wire left hanging on the P.A. board. Leave that Black wire hanging, (Step 12)!!
19. Use Diagram below for removing remainder of wires from P.A. Switch. Do exactly as written, do not deter...

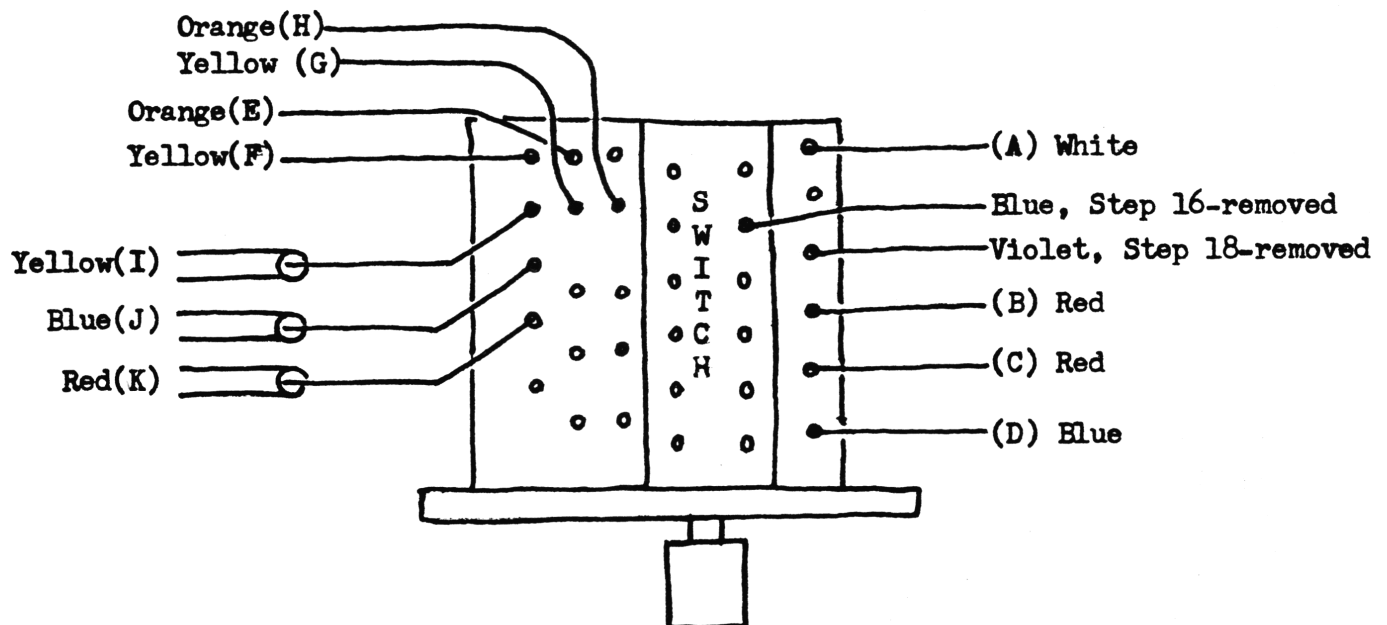

A. Cut White wire, trace to PCB-remove.

B & C. Cut both Red wires off.

1. Trace one to PCB, pull out of bundle (Do NOT remove), let hang.
2. Trace other wire back to microphone conn., re-route to where other red wire was wire-wrapped in Step 9. (Standoff next to Q505) SOLDER to standoff.

D. Cut Blue wire off, trace to PCB-remove.(Note location)
Re-route Red wire left out of bundle, route to the right and wire wrap where Blue taken off.

E. Cut Orange wire off, trace to standoff coming out of PLL cage, pull out of bundle, leave hanging.

F. Cut Yellow wire off, trace to PCB-remove.(Note location)
Re-route Orange wire to that point and wirewrap.

NOTE: Some production runs have stand-off on right rear side, if Orange wire will not reach, replace with same color wire

- G & H. Cut both Yellow and Orange wires off, trace to Squelch pot.
Cut both wires off, delete.
- I. Cut Yellow Cable off, ground also-trace to ON/OFF-Volume Pot.
Cut off-delete.
- J. Cut Blue Cable off, ground also-trace to PCB, remove completely.
Note location..
- K. UNSOLDER Red Cable carefully, re-route to where Blue cable was.
Solder Ground first to rear standoff SP-, then Solder hot side
to standoff PA3. Note-make sure ground is not shorting anything.
20. Turn unit on, check audio on TX and RX.
21. Remove both PLL covers carefully.
22. Do a complete line-up per SAMS #237..
CAUTION: Slugs are glued in some sections of these units.
Trying to loosen up will only cause you to bust them-good luck!
NOTE: Original Final 2SC1909 is rated at 1.5W/3A, so don't push
it unless you want to replace it. If you want to replace use a
2SC1306. Also you might want to replace the Power Supply Filter
Capacitor with a 5,000mfd/50VDC, it is not necessary.
23. Double check the modulation using an unamplified microphone,
(This unit had a maximum adjustment of 70%, had to remove C-511
a 3.3mfd/50VDC electrolytic) If you do remove capacitor will
now overmodulate with an amplified microphone if used.
24. If an amplified microphone is going to be used-remove R-709 (1.5K).
Replace with a 50K Variable resistor (2 legged type). Solder on
etch side of PCB where you removed R-709. Bend over so it clears the
bottom cover. This is now your mike gain control...
25. Carefully remove VR-1 so as not to mess up the resistance setting.
Measure resistance at points shown below, legs down on VR-1.
Note: In this unit measured 62K, have found most to read within 13K.



26. Obtain a 50K pot for new RF Gain Control in Delta Tune position.
Make sure it is a miniature pot, and Delta Tune Knob fits, also the
shaft length might have to be cut.
27. Use a Violet and Blue wires that have been discarded (there are 2
approx. 11" long-perfect fit).
A. Solder Violet wire to center leg of pot, sleeve.
B. Solder Blue wire to left leg, sleeve (View from shaft end)
C. Double check for ohms decrease in C.W. movement.
D. Install in chassis, tighten down nut, turn pot fully C.C.W.,
put on knob.
28. Solder a 27K $\frac{1}{4}$ W 5% in following diagram, solder Violet wire to resistor.
Solder Blue wire in place also. (Sleeve resistor/wire solder joint)
All to be done on component side. Will have to back off on RF Mtr a
adjustment to keep from pegging meter in max RF Gain when checking out.

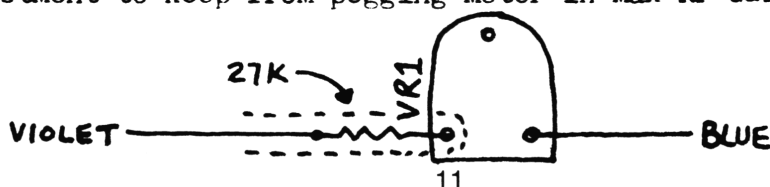

29. Obtain a 50Mfd/50V NON-POLARIZED electrolytic, sleeve both ends. Solder one end to where Blue wire is on the speaker, solder other end to Black wire (left hanging since Step 18). Turn unit on, check for audio quality. If too muffled decrease capacitance of capacitor, NOT Voltage!

*** AT THIS TIME GO BACK AND REALIGN ALL RECEIVE CIRCUITS AT 26.965MHz (CH. 1). *** DO NOT MAKE ANY ADJUSTMENTS IN THE PLL CIRCUITRY!!!

30. Completely clean the P.A. Push Button Switch Assy./Holes and pins, double check for no shorts!

31. Obtain from Radio Shack the following:

Enclosed $\frac{1}{4}$ " Stereo Phone Jack-P/N 274-277 (1)

2-Conductor $\frac{1}{4}$ " Phone Plug-P/N 274-1544 (1)

4-Conductor Ribbon Wire-P/N 278-757

Note: Ribbon Wire, check to see the colors are Red/Black/Green/White. If not the reference to color wires will not correspond in following steps.

32. Retrieve nut from Step 10, check for fit to new Stereo jack.

33. Trace White wire from meter lamp to PCB. Unsolder carefully, (Note-two White wires in hole), clean out hole. Pull meter lamp wire up out of the way. There is a long piece of White wire deleted earlier, solder both it and other White wire back into the hole in PCB. You should have two pieces of wire hanging out now. (one to meter lamp, other long piece from PCB.)

34. Cut off 12" of ribbon cable, carefully peel the Red off.

35. Wire up the Stereo jack using diagram below, solder lamp lead last.

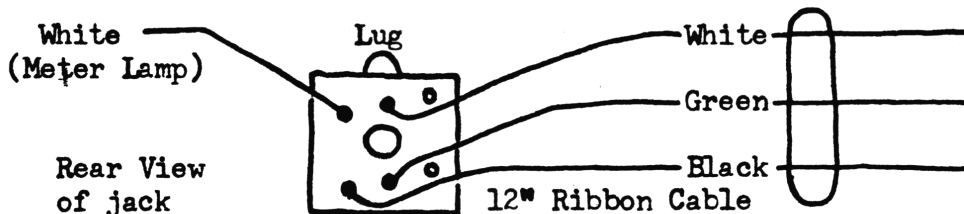

Check continuity on wire ends-Whites normally closed-open when plug in. Green and Black normally open-closed when plug in.

36. Install jack in Headphone hole, Carefully tighten down.

37. Wire the P.A. Switch Assy with 10" of ribbon cable per diagram below:

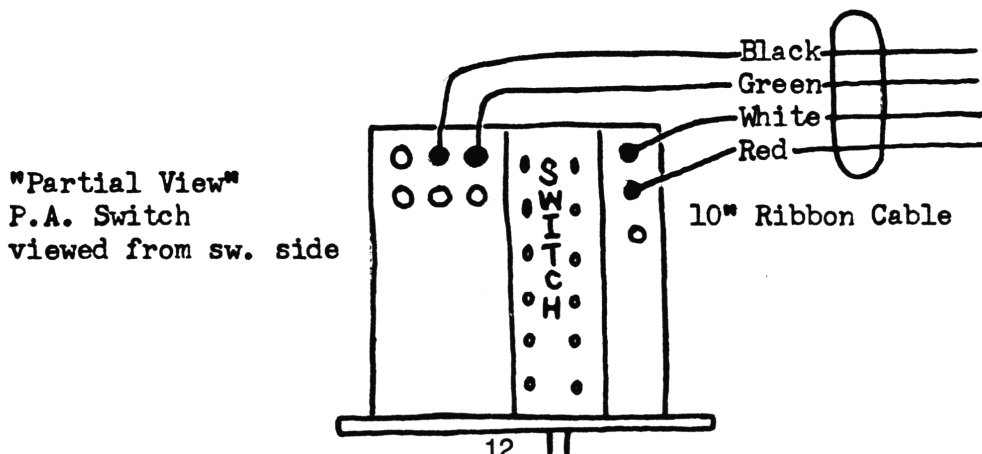

38. Wire cable coming from the Headphone jack to the P.A. Switch Assy. per diagram below...Note "A", next to white wire...

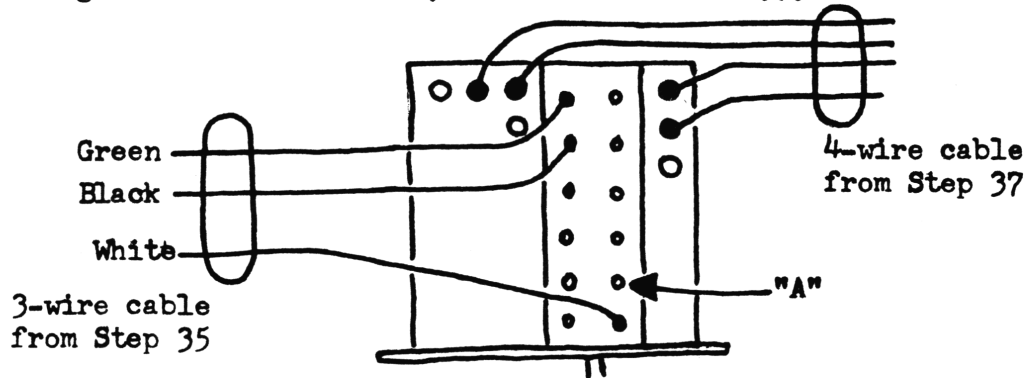

39. Install switch back into chassis exactly as shown, don't overtighten as will strip plastic!...Note "A", next to White Wire...

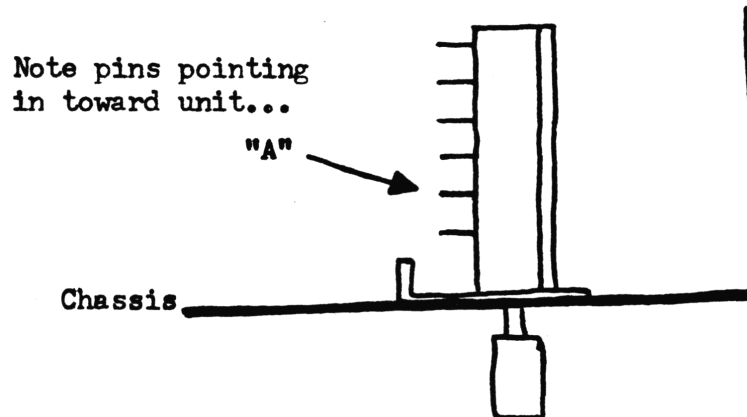

40. Route the long White wire soldered to board in Step 33 to P.A. Sw. - cut to length, sleeve/solder to "A" (See diagrams above)
41. Turn unit on. Push PA button in-light on meter should go out. Insert plug into Headphone jack, light should still be out. Push PA Button out-light still out; pull plug-light on..
42. Do following exactly as written - Don't deter or might possibly damage PLL Chip in further steps...
- A. Pull plug on unit..
 - B. Turn unit ON (This will bleed off all voltage)
43. Caution: Use battery operated Soldering Iron or Isolated Tip Iron when working on the PLL Chip.
44. Carefully unsolder the small metal top inside the etch side of the PLL cage - Clean up all excess solder and check for shorts.
45. Route the 4 wire ribbon cable down to the underside of the chassis to the PLL cage, leave some slack for tying up cable later.

Use diagram on next page and follow directions to the letter!

45. Diagram:

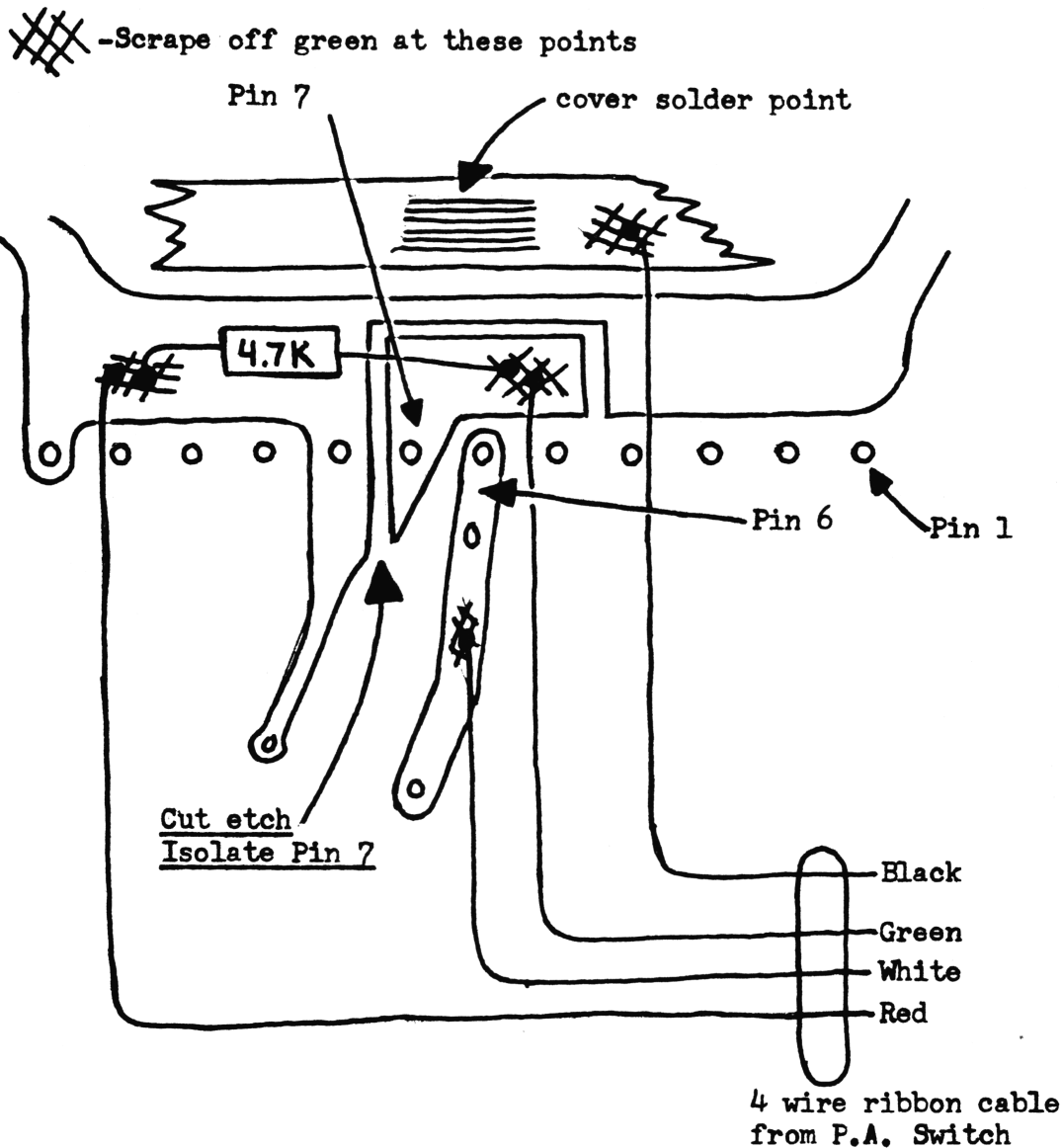

- A. Scrape off insulation at places marked with XXX.
- B. Completely isolate Pin 7 from Pin 8, make cut as shown.
- C. Bridge cut with 4.7K $\frac{1}{2}$ W as shown, bend leads so resistor is flat on board.
- D. Cut to length and solder wires of cable exactly where shown. Leave some slack for routing above and thru slot in side of case.
- E. Double check for shorts, and etch slivers.
- F. Check for Insulation on small cover, if none use elec. tape on bottom. Then solder back in place carefully.
- G. Lay all wires down and put bottom cover back on the etch side PLL case.

46. Turn unit on and using Frequency Range Selectors and Chart, check for Freq. spread.

- A. Using L-901, 902, 903, 904 ONLY, see how far it will go; with at least 2W output. (Note: This unit had L-905 and L-907 heavily glued, every unit I have seen has been the same) DO NOT ADJUST L-910.....
- B. If you can't get full range, adjust T-802 and T-803; SLIGHTLY; and try again. Using above again.
- C. If you still can't get all the frequencies up. Remove C-906, (Sams says 13pf, found 15pf)
- D. NOTE: If you haven't done so yet-adjust CT-801 for exact center frequency.
- E. Using the 6 coils in A & B steps should be able to get it up with out too much trouble, be patient. (Note: took me 20 min.)
- F. Try to get a Freq/Pwr spread of at least following:
NOTE: THIS UNIT ONLY HAD 3.5W TO START WITH.....
26.325--3.1W, 27.405---2W+; If you get this should be O.K. as the spread was 26.325--3.1W, 26.805--3.4W, 27.405--2W+.
- G. Now go to 27.405 and peak L-910, this will pull up higher end of the band about .6W
- H. Put cover back on PLL case and recheck.
- I. Note: in case you tried busting loose L-905 and L-907. They are are about \$2.00, special order from Radio Shack. And only made a difference of .2W increase in output power. The Final was not changed in this unit-IF YOU CHANGE-do it before you start the initial lineup.

47. Tie up all cables CAREFULLY..

48. If you want to use a 3 pin D.C. connector (Radio Shack too flimsy, and won't stay in place). Turn unit upside down and drill/cut so metal won't get into the circuitry. See Diagram below

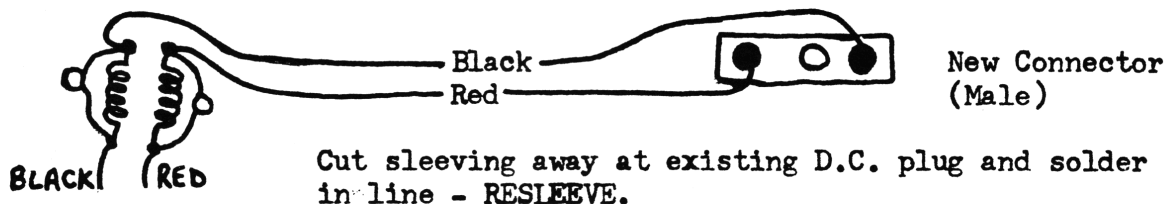

49. If you want to get more noise out of the unit - obtain a .003mfd/50V disc. capac. and solder carefully across pins 4 and 6 of IR-501. Some units might require more or less. (This unit - .0047mfd.) bend capacitor over so cover will not touch it.

50. Put covers on, ENJOY.....

!!!!CONGRATULATIONS TO JUDI STEPHENS (LADY OUTLAW)!!!!

THE ONE AND ONLY WINNER OF THE SUPER DIODE PUZZLE CONTEST.

ANSWER

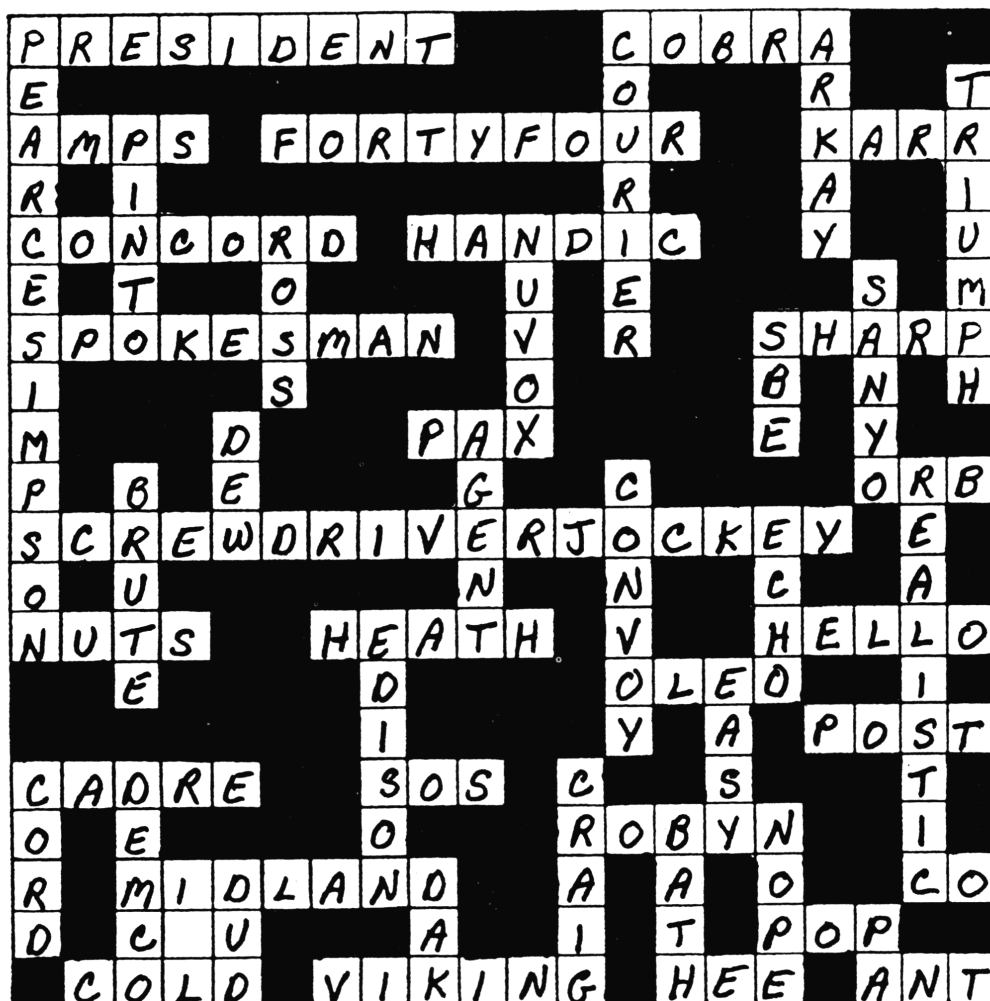

"Rating The Exports"
(Editor)

Am always asked, "Which is the best 'Export' to buy"?

Hard to rate them all as haven't seen or checked them all out.

Listed below are those 30+ units have seen/'played' with, and reports from the 'C Team'...

Units rated according to design, PLL Chip, Line-up/Schematic availability, Fo range, modifiability, and if has SWR Meter.

POOR

Pacific 800 SSB (Special Note; this unit would have been rated as Excellent! But the component I.D. #'s aren't printed on the PCB...

FAIR

Palomar 2400	Colt 510
Lafayette 1800	Superstar 2000 (Both versions)
Commtron XII	Tristar 747
Stalker 9FM	Stalker 9FDX
Midland 2001 (Export)	Superstar 95
Nato 2000	Thunder 2000
Stalker XX (Export) FM	Lafayette 2400
Palomar 5000	Tristar 727

GOOD

Cobra 148GTL-DX (Early)	Cobra 148GTL-B
Superstar 360	Superstar 360FM (MB chip-version)
Grant (B)	Major M-120 (A)
Superstar 120	Ham International M-788
Ham Int. Multimode 3	Jackson (C)

EXCELLENT

Cobra 148GTL-DX (Late)	Superstar 360FM (145106-PLL)
Marko CB-4444	GlobePhone GS-480DX
Sommerkamp TS-340DX	Superstar 120FM

Lacking the following to be rated as excellent: ()

A - SWR Meter

B - SWR Meter, and different PLL Chip

C - SWR Meter, and Hi/Low RF power switch.

"Edited" EXPORT ROUNDUP

Export List has been edited to those with specifications only.

All others have been dropped - See Vol. 19 for complete list as of
it's publication date.

UNIT	LINE-UP PRINTED	SCHEMATIC PRINTED	OWNER'S MAN. ON FILE.....	VOLUME INDEXED
Cobra 148GTL-DX (Early) 120 Ch. AM/FM/SSB/CW 26.515-27.855MHz, 8719-PLL	V-16	V-19		X
Cobra 148GTL-DX (Late) 120 Ch. AM/FM/SSB/CW 26.515-27.855MHz, MC145106P-PLL	V-17	V-19		X
Palomar 2400, 240 Ch. AM/FM/SSB/CW 26.065-28.755MHz, 02A-PLL	V-18	V-17	X	X
Commtron XII, 120 Ch. AM/FM 26.515-27.855MHz, LC7120-PLL	V-18	V-17	X	X
Colt 510, 120 Ch. AM/FM 26.515-27.855MHz, LC7120-PLL	V-18	V-17	X	X
Lafayette 1800, 200 Ch. AM/FM/SSB/CW 25.965-28.005MHz, 02A-PLL			X	X
Super Star 2000, 200 Ch. AM/FM/SSB/CW 26.065-28.305MHz, 02A-PLL (See note #1)			X	X
Super Star 2000, 200 Ch. AM/FM/SSB/CW 25.965-28.005MHz, 02A-PLL (See note #1)			X	X
Cobra 148GTL-B, 60 Ch. AM/SSB (120 ch. ?) 26.315-27.605MHz, 02A-PLL (See note #2)		V-17	X	X
Tristar 747	V-19	V-15		X
Cobra 150GTL				X
Stalker 9FM, 80 Ch. AM/FM/SSB 26.965-27.855MHz, MB8719-PLL (See Vol. 15)				X
Colt 320FM	See 747 Tristar			
Stalker ST-9FDX, 80 Ch. AM/FM/SSB; and UK-FM 26.965-27.855MHz (UK-FM 27.60125-27.99125) 8719-PLL		V-19		X
Colt 2400, 240 Ch. AM/FM/SSB/CW 26.065-28.755MHz, 02A-PLL			- - - Identical to Palomar 2400 - - -	X
Falcon 2000	See 747 Tristar			
Midland 2001 (Export), 120 Ch. AM-Only (Line-up identical to Colt 510, less FM okts.) 26.515-27.855MHz, LC7120-PLL	V-18	V-19	X	X
Pacific SSB 800, 80 Ch. AM/SSB 26.965-27.855MHz, MC145106-PLL		V-19	X	X
Superstar 95, 120 Ch. AM 26.515-27.855MHz, uPD2810-PLL		V-19	X	X

EXPORT ROUNDUP (Cont.)

<u>UNIT</u>	<u>LINE-UP PRINTED</u>	<u>SCHEMATIC PRINTED</u>	<u>OWNER'S MAN. ON FILE.....</u>	<u>VOLUME INDEXED</u>
Ham International Concorde II	See 747			
	Tristar			
Hygain V (Export)	See 747			
	Tristar			
NATO 2000, 200 Ch. AM/FM/SSB/CW; and U.K.-FM 26.065-27.855MHz (FM-27.60125-27.99125MHz)			X	X
Thunder 2000, 240 Ch. AM/FM/SSB/CW 26.065-28.755MHz, 02A-PLL	- - - Identical to Palomar 2400 - - -			
Teaberry Stalker XX (FM), 80 Ch. AM/SSB/FM 26.965-27.855MHz, (MB8719-PLL)				X
Lafayette 2400, 240 Ch. AM/FM/SSB/CW 26.065-28.755MHz, 02A-PLL	- - - Identical to Palomar 2400 - - -			
Super Star 360, 120 Ch. AM/SSB/CW 26.965-27.405MHz; 28.000-28.940MHz (MB8719-PLL)	V-18		X	X
Super Star 360FM, 120 Ch. AM/FM/SSB/CW 26.965-27.885MHz; 28.500-28.940MHz (MB8719-PLL)				X
Major M-120, 120 Ch. AM/FM 26.965-28.305MHz, 02AG-PLL	V-19		X	X
Grant-DX, 120 Ch. AM/FM/SSB 26.515-27.855MHz, MB8719-PLL	V-19		X	X
Marko CB-444, 120 Ch. AM/FM 26.965-28.305MHz, 02A-PLL	V-19		X	X
Tristar 727, 120 Ch. AM/FM 26.965-28.305MHz, uPD2810-PLL	V-19		X	X
Jackson, 226 Ch. AM/FM/SSB 26.065-28.315MHz, MC145106-PLL	V-19		X	X
Super Star 360FM, 120 Ch. AM/FM/SSB/CW 26.515-27.855MHz, MC145106-PLL (See note #1) - - - Identical to 148GTL-DX (Late)	- - - Identical to Palomar 2400 - - -			
Ham Int. Multimode 3, 200 Ch. AM/FM/SSB 26.065-28.305MHz, 02A-PLL	V-20		X	X
GlobePhone GS-480 DX, 80 Ch. AM/SSB/CW 26.965-27.405, 27.665-28.105MHz; CCI3001-PLL	V-20	V-20	X	X
Sommerkamp TS-340 DX, 80 Ch. AM/SSB/CW 26.965-27.405, 27.665-28.105MHz; CCI3001-PLL	V-20	V-20	X	X
Palomar 5000, 240 Ch. AM/FM/SSB/CW 26.065-28.755MHz, 02A-PLL	- - - Identical to Palomar 2400 - - -			
Ham Int. M-788, 200 Ch. AM/FM/SSB 26.065-28.305MHz, 02A-PLL	V-20		X	X
Superstar 120, 120 Ch. AM 26.965-27.855, 28.500-28.940MHz; uPD2816C-PLL	V-20		X	X
Superstar 120FM, 120 Ch. AM/FM 26.515-27.855MHz; uPD2816C-PLL				X

NOTE #1: 2 different versions exist!

#2: Called 60 ch., Fo sheet shows 120 chnls. (have been noted coming in either configuration-120 Ch. unit has mod on Tone Sw.)

EXPORTS

HAM INTERNATIONAL MULTIMODE 3, 200 channel-AM/FM/SSB; Freq Range: 26.065 to 28.305MHz. Power Lo/Hi switch: 0.5-4W AM/FM; 1.0-10W SSB, (when switched to HI, speech compressor is in circuit). Chassis does have a few unique features: rear jack for Freq. Counter (will only read in TX), relay switching, Roger Beep switch, and the 'Tune' slides TX/RX +5KHz....but there is also a 'Clarifier' and 'Clarifier Sw.' which allows the RX to be tuned separate +800Hz. As with most HAM units it also has selective call. As usual the junk final - 2SC1969, and no SWR meter....

GLOBEPHONE GS-480 DX, 80 channel, AM/SSB/CW; This unit has 2 different frequency bands: 26.965-27.405MHz and 27.665-28.105MHz. Has more controls/functions than most SSB base stations! RF & Mike Gain controls, extra volume control on mike, NB/ANL/Off sw, and FINALLY - S/RF/MOD/SWR Meter!... Clarifier is dual: +5KHz TX/RX (actually was +8KHz!); +3KHz RX. Final-2SC2312, Driver-2SC2166. ...Note: Unit is modifiable, and plenty of useless switches. Factory RF power specs: 6W-AM, 18W-SSB. Does not come with schematic in the Owner's Manual, but is identical to the Sommerkamp TS-340 DX which has schematic. (See page 59 this volume for skem.) For the price (Averaging about \$200+) retail can't be beat, and modification is simple....

SOMMERKAMP TS-340 DX,Identical to Globephone GS-480 DX.....

HAM INTERNATIONAL M-788, 200 channel, AM/FM/SSB; Freq Range: 26.065 to 28.305MHz. Regular 02A 'mux-xtal' board', but the clarifier only works in RX, and only when 'Clarifier' control is pulled out. (This will have to be re-worked to TX/RX permanent, pull feature on switch can be utilized for something else.) No SWR meter. Roger Beep switch, DX/LOC sw., and an indicator 'Dual Color LED' for letting you know when out of 'CB' band. (Green below Ch.1, Red above Ch. 40). Relay switching and has the typical HAM select call feature, schematic comes with Owner's Manual, ... as does the BUM final....

PALOMAR 5000, 240 channel, AM/FM/SSB/CW; Freq Range: 26.065 to 28.775MHz. Sound Familiar? Yep - Identical to the Palomar 2400 - all they did was put a new glue-on label on front panel. (See write-up, this issue!)

EXPORTS

SUPERSTAR 120, 120 channel-AM Only. Two different Fo ranges: 26.965-27.855MHz, 28.500-28.940MHz. Unit has SWR Meter, Hi/Low Power(7-4W spec.), RF Gain, Mic. Gain, Tone, Bright/Dim, ANL/NB. Final has thick White insulator on it - CHANGE!
(See Tune-up this volume...)

SUPERSTAR 120FM, 120 channel AM/FM; Freq Range: 26.515-27.855MHz. Identical front panel layout as the Superstar 120; with exception of the Bright/Dim; which is now AM/FM sw. Owner's Manual which accompanies unit is not correct, is just 'Rubber Stamped' with FM on the 120 manual. Relay switching, 'Roger Beep', and different final. Has thick White insulator on it also - CHANGE!
(See additional write-up this volume.)

The Stalker 9's (Export Versions) ... the CORRECT STRAIGHT OOP!

STALKER 9FM, 80 channel AM/FM/SSB; Freq Range: 26.965-27.855MHz. MB8719-PLL, No Roger Beep, No SWR Meter. Fo range shift through 2 4-bit adders, not crystals.

STALKER 9FDX, 80 channel AM/FM/SSB, plus 40 channels U.K. FM Band. Freq Range: 26.965-27.855MHz, and U.K. FM 27.60125 to 27.99125. MB8719-PLL, No Roger Beep, No SWR Meter. Fo range shift is also through 2 4-bit adders, no Xtals. A separate small PCB contains the U.K. FM circuitry.

Notes: 9FDX has the 4-bit adders on the channel selector board. 9FM has them on the main PCB. Both units are highly modifiable. See Vol. 15 for 9FM modification. These units do not have the Gold trim that the Teaberry's had, is Silver trim.

The Stalker 9 Elite is a custom unit being built in the U.S., using the 9FM as a building block. Not an Imported 'Export'...

CAUTION: There is a ?-new-? Cobra 148GTL-DX, 240 channel AM/FM/SSB/CW rig out from what I hear. Check before you buy as sounds like a 'Bootleg' unit. Probably a Palomar 2400 that has been 're-labeled' to cash in on the Cobra name.

UPDATE: Cobra 2000GTL-DX ??? There is a U.S. version being "re-worked" adding FM and slide, plus another 40 channels on the up side. Unit seen had all new additional circuitry in a box, which could be mounted? Don't ask where to obtain!!.....

GRANT - TX Power Sw. Mod
by D.G.

1. Rewire ANL/NB or Bright/Dim switch permanently ON (Hardwire point to point on PCB.)
2. Rewire switch as shown below to etch side of PCB. Check to make sure that all pins on switch are isolated.

Push Button switch shown in OUT position, LOW POWER.
GREEN LED should be ON, denote O.K. to use R.F. Amplifier.

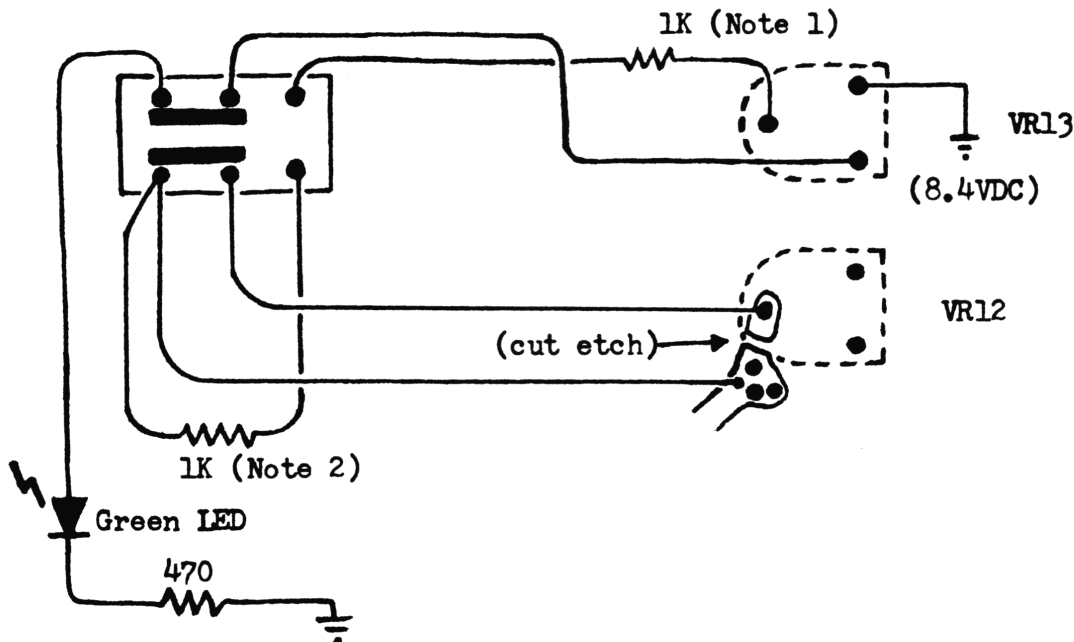

3. Install the Green LED directly above RF/S Meter. (NOTE: Will CAREFULLY have to drill a hole for this.)
4. Switch to OUT position, Green LED - ON! Adjust for following:
VR13 - 3.5 to 3.8W in AM Mode
VR12 - 12 to 14W in SSB Mode. (Maximum Mike Gain)

(All resistors are $\frac{1}{2}$ W 5%).....

Note 1: This value gives 10W AM in High Power. (May be varied to suit your individual needs.)

Note 2: Value gives 25W PEP on SSB. (Also may be varied to suit.)

Remember: Green LED ON - O.K. to use RF Amplifier.

OR Make up a label as below, mount above LED. Use on Jackson too!

C A U T I O N DO NOT TURN ON AMP IF THIS <u>LITE</u> IS NOT ON ↓

Realistic TRC-441 (ZAPPER 9000) Fo Mod.
by J.V.

Zapper Reference Chart says to remove C200 capacitor and install Coax there. I found it necessary to leave C200 in the circuit and solder center wire of Coax to C200 lead next to T110. (I did this on the trace side of PCB, also left the shield disconnected.

VCO - T111 will require adjustment to both upper/lower Fo's. If the Fo's won't come in; replace D118 with a Super Diode; hasn't been necessary with all of these units.

Solid 4W from 26.515-27.855MHz on all units is normal.

Realistic TRC-455 (SM5104-PLL) 26.325-27.405MHz Fo Mod.
by J.V.

Quote: "This was a Butcher-Job rework; starting with another junker to make one good unit; and a few \$\$." Turned out very good with almost flat RF out across entire band.

Fo Mod:

1. Remove jumper from Pin 8 of PLL chip.
2. Isolate Pin 9 by cutting the etch.
3. Cut trace going to Pin 10.

Switch is a 3 position, 3 section slide; wiring diagram below. Use Vol 12, page 30 for lineup.

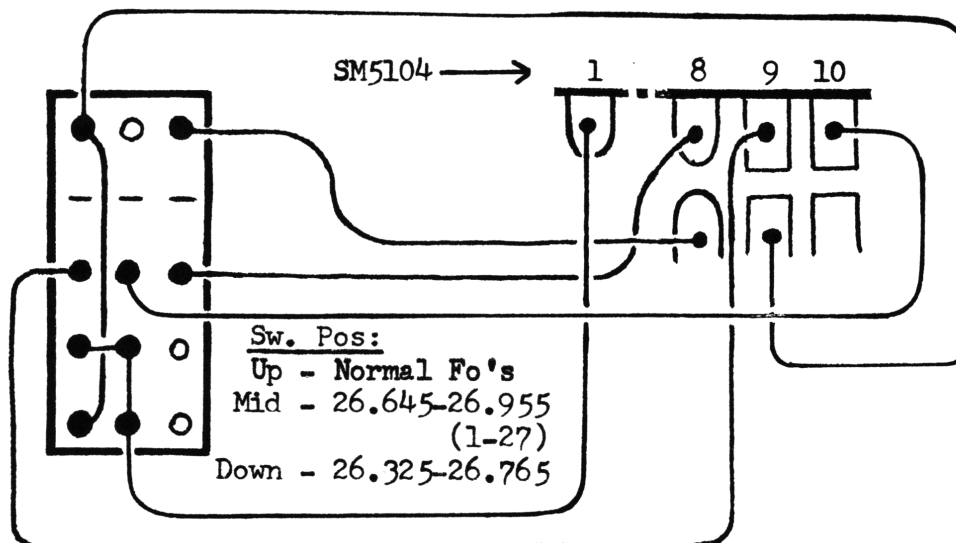

CORRECTION
Completed
7/6 out 8/4

RE: GRANT SLIDE - Vol. 19, page 35-36.

O.K. - Problem cropped up on this one: DELETE STEP 5 V-19, pg.35.

Once over look on complete schematic found the problem with changing the value. Is linearizing resistor for the Clarifier pot. Leave the original resistor in place. Cross step 5 out in your book!

This will solve any problems with modification, as the rest is correct.

GRANT SLIDE - (+3.5KHz. -10KHz) - Tested!
by D.G.

*Use drawing on page 36 of Vol. 19 for reference, if needed.

1. Gray and Blue wires on clarifier pot removed at small PCB.
2. Blue to PCB Gnd., Gray to 8.4VDC common trace at front of main PCB.
3. Remove completely D40, D44, and D45.
4. Place a solid wire jumper between D40 and D44 cathode etch lands.
5. Replace either D40 or D44 with: 1-Super Diode and both choke coils that come with the Grant Slide Kit, wired in series.
6. Counter to TP3, Band-Mid, Mode-USB, Clarifier to 12 o'clock pos., Ch. Sel to 19.
7. Adj I26 for 16.4925MHz or highest possible reading. (Will probably not reach) - bring clarifier up until counter does read 16.4925MHz. Don't move the clarifier until alignment finished.
8. Adj I25 for 16.4900MHz in AM Mode.
9. Adj I27 for 16.4875MHz in LSB Mode.
10. Band to Low, Mode to AM, - adjust I22 for 16.040MHz.
11. Adj I23 for 16.0425MHz in USB Mode.
12. Adj I24 for 16.0375MHz in LSB Mode.
13. Center Fo on all bands should now be at the same point. The only 'problem' if it is - clarifier is usually at 3 o'clock position for center Fo.

NOTE: Actual slide was; (AM, +3.5, -12.0)(USB, +3.0, -10.0) and (LSB, +3.8, -13.5).

Superstar 120AM, Low Fo Mod.
by B.W.

(Use Schematic, page 63 for reference...)

1. Remove X2 (15.360), X3 (15.810), X4 (16.895) - Carefully!
2. Put X3 and X4 in your Goodie-Box!
3. Put X2 in X4's position.
4. Obtain two new xtals - Fo's: 14.460 and 14.910MHz.
5. Put 14.460 in X2's position, and 14.910 in X3's position.
6. Band switch section S206-C must be jumpered as below:

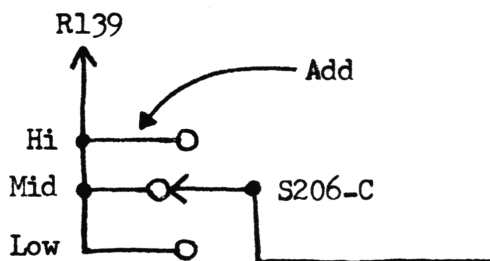

7. Band switch section S206-A must be changed to below:

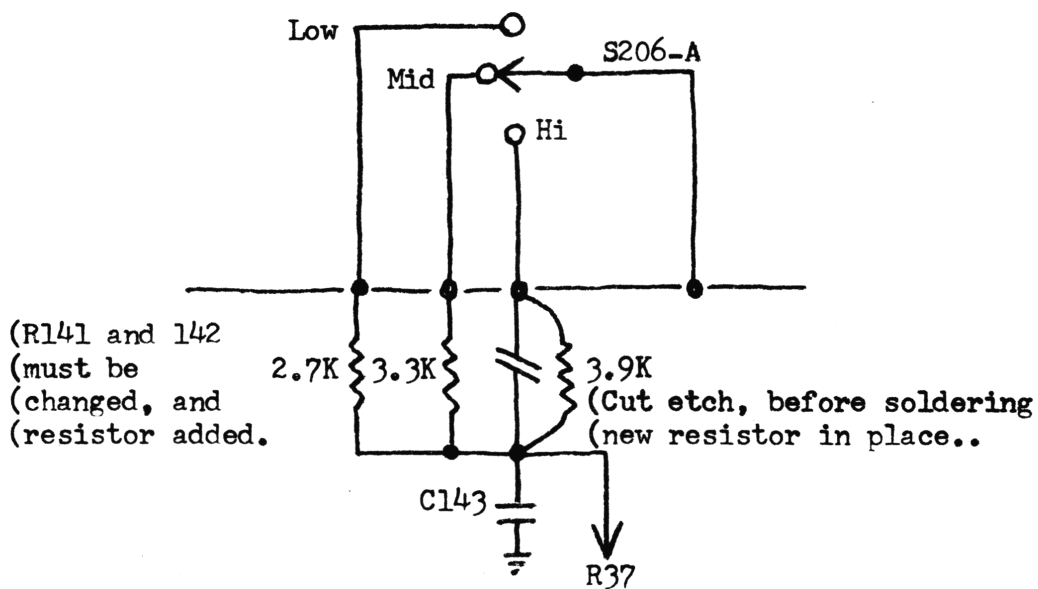

8. With above all done, slight realignment may be necessary to L19, and re-peak of TX/RX circuitry.

New Fo's are now: Low - 26.065-26.505
Mid - 26.515-26.955
Hi - 26.965-27.405

Testing Those "Bulk Pak/Questionable/Unmarked" Zeners.
by B.W.

A lot of different parts companies offer bargains at times on Zeners (50/\$1), etc.

BUT, most are unmarked and questionable, and reject for Q.C. purposes. However can be used if tested and remarked....

The test layout below is one I use for checking out Zeners. I do suggest that you re-test all "Bargain" zeners. Not only for correct voltage; but current stability; or those bargains might turn out to really cost you. \$\$\$.

If any circuit is going to "pull" over 1 amp, make sure that diode is double-checked for 25% more current over spec.

I use two variable 25VDC P/S's hooked up in series, 2A ammeter, and 2 VOM's. Usually can go thru about 40-50 zeners in an hour, on a preliminary checkout. NOTE: Prior to checking any zeners use a VOM, as many are mis-marked!

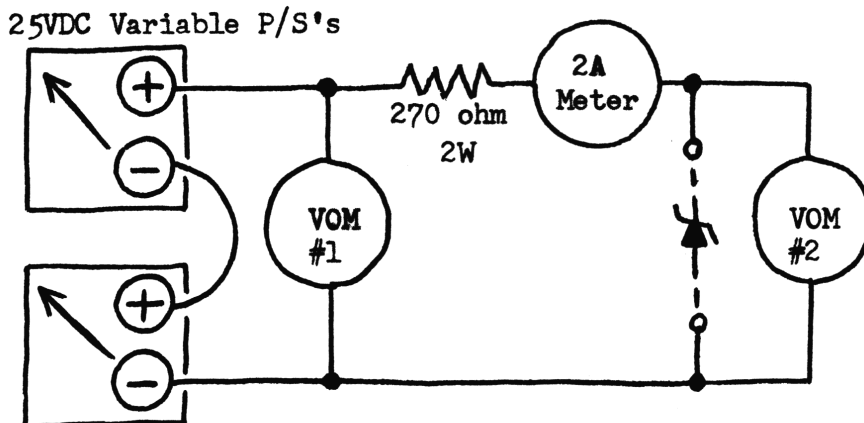

Instructions:

1. Both P/S's to minimum or 0VDC.
2. VOM #1 is used to monitor input voltage - must be a minimum of 25% more than VOM #2's reading. VOM #2 will read the regulated voltage controlled by the Zener in test.
3. Install zener in circuit, and apply voltage slowly.

Test-Zeners (Cont.)...

4. Adjust till the voltage stops on VOM #2.
5. Read ammeter current, if below 250ma - increase voltage input until a minimum of 250ma is achieved.
6. Check voltage stability of zener on VOM #2.
7. Remark or label the Zener if different than marked, after test.

NOTE: Resistor and Ammeter will have to be changed if going to check higher current rated parts.

Have been using this method of checking Zeners for years and had no problems. Just use some caution, always use a higher current zener than specification calls for.

Superstar 120FM, Tune-Up/"Beep Sw" Mod. by D.G.

Quote: "Looks like a Cadillac and about the same comparison as the Jackson for SSB!"

The manual that comes with unit is for the Superstar 120, not the 120FM. Circuitry changes are: PC864AA FM board (has Roger Beep, and Relay switching circuits on it); Xtals are now - X2-14.910, X3-15.360, X4-15.810. Final is 2SC1944 (cross to ECG-236), change the thick White insulator.

Out-of-box operation was 4/8W in Lo/Hi; tuned up to 6/12W; but backed it off to 5/10W. Good forward swing, about 90% modulation.

The correct Fo ranges are: Low - 26.515-26.955MHz
Mid - 26.965-27.405MHz
Hi - 27.415-27.855MHz

"Beep"/Tone Sw. Mod:

1. Trace White wire from VR205 (Mic Gain) to PCB etch. Should also be a Blue wire there going to FM board.
2. Remove the Blue wire from PCB (clean out hole).
3. Resolder Blue wire to un-used side of TONE sw. - center terminal.
4. Solder a new wire from top of same side to the hole cleaned out on the PCB where Blue wire was originally.
5. Switch down - no Beep, Switch up - BEEEEEP....

Special Note on this unit - If you can find Good Luck, is going faster than the Jackson! (Still need schematic, correct one for our files, and also to print.)

JACKSON: Increased Slide & Clarifiers Tied Together.

by D.G.

*This
WORKS*

1. Remove Diode D58 completely from PCB, no replacement.
2. Remove Diode D65 completely from PCB, replace with solid buss wire.
(Both D58 and D65 are located near VR6).

...See drawing below for amplification of next steps...

3. Remove at small switch board the Brown wire going to clarifier 'Fine' control. Connect to 8VDC common, - first trace at front of main PCB. Measure prior to removal in TX/RX mode, to make sure you get the right trace...
4. Remove at small switch board the Blue wire going to clarifier 'Coarse' control. Solder to adjacent connection toward the front of board. Both clarifier knobs to center position.
5. With Band switch in C, channel selector on 20: Connect Fo Cntr to TP3 (R73). Adjust Fo as follows:
AM/FM: L14 - 16.5100MHz
USB: L15 - 16.5125
LSB: L16 - 16.5075
6. The 'Fine' control will now track on both TX and RX, with the following slide ranges:
AM: +9.3, -10.5KHz
USB: +8.0, -9.1
LSB: +10.5, -11.2

"Dotted lines indicate the original wiring, change to solid lines."

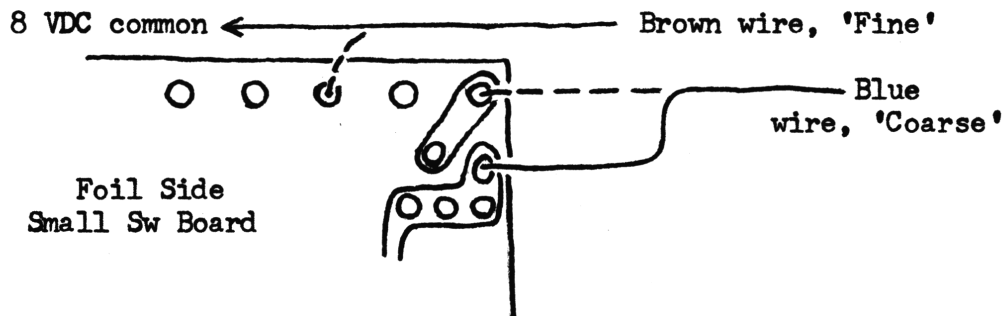

N E E D E D

The following schematics are needed by SCB, for publication.

Must be original, for repro purposes. (Note: Do not send the K-40 SSB schematic if it has the top portion messed up!)

K-40 SSB Uniden PC-44, PC-66, PC-22, PC-9 J.I.L. CD-85CB

These are being requested daily, we do not have on file.....

If an Export schematic has not been printed - we don't have it!

JACKSON: Clarifier Mod.

by G.L.

1. Remove leads from the 'Fine' section of clarifier; (one-by-one); rewire to a R/S #271-227 or equivalent pot. (1K trim pot.)
2. Take the center lead of 'Coarse' control off. Replace on an outer lead of 'Fine' section.
3. Rewire the two remaining leads of 'Fine' section together and run wire to center of 'Coarse' section.
4. Turn both pots dead center, and adjust following for alignment in TX mode (reference: Band D, Ch.10).
 - L14 - AM 27.5250MHz
 - L15 - USB 27.5260
 - L16 - LSB 27.5240
5. The next part is touchy and best tuned with 'known calibrated source'. DO NOT MOVE THE COARSE OR FINE. Make sure that unit is tuned in SSB mode for best audio quality: I used 'On the Air TX' of a Kenwood TS430 and adjusted the 'new' small pot for best audio reception.
6. When finished, tuck/tie the small pot into chassis carefully.
7. Unit now will have 'Fine' adjustment in TX/RX (approx ± 350 Hz), and 'Coarse' will still be the same ± 6 KHz slide.

Use drawing below for amplification of modification:

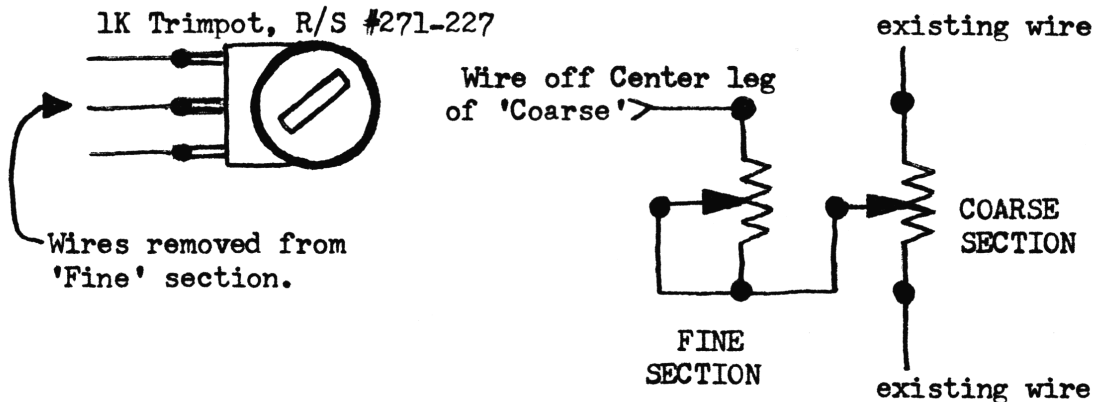

SPECIFIC TUNE-UP

SuperStar 120, 120 Ch. AM (uPD2816C-PLL)

TX-Peak (double-check across the whole Fo band) L18, L17, L16, L11.
RX-Peak L1, L2, L3, L4, L5. VR1-I.F. Gain, VR2-Rx Mtr., VR3-Sq. Rng.,
VR4-Tx Mtr. Final is 2SC1307, but has the thick white insulator-CHANGE!
No AMC control, disable is C65 - if needed. C39 can be increased in
value to make the noise circuitry more efficient.

The Jackson Final: MRF 477

Courtesy "Custom Conversions", may be reprinted.

O.K. - everyone is asking for specifications on this transistor as is causing some trouble... Advice to turn down the AM and SSB power levels has not been heeded, and in most cases max'ed out.

You can rename the transistor 'The Boothill Special', as has put plenty of linear amplifiers in the ground. I know of one particular unit that 'smoked out' a complete company's fleet of linear amps, for 5 notches on the side of case!

Availability of MRF 477 is no problem, standard Motorola RF Line. Specifications are: 40W (PEP) - 30 MHz

RF POWER TRANSISTOR

NPN, Silicon

Low-Cost, Common Emitter TO-220 case.

Specified 12.5 V, 30MHz Performance

Output Power - 40W CW or PEP

Power Gain - 15db Minimum

Efficiency - 40% Minimum (PEP)

Intermodulation Distortion at 40W (PEP)

-30db - maximum

30:1 VSWR Load Mismatch Capability at Rated

Output Power and Supply Voltage

MAXIMUM RATINGS: Collector-Emitter Voltage: 18 Vdc

Collector-Base Voltage: 36 Vdc

Emitter-Base Voltage: 4.0 Vdc

Collector Current, Continuous: 5.0 Amps

Collector Current, Maximum: 8.0 Amps

*Total Device Dissipation: 87.5 Watts

(*) At 25° C - above, derate at 0.5W/degree Centigrade....

Using above is easy to see why they have been going bad, as are operated at near maximum. 10W Deadkey, but when modulation is applied 25+W is not uncommon in AM. In SSB when turned up all the way 60+W, about the norm. Subtract the temperature factor and you can see are asking for trouble....\$\$

Unless you have a pocket full of money/experience/time; adjust the AM power for 15W with modulation applied; and SSB power for 30W. Why support your local transistor distributor?

Transistor lead configuration: Flat side down...

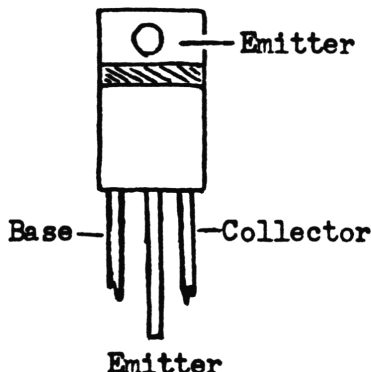

Note: If using with RF Amp suggest turning AM down to 4W with modulation, SSB to 10W....

JACKSON - TX Power Sw. Mod
by D.G.

1. Rewire ANL/NB switch permanently ON (Hardwire point-to-point on PCB).
2. Rewire switch as shown below to etch side of PCB. Check to make sure that all pins on switch are isolated.

Push Button switch shown in OUT position, LOW POWER.
GREEN LED should be ON, denote O.K. to use R.F. Amplifier.

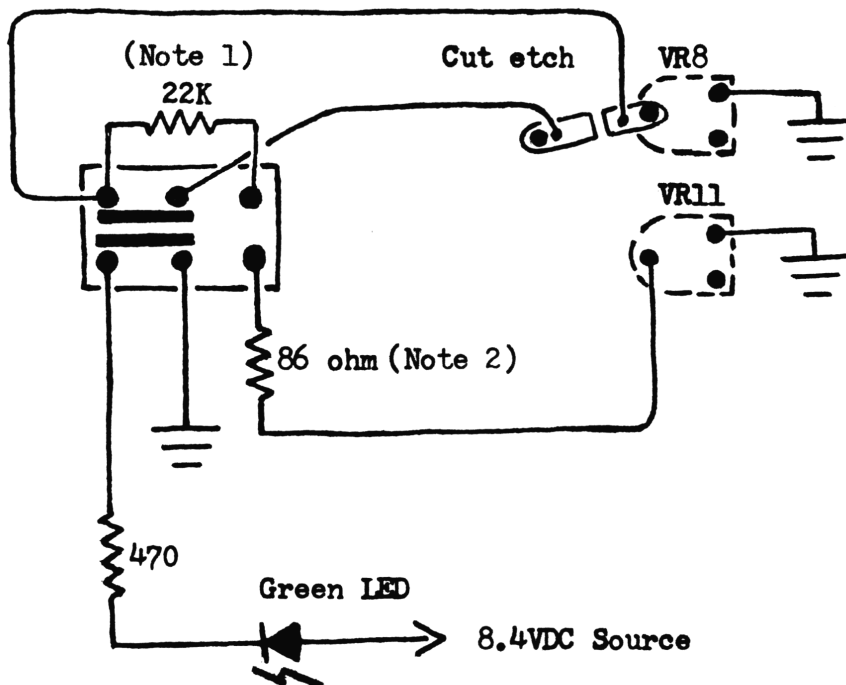

3. Install the Green LED directly above RF/S Meter. (NOTE: Will CAREFULLY have to drill a hole for this.)
4. Switch to OUT position, Green LED - ON! Adjust for following:
VR11 - 3.5W in AM Mode
VR8 - 12 to 14W in SSB Mode. (Maximum Mike Gain)

(All resistors are $\frac{1}{2}$ W 5%).

Note 1: For this value SSB power is max (around 50W PEP).
To lower the high power - reduce value.

Note 2: This value will DEAD KEY approximately 25W AM.
Increase value for lower high power.

REMEMBER: Green LED ON - O.K. to use RF AMP, or you will see RED
and SMOKE....Caution - Hazardous to your wallet \$ \$ \$ \$

JACKSON - Low Fo Mod.
by D.G./B.W.

1. Remove both D26 and D27, replace either one with a 'S-D'.
(Only one is needed.)
2. Hard-wire either the RF/Mod or ANL/NB permanently and use for mod. (Suggest hard-wiring the RF/Mod to RF). CAUTION: Make sure that all pins on the switch are isolated.
3. Isolate Pin 2 of IC7 (Adder), by cutting trace and wiring up as below: Push-Button is shown in OUT position.

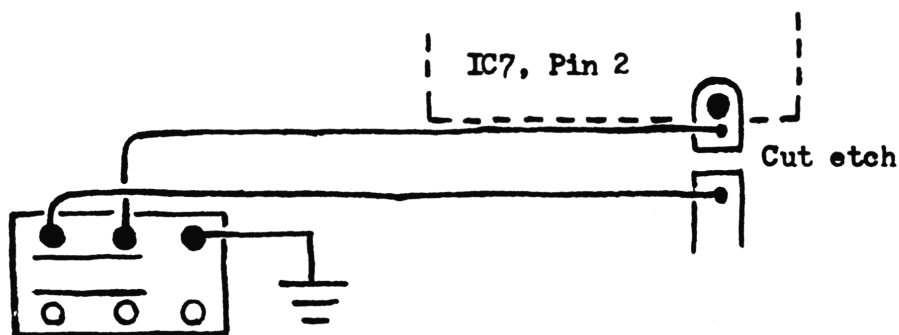

PB Sw shown in OUT position, NORMAL operation/Fo's.

4. Using chart below and L12 bring in the frequencies at this time. Then repeak TX circuits at 26.065MHz for almost linear output. (Note: Will loose some swing on the low end, as much as 30%).

Button IN:

<u>Band - A</u>	<u>Band - A</u>	<u>Band - B</u>
1.... 25.425MHz	21.... 25.675MHz	1.... 25.875MHz
2 25.435	22 25.685	2 25.885
3.... 25.445	24.... 25.695	3.... 25.895
4 25.465	25 25.705	4 25.915
5.... 25.475	23.... 25.715	5.... 25.925
6 25.485	26 25.725	6 25.935
7.... 25.495	27.... 25.735	7.... 25.945
8 25.515	28 25.745	8 25.965
9.... 25.525	29.... 25.755	9.... 25.975
10 25.535	30 25.765	10 25.985
11.... 25.545	31.... 25.775	11.... 25.995
12 25.565	32 25.785	12 26.015
13.... 25.575	33.... 25.795	13.... 26.025
14 25.585	34 25.805	14 26.035
15.... 25.595	35.... 25.815	15.... 26.045
16 25.615	36 25.825	
17.... 25.625	37.... 25.835	
18 25.635	38 25.845	
19.... 25.645	39.... 25.855	
20 25.665	40 25.865	

JACKSON - Lower Fo Mod.
by D.G.

SPECIAL NOTE: UNIT MUST HAVE THE LOW Fo MOD INSTALLED PRIOR TO THIS ONE.

1. With button IN on the prior modification and this additional mod, can obtain coverage down to 25.295MHz.
2. Will have to repeat Step-4 of the Low Fo Mod, in most cases.
3. Open line to Pin 12 of IC5 (PLL), by cutting trace. Option as to which switch to use is up to you. (Try the PA section of the Squelch/PA, as will usually have the Hi/Low Power mod on other Push-Button switch.)

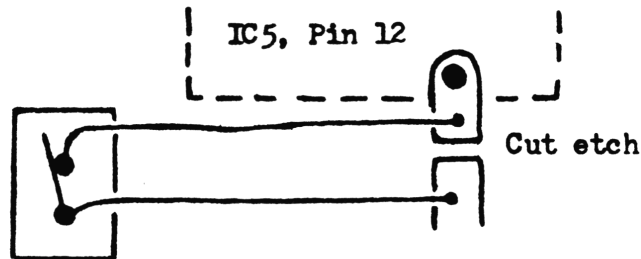

Sw shown in normal condition. Open sw to go lower.

4. With Low Fo mod PB pushed IN; and Lower Fo mod sw opened; the following frequencies will be obtained.

Band A (All mods engaged).

16.... 25.295MHz	22.... 25.365MHz
17.... 25.305	24.... 25.375
18.... 25.315	25.... 25.385
19.... 25.325	23.... 25.395
20.... 25.345	26.... 25.405
21.... 25.355	27.... 25.415

One Sw Arrangement for Low/Lower Fo Mod.

Drawback with this is where to mount, neatly?? Fo's: Up - Normal
Mid - Low; A & B
Down- Lower; A

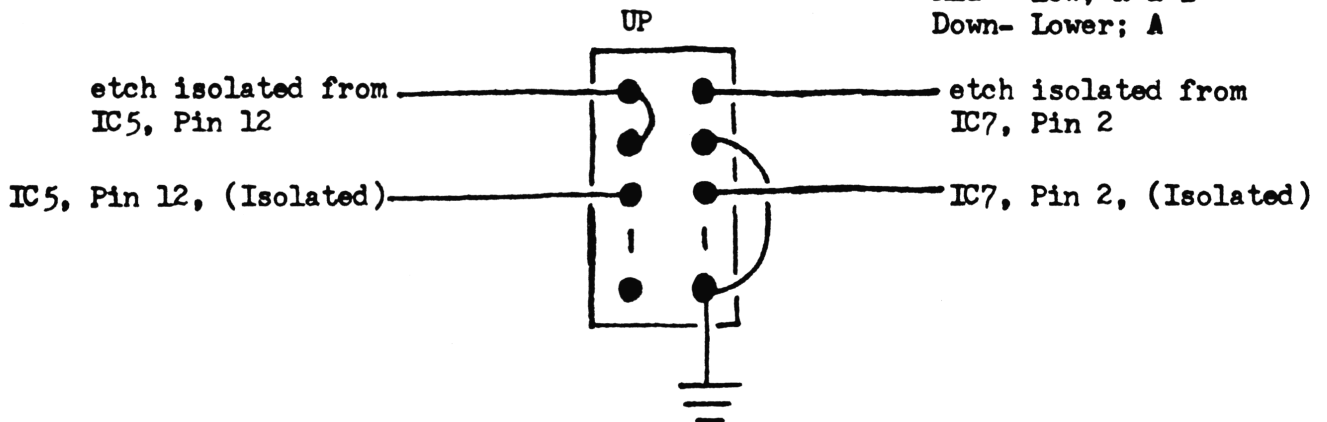

JACKSON: "Quickie" - Fine Tune Unlock
by L.J.

1. Remove D58, no replacement.
2. Remove Brown wire at Fine Tune where it connects to Sw. PCB.
3. Reconnect to cathode D69, wire removed in step 2 realign.

JACKSON: Trouble Spot - I.C.-4 (NJM4558S)
by L.J.

Uniden Part #: 2000-0069

IC4 Voltages with Roger Beep sw. ON.....

<u>Pin</u>	<u>RX</u>	<u>TX</u>
1	8.16	7.75
2	4.44	4.42
3	4.46	4.35
4	4.45	4.28
5	0.0	0.0
6	3.92	3.91
7	8.58	2.73
8	1.37	6.18
9	8.16	7.76

Also TR31 base, should read 0VDC in receive.

JACKSON: Roger Beep - 'ON', Time Change
by L.J.

To change the Beep's ON time only.. The value of R168 (47K), must be changed.....Tests have shown: 68K-extremely short, 56K-about the best, and 39K-loooooong... Or put a variable 100K in place, and adjust to your choice.

EXPORT NOTES

Falcon 2000/Thunder 2000 - Fine Tune Unlock

Feedback on this: Vol. 18, pg. 28 works fine
BUT - Omit step 7.

(Need specs. on both units, PLL chip, Fo Range, Multiplex or Direct - Osc 2 circuits, AM/FM/SSB/CW or what, Roger Beep ?..... Have nothing for sureit does have 02A PLL - FACT.)

JACKSON: Another Sw. Mod, Low/Lowers
by L.J.

Switch is ON-ON-ON type: part # CK7211 or MST205PA.

Following wiring diagram below:

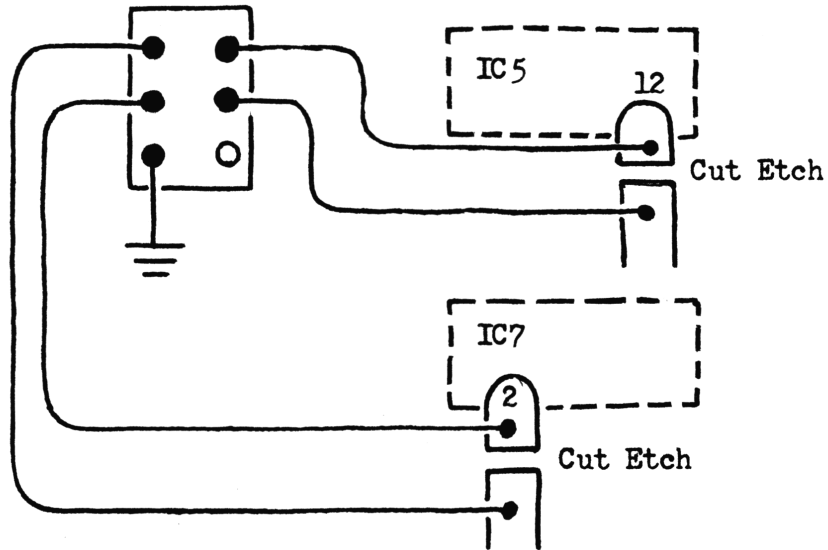

See pages 32 and 33 for frequency chart/selector position.

As wired above, and ground down: Switch Down - Normal Fo's
Middle - Low
Up - Lower

JACKSON - TROUBLE SPOT

I.C.-4 (NJM4558S), Uniden Part # is 2000-0069, cost is about \$3 ea.

Delete (~~ECG cross is ECG-778A, but at about \$5 ea.~~)

Cobra 150GTL - N E E D

Calls abound on this unit for a schematic and copy of Owner's Manual.

SCB has absolutely nothing on this unit in it's files. - Sorry!

If anyone has an original schematic and copy of Owner's manual, would appreciate the loan of it. Hard to believe there are that many inoperative units out ?

GLOBEPHONE GS-480 DX, (Fo Mod)
by M.M.

Quote: "impressed with this unit; the only problem experienced is that if driven too hard in SSB mode will warble; - STOP ALC at 20W PEP with 1KHz tone input!". NOTE: Unit specs call out 6W-AM, 18W-SSB.

The Fo Mod is simple for this unit, an existing switch may be hard wired and utilized for modification. (Try the Ch. 9 sw.).....

Open trace to Pin 11 of PLL by cutting the etch, and wire switch in series across the cut. New Fo's listed below when switch open.

Low Band Selector Pos.	Frequency	High Band Selector Pos.	Frequency
12	27.425MHz	12	28.125MHz
13	27.435	13	28.135
14	27.445	14	28.145
15	27.455	15	28.155
16	27.475	16	28.175
17	27.485	17	28.185
18	27.495	18	28.195
19	27.505	19	28.205
20	27.525	20	28.225
21	27.535	21	28.235
22	27.545	22	28.245
24	27.555	24	28.255
25	27.565	25	28.265
23	27.575	23	28.275
26	27.585	26	28.285
27	27.595	27	28.295

SPECIFIC TUNE-UPS

Kraco KCB 2320

Tune for max forward modulation, L7, L8, and L9 (has 2SC1306 final).
RV1 - Sq Rng, RV2 - AMC, RV3 - RX mtr, RV4 - TX mtr.

Cobra 18LTD

"This unit is a talking fool; keys 7W; with forward drive to about 12W."
VR1-RX Mtr., VR2-Sq. Rng., VR3-TX Mtr. Put a slug into L-9 as has none.
Tune for max forward: L7, L8, and L9. Unit has 2029 final, push it.

MODIFICATION OF EXPORT 02A 5-CRYSTAL CHASSIS TO 25.615-27.855MHz.

by B.W.

Note: This modification will work in any of those chassis which have a 5-Band switch and 5 Crystals in the clarifier circuitry. Most of these units have a frequency range of 26.065-28.305MHz as they come out-of-the-box. The 'E' Band - 27.865-28.305MHz isn't used much; by most individuals; and they want to go lower...

.... For change to 25.615-27.855MHz:

1. Remove crystal X7 (20.555MHz), put in your 'goodie-box' - save!
2. Remove crystal X5 (20.330MHz), put in X7 position.
3. Remove crystal X4 (20.105MHz), put in X5 position.
4. Remove crystal X3 (19.880MHz), put in X4 position.
5. Remove crystal X2 (19.655MHz), put in X3 position.
6. Obtain an 19.430MHz crystal and put in the X2 position.

Realignment of VCO/TX/RX circuitry will be needed in most units; this is no real problem as just shifting the frequency range down; not expanding the bandwidth. (Palomar 2400 alignment may be used AS A GUIDE).

New Fo's per Band Selector:

A	25.615-26.055
B	26.065-26.505
C	26.515-26.955
D	26.965-27.405 (Normal C.B.)
E	27.415-27.855

Below is new Freq. Chart for the A Band ONLY....

<u>Selector</u>	<u>Frequency</u>	<u>Selector</u>	<u>Frequency</u>
1	25.615	21	25.865
2	25.625	22	25.875
3	25.635	23	25.905
4	25.655	24	25.885
5	25.665	25	25.895
6	25.675	26	25.915
7	25.685	27	25.925
8	25.705	28	25.935
9	25.715	29	25.945
10	25.725	30	25.955
11	25.735	31	25.965
12	25.755	32	25.975
13	25.765	33	25.985
14	25.775	34	25.995
15	25.785	35	26.005
16	25.805	36	26.015
17	25.815	37	26.025
18	25.825	38	26.035
19	25.835	39	26.045
20	25.855	40	26.055

02A 'EXPORT' Chassis: "Multiplex and Direct" Band Switching

"Multiplex" chassis: Will have a varied amount of crystals in OSC 2 circuit, a double rotary band switch, and diode matrix in most cases. The FM DET circuit will have only 1 coil.

"Direct" chassis: Will have a separate crystal for every frequency band in OSC 2 circuit. FM DET circuit will have 2 coils.

Below are "Chopped up" partial schematics, but connections are correct.....

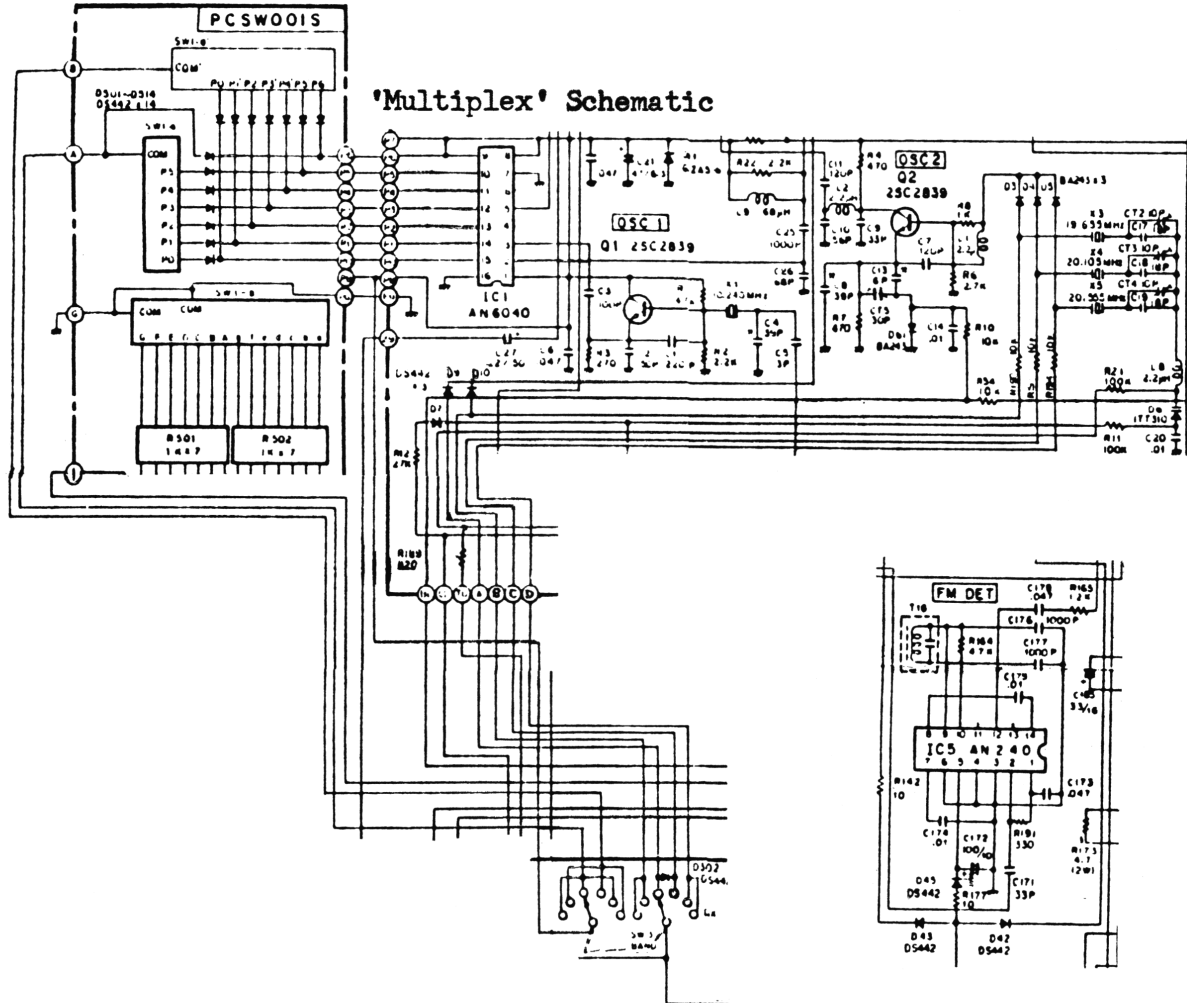

TAKE YOUR CHOICE - WHICH OF THESE WOULD YOU LIKE TO TROUBLESHOOT.....?

'Direct' Schematic

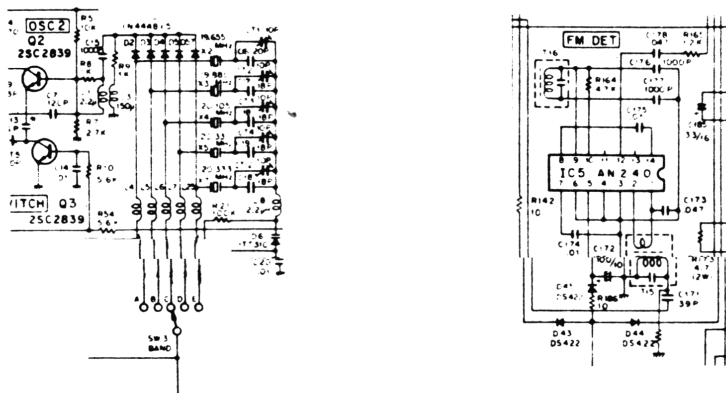

1. RECEIVER

- 1) Set the Mode Switch to AM, Volume Control at maximum, Squelch at minimum and Clarifier in the center.
- 2) Set the SSG on Channel 40 and Channel Selector of the unit on Channel 40.
Then, connect the Power Supply and 8 ohms Dummy Load to the transceiver unit.
- 3) Feed the signal from the SSG and set the audio output for a peak reading by adjusting T-1, T-2, T-3, and T-4.
In this case be sure that antenna input should be less than $1\mu\text{V}$ at the AF standard output power. Also, make sure that the audio on the oscilloscope is a sine wave.
- 4) Set the antenna input at $1\mu\text{V}$ so that the antenna power may be more than 0.5 watt at the maximum volume of all channels.
- 5) Set the antenna input at $1,000\mu\text{V}$ so that the output power should be more than 3.0 watts at the maximum volume.
- 6) Set the antenna input to $50,000\mu\text{V}$ and the low frequency output to 0.5 watt by volume control. Then, decrease the antenna input until the low frequency output stays 10 dB lower. Be sure that the antenna input then should be less than $5\mu\text{V}$.
- 7) Set the antenna input to $100\mu\text{V}$ and the meter indication to 9 by VR-2.
- 8) Set the volume control and squelch control at maximum, and set the tight squelch by VR3 so that the output from speaker is heard when the antenna input is increased upto $1,000\mu\text{V}$.
- 9) Set the antenna input to $0.7\mu\text{V}$ and be sure that the low frequency output should be over 10 dB more when the modulation of the SSG is turned off at the normal output.
- 10) Set the Mode Switch to USB, Volume Control at maximum, Squelch at minimum and Clarifier in the center. Tune off the modulation of the SSG and remove the frequency by 1 KHz.
- 11) Make sure that the maximum sensitivity should be less than $1\mu\text{V}$.
- 12) Make sure of AGC like with AM.
- 13) Set the antenna input to $0.2\mu\text{V}$ and keep the AF output to be over 10 dB lower when the antenna input is turned off at the normal output.

2. TRANSMITTER

- 1) Connection of test equipment.
Power supply at 13.8 VDC.
Connect a Power meter, oscilloscope frequency counter, spectrum analyzer and P-P RF volt meter to the RF output connector.
Connect an AF oscillator and AF volt meter to the microphone connector.
- 2) Power adjustment.
Set the mode switch to AM.
Adjust T-5, 8, 9, L-12, and L-3 for the maximum point.
Adjust L-4 for 3.6W output.
Adjust L-2 to increase 2nd harmonic.
- 3) Frequency-Make sure every channel stays within $\pm 800\text{Hz}$.
- 4) Modulation Limiter Adjustment.
Put in 1KHz and 20mV signal from AF oscillator and adjust VR7 for 90% modulation
- 5) Modulation capability.
Put in 1kHz signal by AF oscillator and get 90% modulation for the minus side. The plus side should be over 80%.
- 6) SSB.
Set the mode switch to USB.
Put in two-tone signal of 1KHz and 1.6KHz by two AF oscillators.
- 7) ALC alignment.
Adjust the two-tone signal of AF oscillator for 3 W RF power output.
Adjust VR-11 for 11 W PEP RF power output when the two-tone signal is increased by 20 dB.
- 8) Carrier suppression.
Cut off the two-tone signal and make sure the output level of the carrier is below -40 dB .
Set the mode switch to LSB and do the same.

GRANT-DX (Fo Mod).
by D.G.

By using just one SPDT-Center Off switch; and a 5.1K 1/4W 5% resistor; can get coverage from 26.335-28.055MHz. Wire up per the diagram below. (See Vol. 19, pgs 34-36; for additional info.)

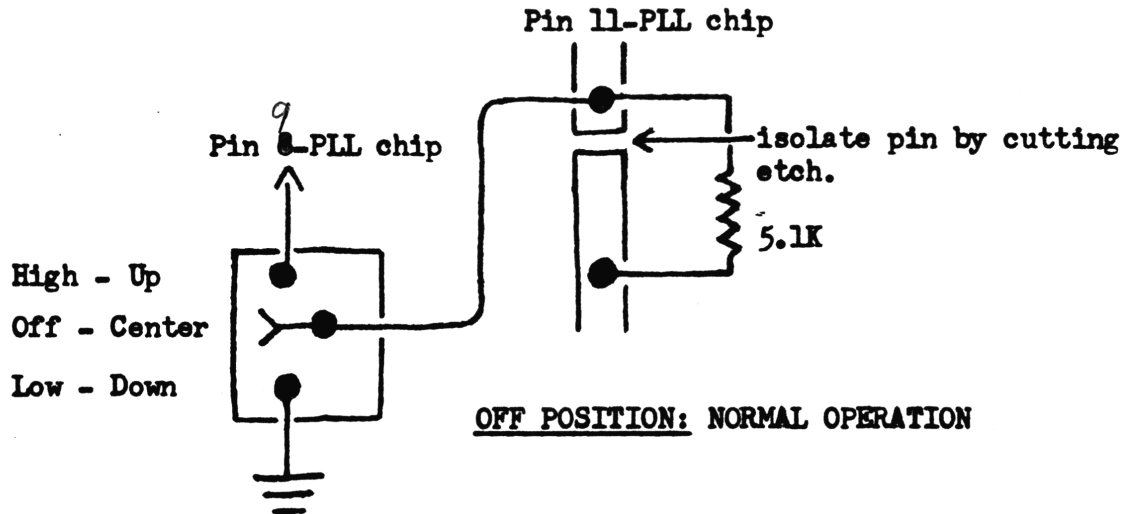

Band Sw. High - Sw. High: 27.865-28.055MHz (Selector: 12-28).
Band Sw. Low - Sw. Low: 26.335-26.505MHz (Selector: 12-27).

Fo Chart:

Band Low/Sw. Low .

12.....	26.335MHz
13	26.345
14.....	26.355
15	26.365
16.....	26.385
17	26.395
18.....	26.405
19	26.415
20.....	26.435
21	26.445
22.....	26.455
24	26.465
25.....	26.475
23	26.485
26.....	26.495
27	26.505

Band High/Sw. High

12.....	27.875MHz.
13	27.885
14.....	27.895
15	27.905
16.....	27.925
17	27.935
18.....	27.945
19	27.955
20.....	27.975
21	27.985
22.....	27.995
24	28.005
25.....	28.015
23	28.025
26.....	28.035
27	28.045
28.....	28.055

Just hard-wire an existing 'useless' switch and install a 3-position slide switch, and you got it.

SPECIFIC TUNEUPS

Midland 13-863B

RV1 - Sq. Rng; RV2 - AMC; RV3 - RX Meter; RV4 - TX Meter.
Tune L7, L8, and L9 for max forward on Ch. 12, has 2SC1306 final.

Pearce Simpson Tiger 23C

AMC defeat - D12; VR3 - TX Mtr; VR4 - Mod Mtr Adj; VR5 - RX Mtr;
VR6 - RF Gain; VR7 - Sq Rng. Tune L4, L5, L8, and L10 for max forward
on Ch 12, unit has 10W final.

Cobra 21 - 23 Ch.

VR1 - RF Gain; VR3 - Sq Rng; VR6 - TX Mtr; VR7 - RX Mtr; AMC defeat D24.
Tune L7, L10, L12, L13 for max forward on Ch. 12, has 2SC1239 final - 12.5W.

Mecca BCB-6, 23 Ch.

No I.D. #'s on board - AMC located, right front of large transformer.

JC Penny 981-6331 - 23 Ch. (No parts ID on PCB - see layout below.)

-NOT TO SCALE, REF. ONLY-

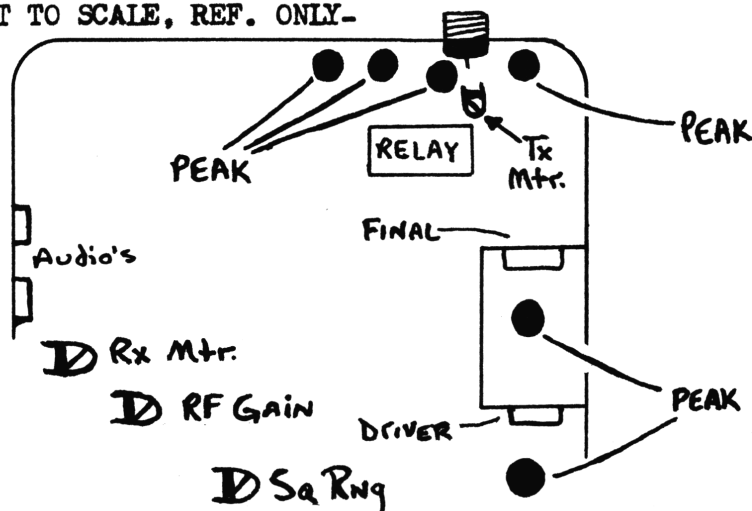

Peak all coils
for max forward
on Ch. 12.
(NO SAMS/SKEM.)
No AMC adjust or
defeat-known.
2SC1306 final,
will have solid 95%
mod. if tuned
right.

Sharp CB700 - 23 Ch. (No parts ID on PCB - see layout below.)

-NOT TO SCALE, REF ONLY..

Peak all coils shown for max forward
on Ch. 12. (AMC is marked Alc on PCB)
Unit has no meter, and no other adjust-
able pots.
"Don't exceed 3½ to 4W with present
Final - it will SMOKE IT!"
Has 2SC1909 final, change it to a
2SC1306.

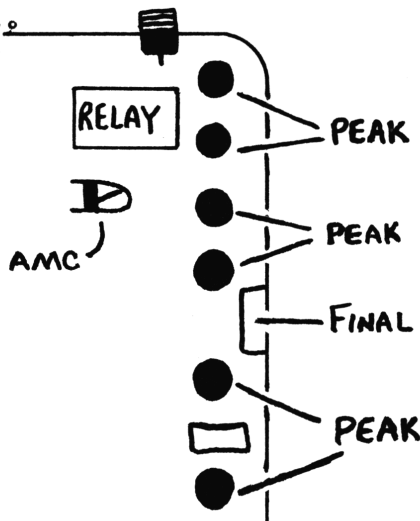

REALISTIC TRC-441 (UPDATE)

Modulation....

Vol. 10, pg 67 - remove D109.... Vol. 11, pg 49 - remove D110....

Both increase the modulation, but by removing D110 the modulation light is also disabled. Take your choice...

COBRA 20LTD/REALISTIC 21-1175 (MIKE WIRING)

R/S, mike leads: White, audio - Pin 1
Red, Tx line - Pin 2
Shield & Blue, both to Pin 3
- Pin 4 (NO CONNECTION)
Black, Rx line to Pin 5

NO INTERNAL CHANGES TO MIKE. CAUTION - If mod limiter has been removed go easy on the mike gain, as will overdrive/distort....

REALISTIC TRC-57 (Low and RC Fo Mod.)

O.K. - this one works!

1. Remove Blue wire on PLL cage, wire up a SPST switch. (A switch)
2. Remove White/Red wire on PLL cage, wire up a SPST switch. (B switch)

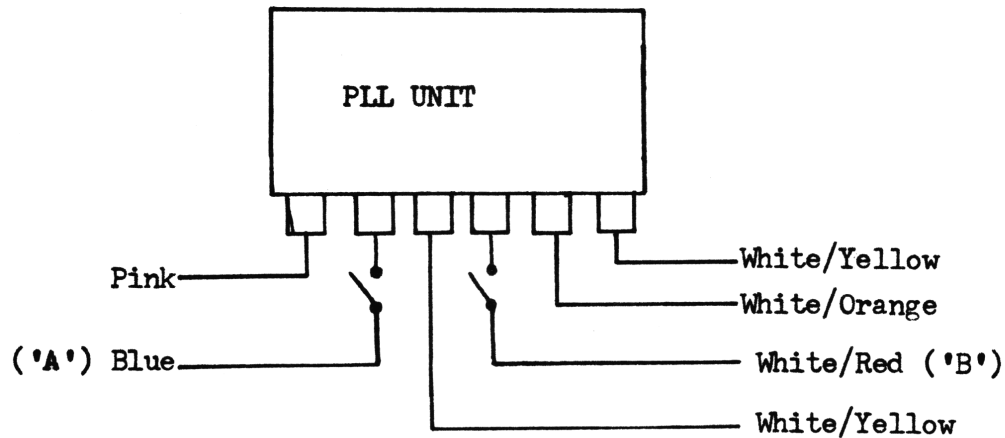

Switch A--Open

10 - 26.875
11 - 26.885
12 - 26.905
13 - 26.915
14 - 26.925
15 - 26.935
16 - 26.955

Switch B--Open

1 - 26.945
2 - 26.915
3 - 26.925
5 - 26.995 (3A)
9 - 27.045 (7A)
13 - 27.095 (11A)
17 - 27.145 (15A)
21 - 27.195 (19A)
23 - 27.235 (Channel 24)

JACKSON LINE-UP PROCEDURE

This is JACKSON (EXPORT), FACTORY Alignment Procedure; re-written slightly for the experienced technician. Courtesy 'Custom Conversions'.

Equipment Suggested: Audio Generator; RF VTVM; DC Power Supply (*); Freq. Counter; Oscilloscope; RF Wattmeter & Dummy Load (50W minimum); RF Sig. Gen. (capable of 1KHz at 30% mod-AM, 1.5KHz deviation at 1KHz-FM); VOM-20K ohm/V min.... (*)-Varies per unit, suggest 7A minimum, REGULATED.

PLL ALIGNMENT (Use Locator A)

Pre-set conditions: Mode - AM Clarifier(both) - Center
 Band - C Power Supply - 13.8VDC
 Ch. Selector - 19 PA/CB - CB

(Do not change any conditions unless specified.....)

STEP	SETTING CHANGE	CONNECTIONS	ADJUST	DIRECTIONS
1.	RX Cond, E Band, Ch-40, AM/FM	DC VOM to TP-2, (lead of R122)	L12	Adjust so that the VOM will indicate 6.0VDC ± 0.1 at E Band Ch-40. Check A Band Ch-1, should be approx. 2V.
2.	RX Cond, C Band, Ch-19, AM/FM	Scope to TP-3, (lead of R73)	L13	Adjust for maximum indication on scope.
3.	Same as above	Freq. Counter to TP-3 (lead of R73).....	L14	Adjust for 16.490MHz, ± 20 Hz.
4.	RX Cond, C Band, Ch-19, USB	Same as above	L15	Adjust for 16.4925MHz, ± 20 Hz.
5.	RX Cond, C Band, Ch-19, LSB	Same as above	L16	Adjust for 16.4875MHz, ± 20 Hz.
6.	Same as above	Freq. Counter to TP-4 (lead of R104).	L24	Adjust for 10.6975MHz ± 20 Hz.
7.	RX Cond, C Band, Ch-19, USB	Same as above	L23	Adjust for 10.6925MHz ± 20 Hz.
8.	TX Cond, (Make sure Dummy Load is connected).. C Band, Ch-19, AM....	Freq. Counter to TP-5 (lead of R82).	L22	Adjust for 10.695MHz ± 20 Hz.



End of PLL Alignment.....

TRANSMIT ALIGNMENT (Use Locator B)

Pre-set Conditions: Mode - USB Mic Gain - CW
 Band - C Selector - Ch. 19
 PA/CB - CB *(Dummy Load, Power Meter, and Scope to Antenna Terminal)....

(Do not change any settings unless specified.....)

JACKSON - TRANSMIT ALIGNMENT (Cont.).....

STEP	SETTING CHANGE	CONNECTIONS	ADJUST	DIRECTIONS
1.	TX Cond, C Band, Ch-19, USB, NO MODULATION	Disconnect PC-834AA, connect DC ammeter to TP8(+), TP6(-)	VR10	Adjust for 50ma on ammeter.
2.	Same as above	DC ammeter to TP8(+), TP7(-)	VR9	Adjust for 80ma on ammeter.
3.	TX Cond, C Band, Ch-19, USB mod. input 30mV - 2,400Hz & 500Hz.	Disconnect meter reconnect PC-834AA.	L42, VR8	L42-turn as far down in coil as possible. VR8-turn clockwise.
4.	Same as above	No change	L41, L43, L33	Adjust for max on scope. NOTE: Adjust input level, so output level is less than 25V.
5.	Change to: B Band, Ch-19. TX Cond, USB mod input 30mV 2,400Hz & 500Hz	No Change	L42	Peak at current Fo setting. Re-peak for power output balance A Band, Ch-1 to E Band, Ch-40.
6.	Same as above, but change to: E Band, Ch-19	No change	L30	Adjust for max on scope.
7.	No change	No change	VR8	Adjust for 32.4V on scope.
8.	TX Cond, C Band, Ch-19, USB, NO MODULATION	No change	VR5	Adjust for minimum carrier-leak balance between USB and LSB modes.
9.	TX Cond, E Band, Ch-19, AM mode, NO MODULATION	No change	VR11	Adjust for 10W on Power Meter
10.	Same as above, push button to S/RF.	No change	VR7	Adjust so meter on unit indicates as below. 
11.	Same as Step 9; but put 1KHz at 30mV input.	No change	VR12	Adjust for 90% modulation
12.	Same as above, but change to; C Band, Ch-19, push button to MOD position.	No change	VR3	Decrease input until modulation output is 50%. Then increase by 16db. Adjust meter to indicate as below: 

JACKSON - TRANSMIT ALIGNMENT (Cont.).....

STEP	SETTING CHANGE	CONNECTIONS	ADJUST	DIRECTIONS
13.	TX Cond, E Band, Ch-40, FM Mode, input 1KHz, 30mV	Connect to the RF Output line, Deviation Meter	VR4	Adjust for 3KHz deviation
14.	AM mode, any frequency. ROGER BEEP sw. to ON position NO INPUT MOD.	Remove Deviation Meter...	None	Observe on scope waveform for TX mod when going from TX to RX mode.
15.	TX Cond, C Band, Ch-19, NO INPUT MOD, NO BEEP	No change	VR6	Adjust for 27.185MHz, <u>+</u> 100Hz.
16.	Same as above, but +10KHz Sw. ON.....	No change	None	Check for TX Fo of 27.195MHz, <u>+</u> 100Hz.

End of Transmit Alignment.....

RECEIVE ALIGNMENT (Use Locator C)

Pre-set Conditions: Band - C Selector - Ch. 19
 RF Gain - CW PA/Squelch - Squelch (CCW)
 Clarifier (Both) - Center
 Volume - CW NB/ANL - OFF
 Mod, S/RF - S/RF

RF Sig. Generator to input of antenna connector at C Band, Ch.-19 Fo.
 (All db reference taken directly from generator.)

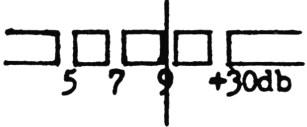
STEP	SETTING CHANGE	ADJUST	DIRECTIONS
1.	Sig. Gen. to: C Band, Ch-19 frequency, 1KHz 30% mod, AM, 500mW level.	L6, L5, L7, L8, L9..	Adjust core of L6 as low as possible. Adjust L5, L7, L8, & L9 for peak indication.
2.	Sig. Gen. to C Band, Ch-1 freq, same level Unit to C Band, Ch-1.	L6	Adjust for peak indication, then turn 1/4 turn CCW.
3.	Sig. Gen. & Unit both to Step 1 setting, CHANGE: No mod., 46db output.....	VR1	Adjust the S meter for indication below: 
4.	Sig. Gen. to 66db +2db, with mod as in Step 1.	VR2	Squelch to CW position, adjust VR2 until opens.
5.	Sig. Gen. to no mod, +20db output C Band, Ch-19. Unit to C Band, Ch-18, USB.....	L3	Scope to lead of D2, adjust L3 for max D.C. voltage, with NB/ANL Sw - ON...

JACKSON - RECEIVE ALIGNMENT (Cont.).....

STEP	SETTING CHANGE	ADJUST	DIRECTIONS
6.	Sig. Gen. to Step 1. Change: FM 1KHz, 1mV, 1.5KHz deviation Unit change to FM.	I4	Tune for peak audio sinusoidal wave.

End of Receive Alignment.....

LOCATORS (Reduced to Scale)

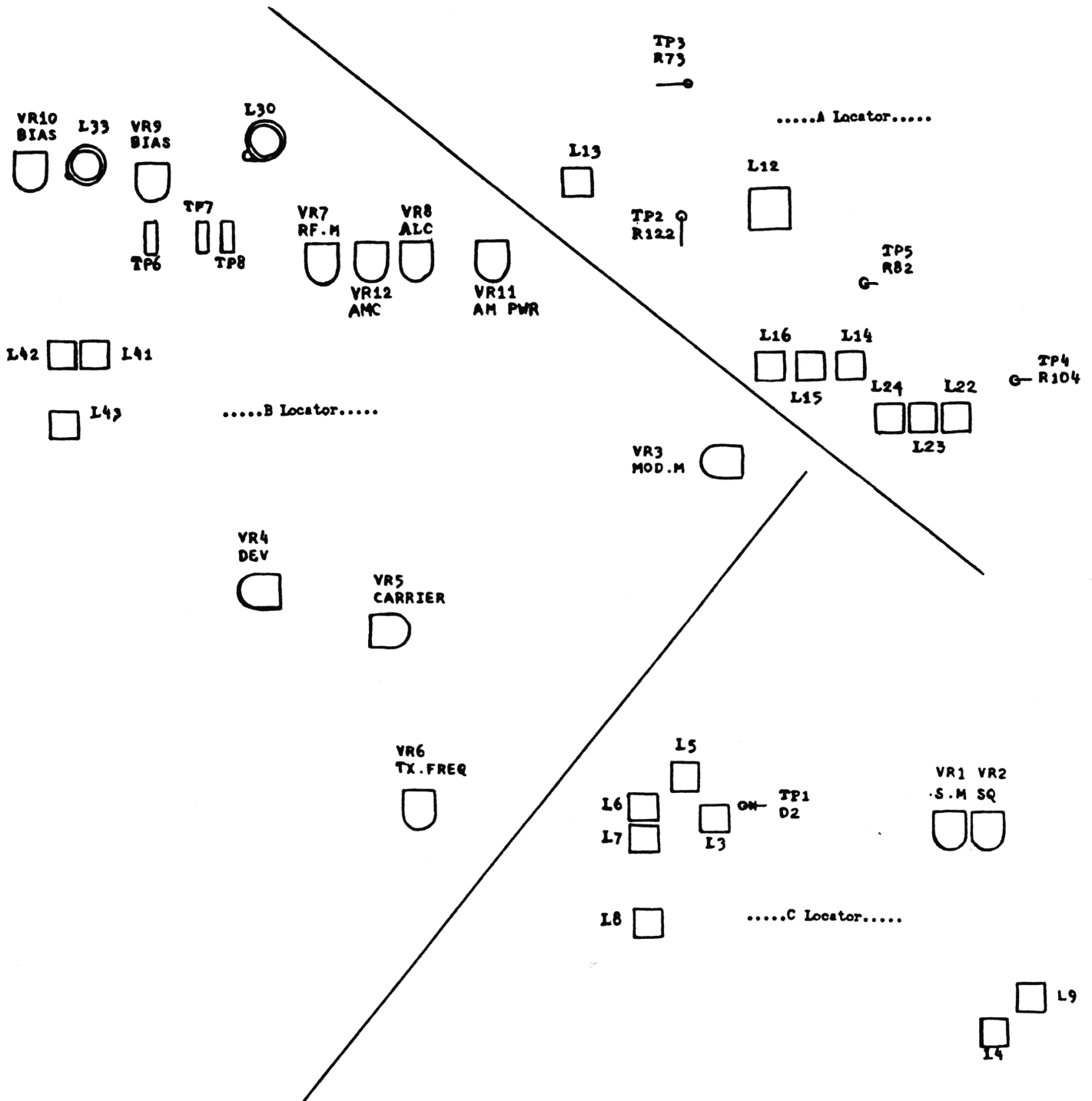

GRANT - PLL ALIGNMENT (Cont.).....

STEP	SETTING CHANGE	CONNECTIONS	ADJUST	DIRECTIONS
15.	RX Cond, LSB Mid Band, Ch-19	Counter to TP-6, (lead of R60)...	L30	Adjust for 10.6975MHz, ±20Hz.
16.	Change to USB, ONLY change...	Same as above	L29	Adjust for 10.6925MHz, ±20Hz.
17.	TX Cond, AM, Mid Band, Ch-19; (Make sure Dummy Load connected.)	Freq. Counter to TP-5 (lead of D52).....	L28	Adjust for 10.695MHz, ±20Hz.

End of PLL Alignment.....

TRANSMIT ALIGNMENT (Use Locator B)

Pre-set Conditions: Ch. Selector - 19 PA/CB - CB
 Mic Gain - CW Band - Mid
 Mode - USB *(Dummy Load, Power Meter,
 and scope to antenna term.)

(Do not change any setting unless specified.....)

STEP	SETTING CHANGE	CONNECTIONS	ADJUST	DIRECTIONS
1.	TX Cond, Ch-19, Mid Band, USB; NO MODULATION	Disconnect PC- 834AA, connect DC ammeter to TP9(+), TP8(-)	VR11	Adjust for 50ma
2.	Same as above	DC ammeter to TP9(+), TP7(-)	VR9	Turn VR10 fully CCW. Adjust VR9 for 40ma.
3.	Same as above	Same as above	VR10	Adjust for 80ma
4.	Same as above; Mod input: 30mv 2,400Hz & 500Hz	Disconnect DC ammeter, put PC-834AA back.	L46, VR12	Adjust L46's core as down as possible. Turn VR12 CW.
5.	Same as above	No change	L45, L48, L49	Adjust for max on scope. NOTE: Adjust input level, so output level is less than 25V
6.	Same as above; Change to: HI Band, Ch-40	No change	L46	Peak at HI Band, Ch-40, then adjust for balanced output from LOW Band, Ch-1.
7.	TX Cond, Ch-19, Mid Band, AM, Mod input: 1KHz 90%	No change	L37, VR13	Adjust both for max on scope.
8.	TX Cond, Ch-19, Mid Band, USB; Mod input: 30mv 2,400Hz & 500Hz	No change	VR12	Adjust for 32.4V on scope.

GRANT - TRANSMIT ALIGNMENT (Cont.).....

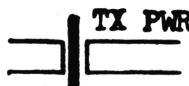
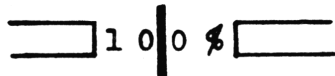
STEP	SETTING CHANGE	CONNECTIONS	ADJUST	DIRECTIONS
9.	TX Cond, Ch-19, Mid Band, USB; NO MODULATION	No change	VR7	Adjust for minimum carrier leak when switching from USB to LSB
10.	Same as above; switch to AM	No change	VR13	Adjust for 10W on power meter.
11.	Same as above; push button to S/RF	No change	VR8	Adjust so meter on unit indicates as below. 
12.	Same as above; AM Modulation . input: 1KHz at 30mV.	No change	VR14	Adjust for 90% modulation.
13.	TX Cond, Ch-40, HI Band, FM, Input 1KHz at 30mV.	No change; Hook-up Dev. Meter to RF Output line.	VR5	Adjust for 2KHz deviation.
14.	TX Cond, Ch-19, Mid Band, AM; Mod input 1KHz at 30mV. Push Button to MOD.	No change; Remove Dev. Meter.	VR15	Decrease input until modulation output is 50%. Then increase by 16db. Adjust meter to indicate as below: 
15.	Same as above; Mod input NONE ROGER BEEP-ON	Remove scope at TP-3. Place on RF Output line.	None	Check for scope waveform TX mod when going from TX to RX mode.
16.	TX Cond, Ch-19, Mid Band, AM; Mod input 1KHz at 30mV.	No change	None	Check for no climbing waveform at 70% mod output, may have to adjust input.
17.	Same as above; Change to USB.	Same as above	None	Check 3rd order harmonics. Should be better than 18db.



End of Transmit Alignment.....

RECEIVE ALIGNMENT (Use Locator C)

Pre-set Conditions: Band - Mid Ch. Selector - 19
 MOD, S/RF - S/RF NB/ANL - OFF
 RF Gain - CW Clarifier - Center
 Volume - CW PA/Squelch - Squelch (CCW)

RF Sig Generator to input of antenna connector at Mid Band, Ch. 19 Fo.
 (All db reference taken directly from generator.)

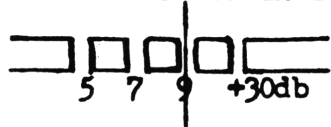
GRANT - RECEIVE ALIGNMENT (Cont.).....

STEP	SETTING CHANGE	ADJUST	DIRECTIONS
1.	Sig Gen to: Mid Band, Ch-19 frequency, 1KHz 30% mod, AM, 500mW level.	L8, L7, L9, L11, L12, L13, L52, L3, L4, & L5.	Adjust core of L8 as low as possible. Adjust L7, L9, L11, L12, L13, L52, L3, L4, and L5 for peak indication.
2.	Change both: Sig Gen and Unit to Mid Band, Ch-1 Fo.	L8	Peak at current setting. Readjust to balance sensitivity between: Mid Band Ch-1 and Ch-40. (Will have to readjust Sig Gen and Unit.)
3.	Unit to pre-set conditions. Sig Gen to Step 1; NO MODULATION 46db output.	VR1	Adjust the S Meter for indication below: 
4.	Same as above; Set Sig Gen to: 1KHz 30% mod	VR4	First turn Squelch CW, then adjust Sig Gen for 66db. Adjust VR4 until Squelch opens.
5.	Change Unit to USB mode. Change Sig Gen Fo to 27.186MHz NO MODULATION.	L14, L15	Peak for max indication.
6.	No Change; set output level to 46db on Sig Gen.	VR2	Adjust the S Meter for indication below: 
7.	No Change; set output level to 66db on Sig Gen.	VR3	First turn Squelch CW. Adjust VR3 until squelch opens.
8.	Set Unit to: Mid band, Ch-18, USB, NB/ANL-ON. Sig Gen - 27.185 +20db output, NO MODULATION. Scope to TP-1, (lead of D2)	L1, L2	Adjust for max indication.
9.	Unit to Mid Band Ch-19, FM. Sig Gen to FM 1KHz, 1mV, 1.5KHz deviation	L6	Tune for peak audio sinusoidal wave.

End of Receive Alignment.....

GRANT - LOCATORS

⊙ R84
TP3

L19
□

.....A Locator.....

R89
⊙ L18
□

R121
⊙ TP4
□

R127
⊙ TP2
□

R60
⊙ TP6

D52
⊙ TP5
□

L27 □ L28 □
L26 □ L25 □
L25 □ L22 □

L30 □ L29 □ L28 □

VR6
⊔

VR11
⊔

VR9
⊔

VR10
⊔

L37
⊙

TP8
⊔

TP7
⊔

TP9
⊔

VR8
⊔

VR12 VR14
⊔ 12 14

VR15 VR1
⊔ 15 13

.....B Locator.....

L46 □ L45 □
L48 □

L49
□

VR1 VR2
⊔ ⊔

.....C Locator.....

L7
□

L8
□

L9
□

L1
□

⊙ TP1-D2

L2
□

L11
□

L12
□

L13
□

R89-TP3
⊙

L52
□

L3
□

L14
□

L4
□

L5
□

L15
□

L6
□

VR5
⊔

VR7
⊔

VR3 VR4
⊔ ⊔

HAM INTERNATIONAL MULTIMODE 3

Schematic Diagram

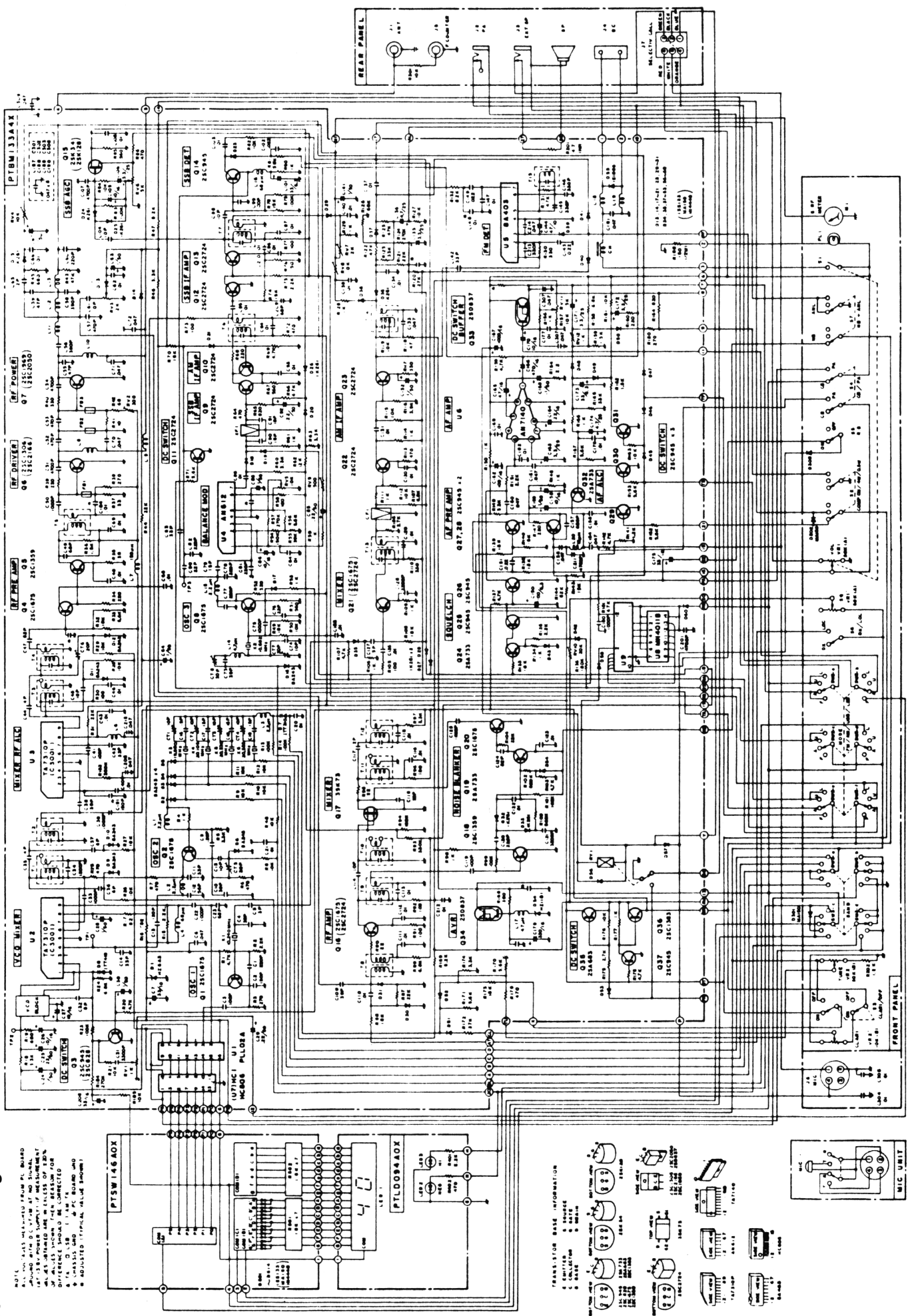

NOTE: ALL VOLTAGE MEASUREMENTS FROM P1 BOARD UNLESS OTHERWISE SPECIFIED. MEASUREMENTS AT 100% POWER UNLESS OTHERWISE SPECIFIED. ALL RESISTOR VALUES ARE IN OHMS UNLESS OTHERWISE SPECIFIED. ALL CAPACITOR VALUES ARE IN P.F. UNLESS OTHERWISE SPECIFIED. ALL DIMENSIONS ARE IN INCHES UNLESS OTHERWISE SPECIFIED. ALL DIMENSIONS ARE IN INCHES UNLESS OTHERWISE SPECIFIED. ALL DIMENSIONS ARE IN INCHES UNLESS OTHERWISE SPECIFIED.

PTSW146A0X

PTLDO8A0X

PTLDO8A0X

PTLDO8A0X

PTLDO8A0X

PTLDO8A0X

PTLDO8A0X

PTLDO8A0X

PTLDO8A0X

PTLDO8A0X

PTLDO8A0X

PTLDO8A0X

PTLDO8A0X

PTLDO8A0X

PTLDO8A0X

PTLDO8A0X

PTLDO8A0X

PTLDO8A0X

PTLDO8A0X

PTLDO8A0X

PTLDO8A0X

PTLDO8A0X

PTLDO8A0X

PTLDO8A0X

PTLDO8A0X

PTLDO8A0X

PTLDO8A0X

PTLDO8A0X

PTLDO8A0X

PTLDO8A0X

PTLDO8A0X

PTLDO8A0X

PTLDO8A0X

PTLDO8A0X

PTLDO8A0X

PTLDO8A0X

PTLDO8A0X

PTLDO8A0X

PTLDO8A0X

PTLDO8A0X

PTLDO8A0X

SPECIFIC TUNE-UPS

Uniden PC-77 (IC7131-PLL)

TX-peak L18, L17, L16, L13. RX-peak L3, L4, L5, L6, L7, L8, (L1 and L2 are noise circuitry adjustment coils—best to leave alone, unless you know how to adjust correctly.) VR1-S Mtr, VR2-Sq Rng, VR3-RF Mtr, VR4-Ant. warning calibration. There is no AMC adjustment: No unit to check this out on but, try removing R138 (100 ohm); only if needed! If noisy and rejection is bad like other models: increase value of C-38 for noise, and add another identical filter in series with FT-2 for rejection.

Realistic TRC-473 #21-1537 (TC9106BP-PLL), another new for '84

Another run-of-the-mill unit (extra's-Tone Control?, RF Gain pot-O.K., and AWL-O.K.). TX-peak L12, L11, L8. RX-peak L1, L2, L3, L4, L5. VR1-S Mtr, VR2-Sq Rng, VR3-RF Mtr, VR4-AMC. If modulation isn't enough remove D18. Increase value of C22 to eliminate noise if a problem.

Uniden PC-55 (TC9106BP-PLL)

TX-peak L14, L15, L12, L11, L8. RX-peak L1, L2, L3, L4, L5. VR1—S Lights, VR2-Sq Rng, VR3-TX Lights. If needed D-13 may be removed for more modulation. (For additional information see Vol. 19 page 40. PC-33 is almost identical unit.)

USACO Md1. U900CB (IC7131-PLL)

O.K.—this is going to be a hit or miss tune-up; as schematic doesn't show what coils are tuneable, and complete owner's manual wasn't sent. (Complete Line-Up is in the manual, along with parts locator!) TX-peak T10, T12, T11, T13, T14. RX-peak T1, T2, T3, T4, T5. VR1-S Mtr., VR2-Sq Rng., VR3-AMC, VR4-TX Mtr. (Mod. disable if needed is C80, 3.3Mf/16V elec.) Final is 2SC2078E; direct replacement is ECG-236; so don't be afraid to push the final.. rated at 20W +

Fieldmaster Micro-Mini 40 (uPD861-PLL)

Don't know where these are coming from - New-in-box? (Were made back in '76 and company is no longer in business.) This is an ideal little unit. TX-peak L15, L13, L10. RX-peak L4, L5, L6, L8, L9. Final is 2SC1678, 10W - so push it. RV1-RF Gain, RV2-Sq Rng, RV3-Rx Mtr, RV6-Tx Mtr, RV401-AMC. Unit does have an outstanding compressor circuit! R53 may be changed to lower value for more drive in the RF power circuitry.---Schematic is on page 57, this volume.

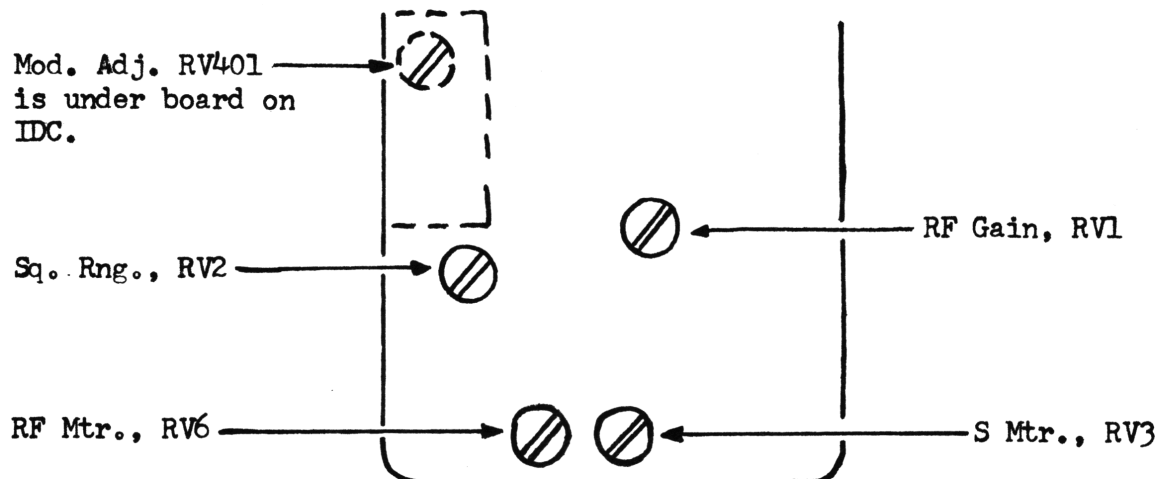

CROSS-REFERENCE

Try SAMS #285, Pace 8093; if in a bind for service data. It is not exact but close for the following: SBE LCMS 4, ROYCE 642. Also may be roughly used as parts locator for the PACIFIC 800 SSB, "have been told is sort of close - better than nothing".

GE 3-5826A SSB Mobile (IC7131-PLL) Slide Mod. by T.J.

No SAMS on this unit...need schematic or Service Manual to copy for our files. (SCB)....

Tune adjustments: AM Power - RV7, ALC - RV2, AMC - RV6, TX Mtr - RV4, RX Mtr - RV3.

No Fo Mod given on this unit - (try Pin 20, logic shift should yield (another 40 upper Fo's - in the 0's. (B.W.)

Slide Mod:

1. Remove D44 from PCB.
 2. Remove D3, replace with a Super Diode, or combination of 'S-D' and Super Slide. (See Vol. 19, page 53.) Will probably need a large slide if you do the above suggested Fo Mod.
 3. Trace White/Pink wire on clarifier control back to PCB, remove at the board carefully. Re-route to positive side of C165 and solder on the etch side of PCB. (If it won't stretch that far, remove at control and use another piece of wire.)
 4. Center clarifier knob and adjust following for center Fo's:
CT1 - USB; CT2 - LSB; CT4 - AM.
-

H E L P

A bunch of the Pacific 800 SSB units are sitting around needing the following parts: IC-1 (SL-1611C), and IC-2 (SL-1612C).

Haven't been able to cross-reference to ECG, etc. Anyone have anything on these 2 chips, pass along the info....

HINTS/KINKS/GOOFS

As usual all information utilized in this column does not receive a free volume. However have reviewed info sent in for use here and put it elsewhere, and many have received the Free-bie! So, keep them coming.....

Pacific 800 SSB: Try using PACE 8093 schematic; SAMS 285; better than nothing at all and close...

9109 Chassis: "spent too many hrs. on this one, no RX. Found 10Mfd Tantalum cap shorted in RX Mixer circuit."

AGAIN-LAST TIME: Check voltage across on/off sw's in RX/TX. Corrosion/Arcing will cause a resistive buildup and drop voltage to unit. 'Will pull a few hairs out trying to troubleshoot a problem, that isn't really there in the circuitry'.

Colt 355: Have found it necessary to replace 10.7 ceramic filter with a 22-39pf capacitor. RX may need slight readjustment afterwards.

GE3-5825B SSB (02A-PLL) Fo/Slide Mod. by M.M.

Slide Modification:

1. Remove D205, no replacement.
2. Remove R221, no replacement.
3. Unsolder and separate the 2 terminals on Clarifier pot that are soldered together.
4. Add wire from end terminal of clarifier pot that has no wire attached to the emitter of Q216. (Voltage source #5.)

Fo Modification:

1. Cut etch feed to Pin 9, bridge with SPST switch.
2. Cut etch feed to Pin 10, bridge with SPST switch.

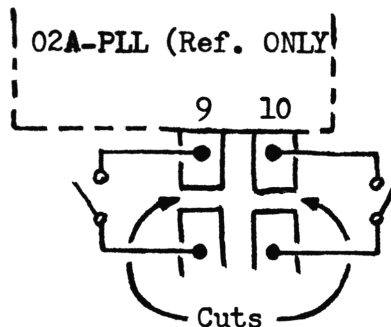

Fo's:

- Pin 9 Open: 27.285 - 27.595MHz; selector position 1-27.
Pin 10 Open: 27.605 - 28.045MHz; selector position 1-40.
Both Open: 27.925 - 28.235MHz; selector position 1-27

MIDLAND 77-830, "Custom Conversion to 26.435-27.405MHz"
by J.V.

Quote: "Reason for doing a write-up on this model is that are popping up from ?.... (New-in-the-box)... Had a hunting club bring in 8 for modification."

A. External Speaker Switch:

1. Remove Pink, Gray, and Purple wires.
2. Delete Pink wire.
3. Solder Gray and Purple wires together, sleeve.
(P.A. and Ext. Speaker are now permanently inoperative.)

B. Filter Switch:

1. Remove Blue/White and Black wires.
 - a. If no filter is wanted - delete both wires.
 - b. For filter, solder both wires together and sleeve.

C. Label switches on front panel:

Ext. Spkr. Switch - Red; Filter - Yellow (Note: I used paint on end of switches.)

D. PLL Mod/Switch Wiring:

1. Cut etch traces to Pins 9 and 10.
2. Bridge the cuts with 4.7K $\frac{1}{4}$ W 5% resistors.
3. Wire up switches as shown below directly to PLL chip pins. (*)

Diagram/Wiring-Step D3

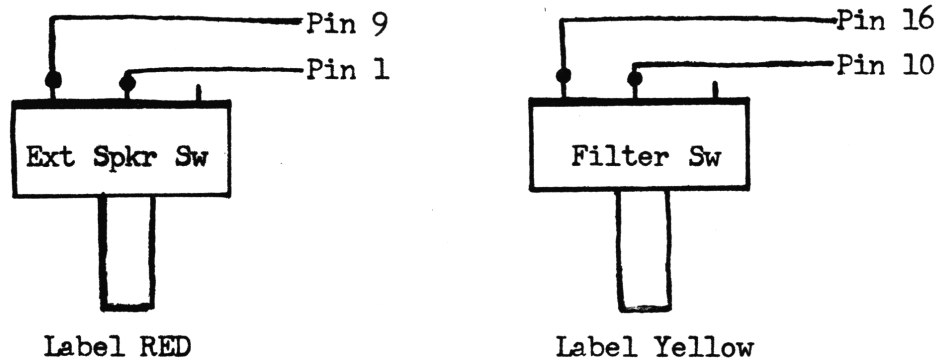

(*) Use Isolated Tip soldering iron...

E. Alignment: See Vol. 16 pg. 24 for alignment techniques.

F. Red switch enabled - 26.435-26.745MHz, selector pos. 10-38...
Red & Yellow switch enabled - 26.755-26.955MHz, selector pos 10-27
26.995MHz, selector pos 31 (3A)
27.045MHz, selector pos 36 (7A)

FIELDMASTER MICRO-MINI 40

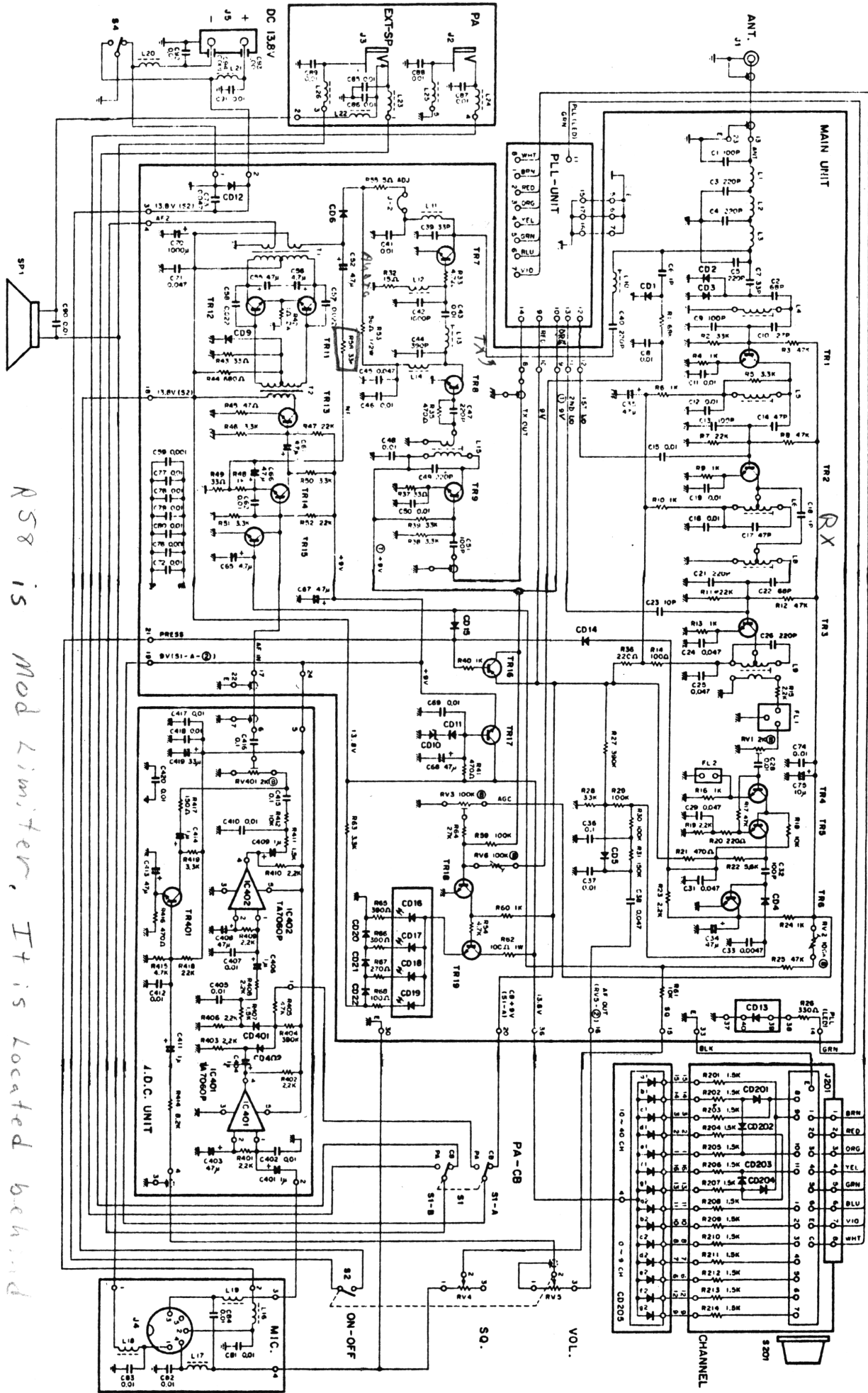

RS8 is Mod Limiter, It is located behind the Ext SPKR and PA SPKR Board.

SOMMERKAMP TS-340DX AND GLOBEPHONE GS-480DX

SCHEMATIC

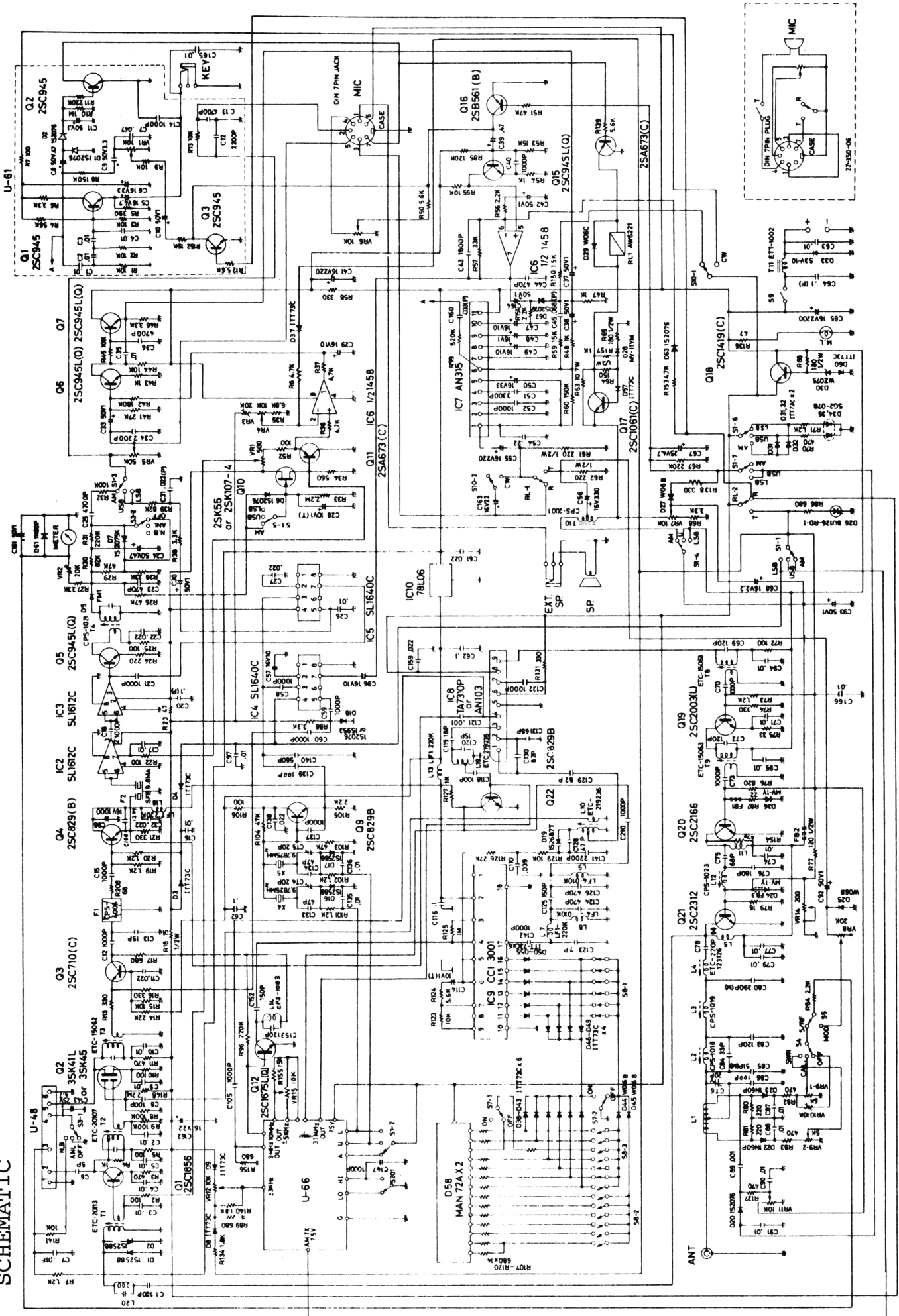

SCHEMATIC DIAGRAM

UNIDEN PC-77

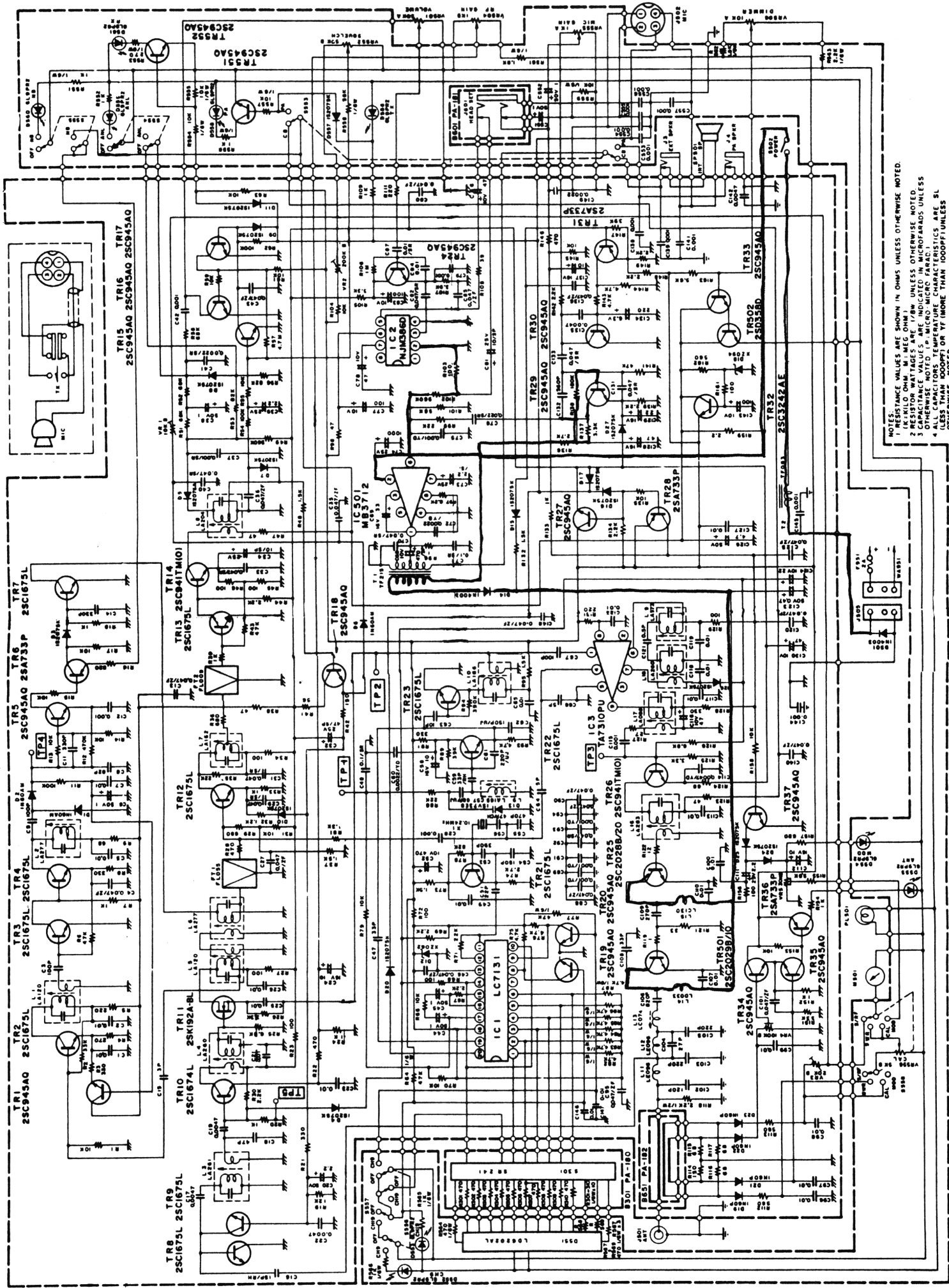

NOTE: RESISTANCE VALUES ARE SHOWN IN OHMS UNLESS OTHERWISE NOTED.
1 (K=KILO OHM, M=MEG OHM)
2 RESISTOR WATTAGES ARE 1/8W UNLESS OTHERWISE NOTED.
3 CAPACITANCE VALUES ARE IN MICROFARADS UNLESS OTHERWISE NOTED.
4 ALL CAPACITORS TEMPERATURE CHARACTERISTICS ARE SL (LESS THAN 100PPM) OR Y (MORE THAN 100PPM) UNLESS OTHERWISE NOTED.

Anc-D13

UNIDEN PC-55 - SCHEMATIC DIAGRAM

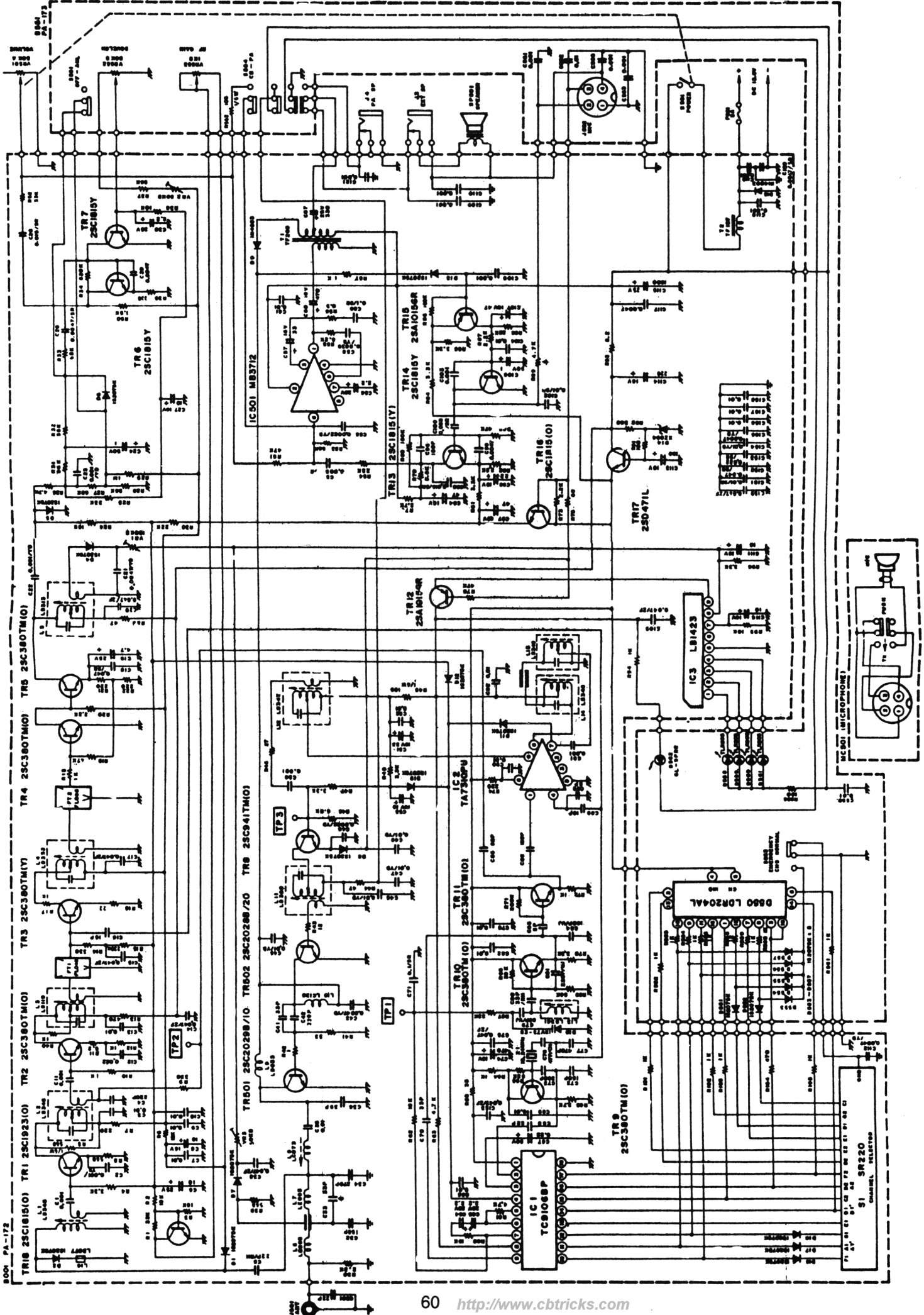

K-40 SSB (IC7131-PLL) Clarifier Mods.

Received two different modifications on this unit, both below:

#1.....by L.S.

- A. Cut PCB trace from RX B+ to VR3-1 and insert 1N4001 in line.
- B. Solder jumper across R125 (22K).
- C. Lift Cathode end of D119 out of circuit and using jumper, attach to cathode end of 1N4001 inserted in Step A.
- D. Clarifier will now shift both TX/RX approx +3.5, -6KHz.

Drawing for #1 mod.

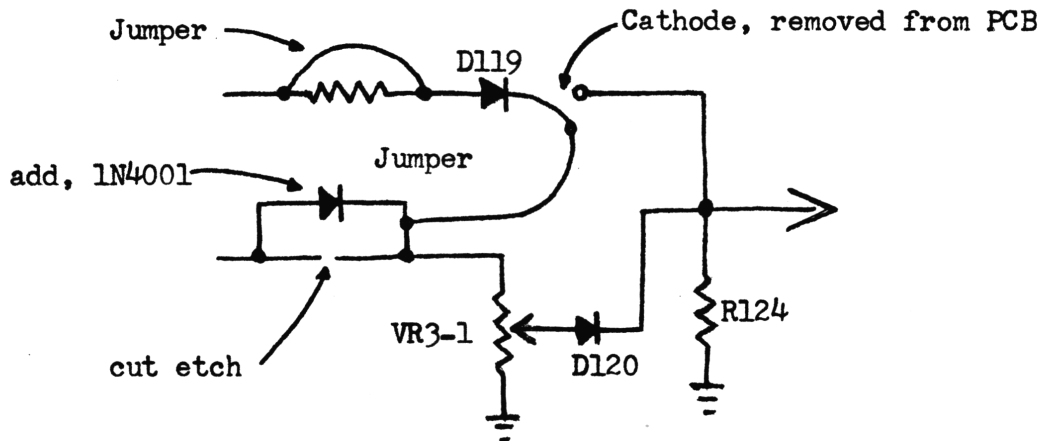

#2.....by C.C.

- A. Cut PCB etch line on RX B+ going to VR3-1. (Isolate the pot's terminal completely).
- B. Run jumper on etch side of board from the emitter of Q401 to isolated terminal of VR3-1. (Emitter Q401 is 9VDC regulated source.)
- C. Remove D119, no replacement.
- D. Remove R124, change to 1K $\frac{1}{4}$ W 5%.

Drawing for #2 mod.

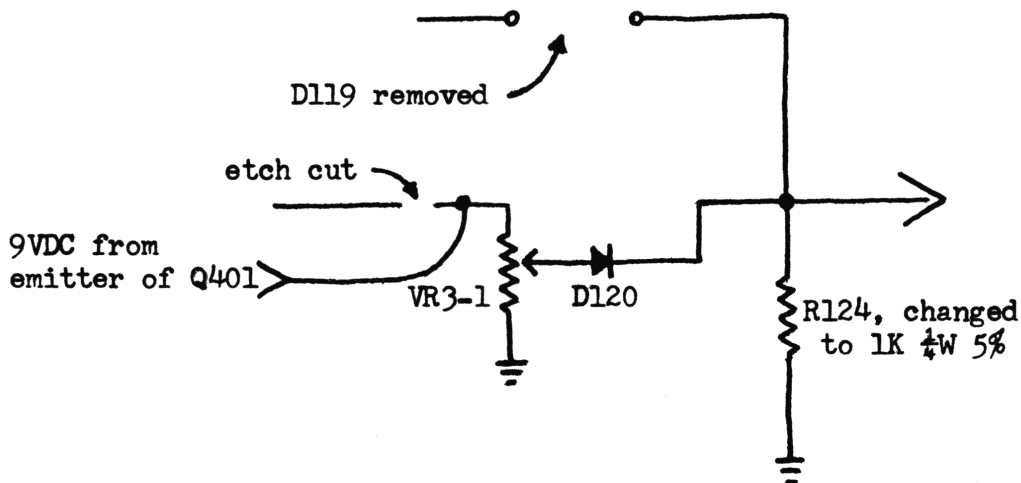

SUPERSTAR 120 (AM/FM) SCHEMATIC DIAGRAM

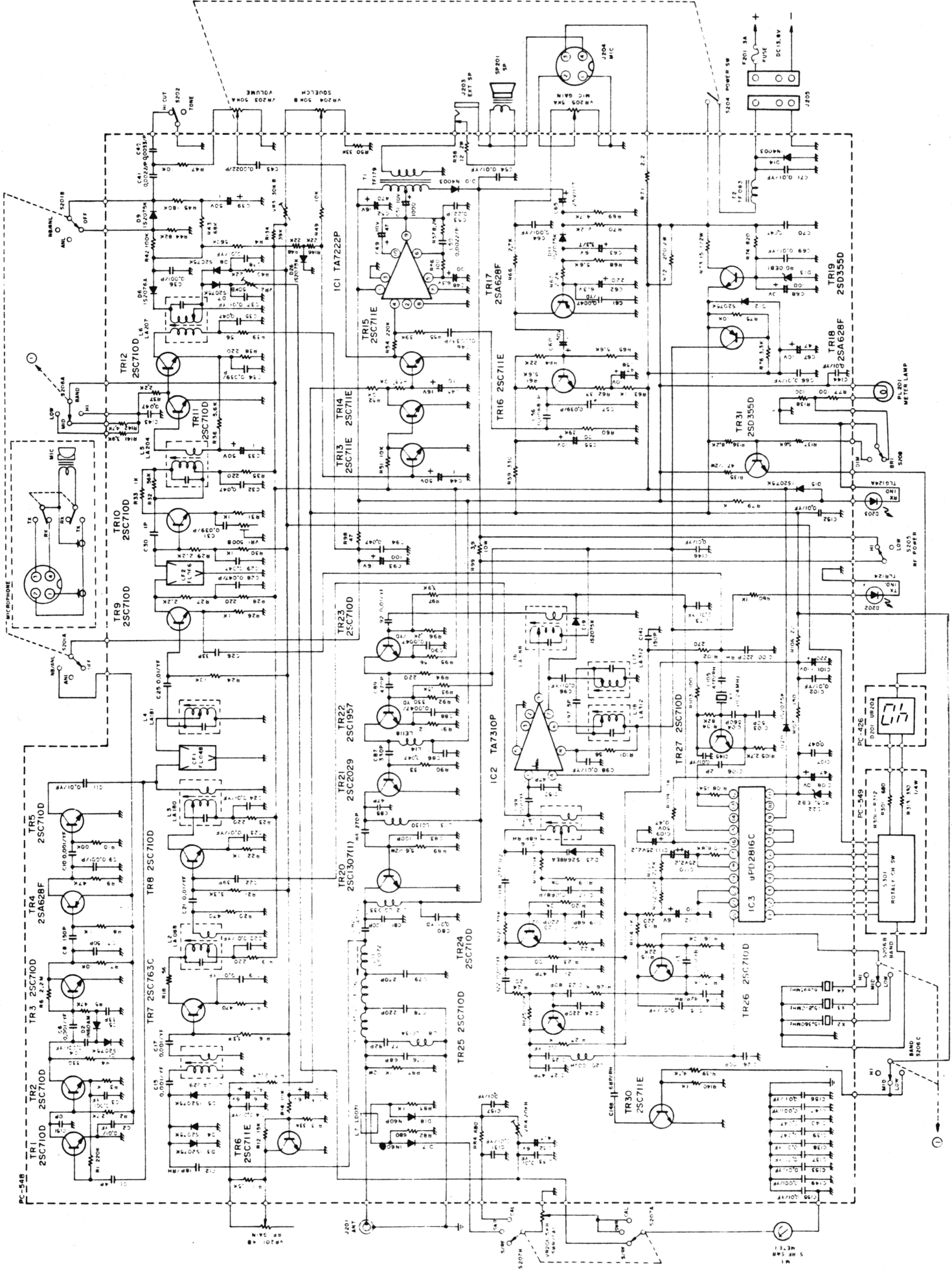

List of EXPORTS that need following information for:

Number of Channels; Transmission Mode (AM/FM/SSB/CW ?); PLL Type;

Frequency Range; Roger Beep ?; and any particulars....

Tristar 747	Cobra 150GTL
Starfire DX	Colt 1600DX
Colt 2000DX	Colt 320FM
Audioline 345	Barracuda GT868
Binatone 5-Star	Colt 295
Cobra 21XFM	Colt 320DX
Colt Excalibur (Export)	Commtron CB40F
Cybernet Beta 1000	Cybernet Beta 2000
Cybernet Beta 3000	Elftone ELCB6000
Falcon 2000	Fidelity CB1000M
Fidelity CB300M	Fidelity CB2000M
Fidelity 2001FM	Great GT858B
Great GT868B	Harvard 400M
Harvard 402MPA	Ham International Concorde II
Hygain V (Export)	Intec 1200FM
Hygain 8795	Ham International Concorde
Jumbo	Lafayette 1200FM
Ham International Multimode II	Major 360
Major M588	Academy 501
Academy 502	Amstrad CB900
Amstrad CB901	Audioline 340
Audioline 341	Harvard 420M
Harvard H401	Harrier CBX
Harrier CBHQ	Halycom Cheetah
Halycom Condor	Ham International 8040
Hygain 80	Hygain 2795
Hygain 2795DX	Johnson XK2000
Lake 850	Lake 950
Lafayette HB870AFS	Maxcom 4E
Maxcom 6E	Maxcom 16E
Maxcom 20E	Maxcom 21E
Midland 2001T	Midland 7001 (Export)
Midland 76-200	Midland 3001
Midland 4001	Mustang CB1000
Mustang CB2000	Mustang CB3001
Nato 40FM	Oscar 1
Petrusse Pacific 160	Radiomobile 201
Radiomobile 202	Rotel RVC220
Rotel RVC230	Rotel RVC240
Sapphire 2000X	Sirtel Searcher
Speedway	Steepletone SCB1FM
Tandy TRC-2000	Tandy TRC-2001
Tandy TRC-2002	Tristar 777
Tristar 797	Transcom CBX2000
Transcom CBX4000	Uniace 100
Uniace 200	York JCP861
York JCP863	Commtron VIII
Colt 870	DNT M40FM
DNT 2740FM	Fidelity CB1000FM
Formac 120	Ham International Hercules FM
Ham International Puma	Ham International Viking

List (Cont.)

Hycom CB2000
Hycom CB4000
Major M540
Midland 150M (Export)
Mongoose 2000
Pearce-Simpson Super Lynx 18
Shogun CB
Stag 357
Vice-President ROY
Tristar 848

Hycom CB3000
Jaws II
Major 3000
Midland 77-FM-005
Multitech MS211
SAM 2000
Sommerkamp TS310DX
Vice-President FRANK
WKS 1001

Those units which we haven't received information on by the time Vol. 21 goes to print, will be dropped from further reference.....Send Manual/Skem, will be returned.

Palomar 5000 (ne: 2400)

This particular unit was sent for evaluation.....

Findings: Owner's Manual - standard sheet for 28.0-29.9MHz unit. Schematic was for a standard 5 crystal 'direct switch' chassis - which was incorrect. This is 4 Xtal mux unit.

Covers pulled for preliminary 'look-see'. Found pliable plastic insulators on all transistors, no heat sink compound. The audio chip was sunked correctly! The Bum final is used still!

Out-of-box operation; RIDICULOUS - for what this unit is supposed to sell for....

Freq.	Power-AM, L/M/H	Power-SSB, L/M/H (USB)
26.065	.75 - 2.5 - 4.5	1.5 - 3.0 - 3.5
26.965	.80 - 2.7 - 4.7	1.0 - 3.1 - 5.1
28.755	1.0 - 3.1 - 5.1	1.5 - 2.7 - 3.5

Of course everything can be turned-up to meet spec., but when you purchase something it should be correct from the start. Not have to pull off the covers and start working on it!

A vast amount of time was spent on this unit's "manufacture" which was evidenced by the glue-on tag under channel selector even had some glue slop. I know they didn't take the time to even put the correct schematic in box.

I didn't spend much time on it either, 15 minutes on bench was about all rig was worth. Covers don't fit tight either and will bow in the middle if screws tightened down.

From what I understand, you can 'custom order' these in quantity with your own Logo/Name on. Be on the look out "Joe's Bar & Grill - DX", they have to get rid of those O2A mux chassis some way!

SATELLITE PROGRAM INFORMATION

We have been asked from time to time about running a list of what is on each satellite.

Below listing is in order of their position in orbit.

Listing according to source is correct at this time (July '84).

SPECIAL NOTE: ... I have been advised that there is no known or available 'Underground' source for "de-scramblers" for: The Fantasy Channel or The Blue Max Theater Channel. (Both are X-Rated...)

SATCOM 5 (AURORA)

POLARIZATION: ODD—Vertical / EVEN—Horizontal

CHANNEL PROGRAM/DESCRIPTION

- 19 OCCASIONAL TRANSMISSIONS—Sports, News, Network Feeds
- 20 LEARN/ALASKA TELEVISION NETWORK—Educational Programming
- 21 OCCASIONAL TRANSMISSIONS—Sports, News, Network Feeds
- 24 ALASKA SATELLITE TELEVISION PROJECT—Independent Programming and Network Feeds

SATCOM F1R

POLARIZATION: ODD—Vertical / EVEN—Horizontal

CHANNEL PROGRAM/DESCRIPTION

- 1 OCCASIONAL TRANSMISSIONS—Sports, News, Network Feeds
- 4 OCCASIONAL TRANSMISSIONS—Sports, News, Network Feeds
- 12 HOSPITAL SATELLITE NETWORK—Professional and Patient Programming
- 13 NASA CONTRACT CHANNEL—Live NASA Mission Events
- 17 NEW ENGLAND SPORTS NETWORK—Regional Sports Programming including Boston's Red Sox and Bruins
- 20 AMERICAN FORCES RADIO AND TELEVISION SERVICE—Independent Programming and Network Feeds
- 22 HI-NET COMMUNICATIONS NETWORK—Holiday Inn Network, includes end to end teleconferencing
- 22 THE FANTASY CHANNEL—Scrambled (Audio & Video) X-rated Programming

SUBCARRIER AUXILIARY SERVICES:

- 20 AFRTS RADIO NETWORK—Independent Programming and Network Feeds

GALAXY 1

POLARIZATION: ODD—Horizontal / EVEN—Vertical

CHANNEL PROGRAM/DESCRIPTION

- 2 THE NASHVILLE NETWORK—18 hrs. of Country-Oriented Entertainment Daily
- 4 THE DISNEY CHANNEL (EAST)—16 hr/day of Family Entertainment
- 6 SIN (National Spanish Television Network)—Spanish Language Movies, Sports, Children's Shows, Comedies, Musicals, and Live Weeknight Newscast from Miami
- 7 CNN (Cable News Network)—Live 24 hour News Coverage, In-Depth Sports, Weather, Financial, Investigative and Feature Reporting
- 8 CNN HEADLINE NEWS—Continuously updated 30 minute wheel of hard news with a 6 minute window for cable systems to insert local news. For the person who wants a quick news fix.
- 11 CBN CABLE NETWORK—Entertainment and information for all family members. Comedies, Westerns, Women's Shows, Daily Movies, Game Shows, Daily TV Magazine Show, Dramas.
- 12 HOME TEAM SPORTS—Regional sports coverage serving the capital region
- 13 C-SPAN—Daily live coverage of the House of Representatives
- 14 THE MOVIE CHANNEL—The first 24 hour, all movie, commercial-free channel
- 15 WOR-TV (New York Channel 9)—New York's independent station featuring sports, movies and oldies.
- 19 CINEMAX (East)—24 hour, commercial free, variety movie channel
- 20 GALAVISION—Spanish language programming offering first run films, specials and sports
- 23 HBO (East)—The industry's most popular full service movie, sports and entertainment channel
- 24 THE DISNEY CHANNEL (West)—Same as Disney (Ch. 4)

SATCOM F3

POLARIZATION: ODD—Vertical / EVEN—Horizontal

CHANNEL PROGRAM/DESCRIPTION

- 1 NICKELODEON—Programming for pre-school through teenage audiences
- 1 ARTS & ENTERTAINMENT (Alpha Repertory Television Service)—Fine Arts presentations
- 2 PTL (People That Love)—24 hour religious programming
- 3 WGN-TV (Chicago Channel 9)—Chicago's Independent Station featuring movies, sports, specials and syndicated programs
- 4 FNN (Financial News Network)—Live Business and Financial News
- 5 THE MOVIE CHANNEL (East)—The first 24 hour, all movie, commercial free channel
- 6 WTBS—24 hours of family directed movies, sports, specials and syndicated programs
- 7 ESPN (Entertainment and Sports Network)—24 hour sports
- 8 CBN (Christian Broadcasting Network)—Family entertainment offering, movies, comedies, westerns, magazine shows, continuing dramas and inspirational shows

SATCOM F3 (continued)

- 9 USA NETWORK—Broad based special interest programming including, sports children's programs, women's programs and nighttime entertainment
- 10 SHOWTIME (West)—24 hour movies, comedies, theater, concerts and late night adult programs
- 11 MTV (Music Television)—The first 24 hour advertiser supported stereo video music channel
- 12 SHOWTIME (East)—Same as channel 10
- 13 HBO (West)—The industry's most popular full service movie, sports and entertainment channel
- 14 CNN (Cable News Network)—Live, 24 hour news coverage, in-depth sports, weather, financial, investigative and feature reporting
- 15 CNN HEADLINE NEWS—Continuously updated 30 minute wheel of hard news with a 6 minute window for cable systems to insert local news. For the person who wants a quick news fix.
- 16 HTN (Family Entertainment)—G/PG movies, musical specials and The Travel Channel
- 16 VIDEO CONCERT HALL—Video music promotion service available for tape replay in other time slots
- 17 LIFETIME—Programming about health, relationships, self-development and other self-help topics
- 18 EWTN (Eternal World Television Network)—Religious programming (Catholic)
- 18 REUTER MONITOR SERVICE (Scrambled)—News and price retrieval for professional traders and investors
- 19 C-SPAN—Daily live coverage of the House of Representatives
- 20 CINEMAX (East)—24 hour commercial free variety movie channel
- 21 THE WEATHER CHANNEL—Live and updated, national and local weather service
- 22 MSN—The Informational Channel—Daytime information channel featuring The Home Shopping Show, Biznet News Today, and other consumer, health, business and travel shows.
- 22 USA BLACKOUT NETWORK—Affiliate programming that can be utilized in place of sports events that are affected by blackout regulations.
- 23 CINEMAX (West)—Same as Cinemax Channel 20
- 24 HBO (East)—Same as HBO Channel 13

SUBCARRIER AUXILIARY SERVICES

- 1 ARTS & ENTERTAINMENT—Stereo entertainment and cultural programs, stereo/audio, 5.58/5.76 MHz
- 2 SATELLITE RADIO NETWORK—Religious programming, mono/audio, 6.2 MHz
- 3 BONNEVILLE EASY LISTENING MUSIC—Popular easy listening music, stereo/audio, 7.38/7.56 MHz
- 3 COUNTRY COAST-TO-COAST—Stereo music service intended for radio stations with modern/country music, stereo/audio 5.94/6.12 MHz
- 3 ELECTRONIC PROGRAM GUIDE—An hour by hour customized, alphanumeric, on-screen program guide, text 7.237 MHz
- 3 MOODY BROADCASTING NETWORK—Religious variety including music, drama and education, stereo/audio, 5.47/7.92 MHz
- 3 SEEBURG/LIFESTYLE MUSIC—Upbeat commercial free music service in monaural intended as a graphics channel enhancer, 7.695 MHz
- 3 STARDUST—Music includes: The Big Bands of the 40's, POP from the 50's and 60's, and selected music from the 70's, Stereo/Audio, 8.055/8.145 MHz
- 3 STARSTATION—Adult Contemporary Music, stereo/audio, 5.58/5.76 MHz
- 3 WFMT-Chicago—Fine arts and classical programming, stereo/audio, 6.3/6.48 MHz
- 5 THE MOVIE CHANNEL—Stereo Broadcast, stereo/audio, 5.8/6.8 MHz
- 6 MUSIC IN THE AIR—Broadway/Hollywood musicals, stereo/audio, 5.58/5.76 MHz
- 6 MUSIC IN THE AIR—Country Music, stereo/audio, 5.40/5.94 MHz
- 6 MUSIC IN THE AIR—Comedy, mono/audio, 6.435 MHz
- 6 MUSIC IN THE AIR—50's and 60's Hits, mono/audio, 6.435 MHz
- 6 MUSIC IN THE AIR—Big Band Hits, mono/audio, 7.785 MHz
- 7 ESPN—Stereo Broadcast, Stereo/Audio, 5.58/5.76 MHz
- 8 CABLE JAZZ NETWORK—Jazz, stereo/audio, 5.94/6.12 MHz
- 8 LOVE SOUNDS—Vocal and instrumental music, stereo/audio, 6.30/6.48 MHz
- 8 NICE & EASY—Contemporary easy listening, stereo/audio, 5.58/5.76 MHz
- 11 MTV—Stereo broadcast
- 14 CNN RADIO NETWORK—Complete updated 30 minute news cycles, mono/audio, 6.3 MHz
- 16 COMMODITY COMMUNICATIONS CORP.—Commodity quote service, mono/audio, 6.2 MHz
- 16 HTN—Stereo Broadcast, 5.8 MHz

V.B.I. AUXILIARY SERVICES (Note: Special equipment is necessary to receive the following services. Please contact each specific service for details.)

- 6 AP NEWS CABLE—News, weather, sports, stocks and business news 24 hours a day, Daily, 24 hours, Text
- 6 DOW JONES CABLE NEWS—Business/financial economic news service with strong consumer orientation, Daily, 24 hours, Text
- 6 QUOTRADER—Commodity service designed for use with Apple computer. Firmware™ provided by Quotrader, Daily, 24 hours, Text
- 6 REUTER NEWS-VIEW—Two-channel alphanumeric service delivering general, financial and sports news, Daily, 24 hours, Text
- 6 KEYFAX NATIONAL TELETEXT MAGAZINE—Features news, sports, business, weather, leisure features of regional interest continuously updated 24 hours per day, Text
- 6 SSS CABLE TEXT—Teletext-vertical interval-UPI, Reuter, AP NewsCable, Consumer News and Dow Jones, Daily, 24 hours, Color Text
- 6 UPI CABLENEWS WIRE—24-hour alphanumeric (English and Spanish) news service, Daily, 24 hours, Text

COMSTAR D4

POLARIZATION: ODD—Vertical / EVEN—Horizontal

CHANNEL PROGRAM/DESCRIPTION

- 5 JPD TELEVISION NETWORK—Family oriented films, specials, sports and music
- 9 ON TV (West) (Scrambled)—Movies, entertainment, specials and sports
- 11 ON TV (East) (Scrambled)—Same as above
- 13 ESPN—Same as ESPN Satcom F3, channel 7
- 18 COUNTRY MUSIC TELEVISION—24 hour country music videos
- 18 THE SILENT NETWORK—Entertainment and Information programs in sign language, open captioning and voice

COMSTAR D4 (continued)
SUBCARRIER AUXILIARY SERVICES

18 COUNTRY MUSIC TELEVISION—Stereo Broadcast, mono/audio, 6.8 MHz, Stereo/Audio 5.58/5.76 MHz

WESTAR 5

POLARIZATION: ODD—Horizontal / EVEN—Vertical

CHANNEL PROGRAM/DESCRIPTION

2 THE UNIVERSITY NETWORK (The Unchannel)—Nonsecular programming with Dr. Gene Scott
3 WOR-TV (New York Channel 9)—New York's Independent Station featuring sports, movies, and TV oldies
5 SELECTV—Feature films, specials and sports
7 CBS CONTRACT CHANNEL—CBS Live/Taped Network Programming
8 SPORTSVUE—Wisconsin Regional sports service
10 THE DISNEY CHANNEL (West)—Family programming
11 WPIX—New York's leading independent station featuring family programs, movies and sports.
12 THE DISNEY CHANNEL (East)—Same as channel 10
14 PRO AM SPORTS SYSTEM—Michigan, Ohio and Indiana regional sports service
15 MADISON SQUARE GARDEN CABLE NETWORK—Live sports events from Madison Square Garden
16 THE MEADOWS RACING NETWORK—Nightly harness racing
17 THE NASHVILLE NETWORK—Country-oriented entertainment
21 FNN (Financial News Network)—Live business and financial news including up to the minute stock and commodity quotes
22 THE BLUEMAX THEATER CHANNEL (Scrambled)— X-rated adult programming
23 ARTS & ENTERTAINMENT—Fine Arts Presentation
24 BET (Black Entertainment Television)—Black feature films, classics, specials and sports
24 NJT (National Jewish Television)—Current affairs, entertainment and religious topics of Jewish interest

SUBCARRIER AUXILIARY SERVICES

10 THE DISNEY CHANNEL (West)—Stereo Broadcast, stereo/audio, 5.8/6.8 MHz
12 THE DISNEY CHANNEL (East)—Stereo Broadcast, stereo/audio, 5.8/6.8 MHz
17 THE NASHVILLE NETWORK—Stereo Broadcast, stereo/audio, 5.58/5.70 MHz
23 ARTS & ENTERTAINMENT—Stereo Broadcast, stereo/audio, 5.58/5.76 MHz

ANIK B

POLARIZATION: ODD—Horizontal / EVEN—Vertical

CHANNEL PROGRAM/DESCRIPTION

7 OCCASIONAL TRANSMISSIONS—Network feeds, sports and news
11 CBC NORTH—CBC Network programming (Pacific time zone feeds)
13 OCCASIONAL TRANSMISSIONS—Network feeds, sports and news
15 CBC (French)—French language CBC programming
17 CBC OCCASIONAL TRANSMISSIONS—CBC Network programming
19 CBC NORTH—CBC Network programming (Atlantic time zone feeds)
21 OCCASIONAL TRANSMISSIONS—Network feeds, sports and news

ANIK D1

POLARIZATION: ODD—Horizontal / EVEN—Vertical

CHANNEL PROGRAM/DESCRIPTION

8 CHCH-TV, Hamilton, Ontario—Ontario's leading independent station
9 WDIV-TV, Detroit—NBC Affiliate feeds
11 CBC NORTH (West)—CBC Network Programming (Pacific Time Zone feeds)
14 TCTV-TV (Telemedic Communications Television)—TVA French network programming from CHLT, Sherbrooke and CFTM, Montreal
15 CBC (French)—French language CBC Eastern Time Zone feed
16 CBC Parliamentary Network (French)—Daily live coverage of the Canadian House of Commons from Ottawa
18 CITV-TV, Edmonton, Alberta—Alberta's leading independent station
20 CBMT-TV, Montreal—CBC English network affiliate
21 WTVS-TV, Detroit—PBS Affiliate feeds
22 BCTV-TV (British Columbia Television)—Vancouver, British Columbia's leading CTV network station
23 WJBK-TV, Detroit—CBS affiliate feeds
24 CBC Parliamentary Network (English)—same as Tr. #16 in English
24 CBC North (French)—CBC Network programming

SUBCARRIER AUXILIARY SERVICES

8 CKO-FM, Toronto, Ontario—All news and information radio, mono/audio, 6.17 MHz
8 CHFI-FM, Toronto, Ontario—Traditional MOR music, mono/audio, 6.8 MHz
14 CITE-FM, Montreal, Quebec—French language traditional MOR music, mono/audio, 6.17 MHz
14 CKAC-AM, Montreal, Quebec—French language MOR/contemporary music, mono/audio, 5.41 MHz
16 CBBK-FM, Kingston, Ontario—CBC English discrete stereo radio, stereo/audio, 5.4/5.58 MHz
16 CBOF-FM, Ottawa, Ontario—CBC French discrete stereo radio, stereo/audio, 5.76/5.94 MHz
18 CIRK-FM (K-97), Edmonton, Alberta—Progressive Rock, stereo/audio, 6.17 MHz
20 CBM-AM, Montreal, Quebec—English Network Affiliate, mono/audio, 6.12 MHz
22 CBC-FM—CBC Programming, mono/audio, 6.17 MHz
22 CFMI-FM, Vancouver—Soft album rock, mono/audio, 7.42 MHz
23 CBOF-FM, Ottawa, Ontario—French discrete stereo radio, stereo/audio, 5.4/5.88 MHz
23 CBBK-FM, Kingston, Ontario—CBC English discrete stereo radio, stereo/audio, 5.76/5.94 MHz

WESTAR 4

POLARIZATION: ODD—Horizontal / EVEN—Vertical

CHANNEL PROGRAM/DESCRIPTION

4 HUGHES TELEVISION NETWORK—Occasional Sporting Events
4 NEW YORK RACING AUTHORITY (NYRA)—Closed circuit horse racing from Belmont Park
5 OCCASIONAL TRANSMISSIONS—Network feeds, sports and news
5 DEMSAT—Democratic Party Satellite Network
6 XEW-TV—Mexico's Leading Network Station

WESTAR 4 (continued)

10	OCCASIONAL TRANSMISSIONS—Network feeds, sports and news
11	CATHOLIC TELECOMMUNICATIONS NETWORK OF AMERICA—Scrambled religious programming
15	PUBLIC BROADCASTING SYSTEM—Schedule A programming
16	CABLE NEWS NETWORK (CNN)—Incoming regional bureau news feed
17	PUBLIC BROADCASTING SYSTEM—Schedule B programming
20	ABC CONTRACT CHANNEL—ABC Live/taped network programming
21	PUBLIC BROADCASTING SYSTEM—Schedule C programming
22	OCCASIONAL TRANSMISSIONS—Network feeds, sports, news
23	PUBLIC BROADCASTING SYSTEM—Schedule D programming

TELSTAR 301**POLARIZATION: ODD—Vertical / EVEN—Horizontal****CHANNEL PROGRAM/DESCRIPTION**

7/8	OCCASIONAL TRANSMISSIONS—Sports, teleconferencing news and network feeds
9	ROBERT WOLD COMMUNICATIONS—Sports, news and network feeds
10	SATELLITE TELEVISION SERVICE (ABC)—ABC live/taped network programming (Central Time Zone feeds)
12	ABC TELEVISION NETWORK—ABC contract channel covering Los Angeles/New York programming and news feeds
13/14	OCCASIONAL TRANSMISSIONS—Sports, news and network feeds
15	ABC INTERNATIONAL TELEVISION NETWORK—ABC London International news feeds
16/21/22/24	OCCASIONAL TRANSMISSIONS—Sports, teleconferencing, news and network feeds

WESTAR 3**POLARIZATION: ALL—Horizontal****CHANNEL PROGRAM/DESCRIPTION**

5	CNN (Cable News Network)—Incoming regional bureau news feed
19	HUGHES TELEVISION NETWORK—Occasional sports events
21	OCCASIONAL TRANSMISSIONS—Network feeds, sports and news
21	INDEPENDENT NETWORK NEWS—National newscasts for independent broadcast stations
23	OCCASIONAL TRANSMISSIONS—Network feeds, sports and news
23	HSC-TV/THE BAMC HOUR—Medical training by Brooke Army Medical Center, Academy of Health Science

AUXILIARY SERVICES

1	AP NEWSCABLE—Automated alphanumeric general news and information service
2	NATIONAL PUBLIC RADIO—Public radio station featuring a variety of programming
2	TEXAS STATE NETWORK—State radio station featuring news, sports and entertainment

COMSTAR D3**POLARIZATION: ODD—Vertical / EVEN—Horizontal****CHANNEL PROGRAM/DESCRIPTION**

1	SATELLITE TELEVISION SERVICE (NBC)—NBC live and taped network programming for Central Time Zone feeds
10	SATELLITE TELEVISION SERVICE (CBS)—CBS live and taped network programming for Central Time Zone feeds
13	SATELLITE TELEVISION SERVICE (ABC)—ABC live and taped network programming for Central Time Zone feeds
17	SATELLITE TELEVISION SERVICE (CBS)—CBS live and taped network programming for Los Angeles/New York feeds

SATCOM F4**POLARIZATION: ODD—Vertical / EVEN—Horizontal****CHANNEL PROGRAM/DESCRIPTION**

2	BRAVO—Cultural programming including dance, jazz, theater, symphony and opera
3	SPN (Satellite Programming Network)—Full variety entertainment
4	HOME SPORTS ENTERTAINMENT (Dallas)—Texas, Louisiana, Arkansas, Oklahoma, and New Mexico regional sports service
6	ESPN—West coast feed of Business Times on ESPN only
7	NCN (National Christian Network)—Religious programming for the entire religious community
9	SPORTS VISION—Regional sports network in the Chicago area
11	HOME SPORTS ENTERTAINMENT (Houston)—Same as channel 4
12	THE PLAYBOY CHANNEL—Adult Entertainment Channel
15	BIZNET The American Business Network—Business and public affairs programming
17	TBN, Trinity Broadcast Network—Religious programming including talk shows, variety shows and Bible studies
18	AMERICAN FORCES RADIO & TELEVISION SERVICE—Independent programming and various network feeds
24	NBC CONTRACT CHANNEL—NBC live/taped network programming

AUXILIARY SERVICES

2	BRAVO—Stereo Broadcast, stereo/audio, 5.8 MHz
3	IN TOUCH—Reading service for the blind and handicapped, mono/audio
3	GEORGIA RADIO NEWS SERVICE—News, sports and information features, mono/audio, 7.695 MHz
3	NATIONALITY BROADCASTING NETWORK—Alternating multi-language presentation of music, news, sports and cultural programming, mono/audio, 6.435 MHz
3	RHYTHM AND BLUES—Featuring album cuts from various artists, stereo/audio, 5.4/6.3 MHz
3	THE ROCK CHANNEL—Upbeat music, stereo/audio, 7.38/7.56 MHz
3	SPN—Stereo Broadcast, stereo/audio, 5.58/5.76 MHz
7	FAMILY RADIO NETWORK (East)—Bible centered religious program with music and talk programs, stereo/audio, 5.58/5.76 MHz
7	FAMILY RADIO NETWORK (West)—Same as above, 5.94, 6.12 MHz
7	SHERIDAN BROADCASTING NETWORK—News, sports, jazz and rhythm and blues, 7.38/7.56 MHz
17	SATELLITE JAZZ NETWORK—New and traditional jazz music, stereo/audio, 5.58/5.76 MHz

WESTAR 2**POLARIZATION: ALL—Horizontal****CHANNEL PROGRAM/DESCRIPTION**

3	OCCASIONAL TRANSMISSIONS—Sports, news and network feeds
11	OCCASIONAL TRANSMISSIONS—Sports, news and network feeds
19	OCCASIONAL TRANSMISSIONS—Sports, news and network feeds

SECRET CB INDEX - VOLUMES 1 THRU 19

CODES: A - ALIGNMENT PROCEDURE; C - CONVERSION; FC - FREQUENCY CHART; M - MISCELLANEOUS

INFORMATION; S - SLIDE; SC - SCHEMATIC; T - TUNE UP.

	<u>VOL/PG</u>		<u>VOL/PG</u>		<u>VOL/PG</u>		<u>VOL/PG</u>
<u>MISCELLANEOUS:</u>		<u>BRISTOL</u>		<u>COBRA (cont.)</u>		<u>COURIER (cont.)</u>	
Conversion tips for		BCB-2271.....	T-16/41	142GTL.....	C-4/50,10/28-29	REDBALL.....	T-1/21
all SSB Radios.....	9/7			142GTL.....	S-4/50,6/64	RENEGADE 40.....	T-3/46
"A" Channel Mod. for		<u>BROWNING</u>		142GTL.....	S-8/35-37,10/28	ROUGE 40.....	T-3/43
all SSB Radios.....	9/16-17	BARON.....	S-15/15-17;M-19/52	142GTL.....	T-4/50	SPARTAN.....	C-5/30,53,55,57
Cybernet Freq. Mod.....	8/18	MARK III.....	C-6/28	146GTL..C-11/17-18,15/18-19		C-1/61-62;S-1/61,5/55
Uniden MB8719 Mod.....	8/15	MARK IV.....	C-6/29-30	146GTL.....	S-10/41,11/17	TRAVELLER II.....	T-18/65
MB8719 Mod.....	10/25-26,18/68	MARK IVA.....	C-14/5-6	146GTL.....	T-10/41		
MB8719 w/11.1125 Mod..	11/15	MARKIV & IVA.....	C-7/8-14	148GTL.....	C-8/16,18/29		
Update.....	14/11-12	SABRE.C-1/27;T-14/42;M19/52		148GTL.....	S-8/16;T-6/19	<u>COYOTE</u>	
PLL 01A Mod.....	9/15-17			148GTL-B...C-17/40-43,19/60		23.....	T-16/32
PLL 02A Mod.....	3/13-15	<u>CHANNEL MASTER</u>		148GTL-B...SC-17/43;T-16/55			
PLL 02A Mod.....	4/54-55,18/56	CB6830.....	C-14/41;T-16/55	148GTL-DX.....	C-15/20-24	<u>CPI</u>	
02A Truth Table.....	15/12-13	CB6834.....	T-14/44	C-16/50-51;17/47,54-58	300.....	C-8/21
23 ch. 02A AM conv.....	12/32	CB6835.....	T-6/18	C-18/13,17,23,26;19/37,46	400.....	C-8/21;T-10/59
Tech Tips on the 858				148GTL-DX.....	SC-19/27-28	2000.....	C-3/25
Chassis.10/55,19/59,60,67		<u>CHRYSLER</u>		148GTL-DX.....	T-16/43-49	2000 Low.....	C-9/23
Uniden 858 Update....	9/8-11	4048076/8077.....	T-6/18	148GTL-DX.....	M-19/68	2500.....	C-5/37-38;S-5/37
How to get on 28 & 29 MHz				150GTL.....	T-17/42;M-19/31		
w/upD858 PLL.....	11/4-7	<u>CLARION</u>		1000GTL.....	T-6/18,14/42	<u>CRAIG</u>	
uPD858 AM Conv.....	11/35	DMA066.....	T-3/45	2000 (C.A.P.).....	C-6/23	L101.....	T-6/20,11/42
Receiver Widebanding for		JC202E.....	T-3/45	2000GTL.....	C-5/20,7/15-17	L102.....	T-6/20
858 Chassis.....	13/34	RCJ003.....	T-3/45	2000GTL..	C-15/25-28,18/29	L131.....	C&S-9/12-14;T-10/59
Thumbwheel conv. for		TC203E.....	T-6/18	2000GTL.....	S-12/20,13/40	L132.....	C-9/12,10/47,11/10
858 Chassis.....	13/35-37			<u>COLT</u>		S&T-9/12,10/47
How to increase ANL		<u>COBRA</u>		SX33.....	C-3/4-7	L231.....	C-9/12-14,T-10/60
efficiency 70%.....	11/8	CAM89.....	C-14/45-46;T-14/45	222.....	T-6/20	S-9/12-14,12/3
Ham Radio Crystal		19.....	T-7/51	290.....	C-3/4-7;T-3/4	L232..C&S-9/12,10/47,11/10	
Selector.....	12/24	19GTL.....	T-12/34	320FM.....	A-19/48-51	T-10/47,11/10
SM5104 AM Chassis..	18/20-21	19XS.....	T-18/51	350.....	T-14/46	L321.....	C&S-14/12
SM5104 SSB..	6/26-27,9/20-22	21GTL.....	T-3/41,58	355.....	T-18/19	4102.....	T-16/32
For most 23 ch. radios		21XLR.....	T-1/20,10/58	390.....	C-3/4-7;T-3/4		
see crystal cross ref.		25GTL.....	T-3/41,58	480.....	C-3/8-15,5/39	<u>DAK</u>	
guide.....	1/6-18,2/5-13	25LTD.....	T-17/35	480.....	S-3/11;T-3/8,58	MARK II.....	T-10/60
Phase Lock Loop Xtal		29GTL.....	T-3/45,14/42	510.....	A-18/44-45;SC-17/45	MARK V.....	T-12/34
Cross Ref. Guide....	6/1-2	29LTD.....	T-13/59	510.....	T-17/42,45	MARK IX...C-5/21-23,9/18-19	
		29XLR.....	T-1/20	485.....	C-3/8-15;S-3/11,4/49	MARK X...C-4/39-46;S&T-4/45	
<u>AIR COMMAND</u>		32XLR..C-4/47;T-3/58;M-19/52		485.....	T-3/8,6/19	<u>DEMCO</u>	
CB-640.....	T-5/38	45XLR.....	C-18/67;T-12/34	800.....	C-3/4-7;T-3/4,10/58	STAR II.....	C-5/60
		46XLR.....	T-3/43	1000.....	C-3/8-15;S-3/11	SUPER SATELLITE.....	C-5/60
<u>ALARON</u>		47XLR.....	T-3/45	1000.....	T-3/8,58		
B-4075.....	T-9/30	50XLR..C-16/53,18/22;T-3/43		1200.....	T-9/30-31,16/55	<u>EVERSONIC</u>	
B-4900.....	T-9/30	55XLR..C-16/53,18/22;T-3/43		<u>COMMANDO</u>		DK-222.....	T-19/42
B-5050A.....	T-9/30	66GTL.....	T-10/58	2340.....	T-1/21		
B-5200.....	T-3/41	77X.....	T-9/30	<u>COMMTRON</u>		<u>FANON</u>	
<u>AMERICAN MOTORS</u>		78X.....	T-4/49,6/19,8/44	XII.....	A-18/44-45;SC-17/45	10-40.....	T-6/20
3221847/48/49/50....	T-12/34	85.....	T-15/61	<u>CONVOY</u>		FANFARE 125F.....	T-3/45
		86.....	M-19/52	CON-400.....	T-3/58	FANFARE 182F.....	T-3/41
<u>AUDIOVOX</u>		86XLR.....	T-3/45	<u>COURIER</u>		FANFARE 184DF.....	T-3/47
MCB750.....	T-3/41	87GTL.....	T-6/19	BLAZER 40D.....	T-3/58	FANFARE 185PLL.....	T-3/46
MCB5000.....	T-11/42	87XLR.....	M-19/52	CARAVELLE.....	T-18/65	FANFARE 190DF..	T-3/47,7/51
MCU6000.....	T-6/18,15/60	89GTL.....	T-6/18	CENTURION.....	S-1/61,5/55	FANFARE 350F..	C-5/57;S-5/55
		132-A.....	S-1/28	CENTURION PLL..	C-1/31,61-62	T-3/47,13/12
<u>AUTOMATIC</u>		132-B.....	C-1/53	C-5/57		
CBH2265.....	T-3/41	132XLR..C-4/47;T-3/45,16/39		CENTURION 40D.....	C-10/53	<u>GEMTRONICS</u>	
		C-19/52;S-10/45-46,15/15-17		S-10/53;T-10/53,13/10	GTX-23.....	T-15/61
<u>BETA</u>		135-A.....	S-1/28	CHIEF 23.....	T-18/65	GT44.....	T-2/42
23 Deluxe.....	T-16/32	135-B.....	C-1/53;S-1/29	CLASSIC II.....	T-18/65	GT55.....	T-3/48
		135XLR.....	C-4/38,10/43-46	CLASSIC III.....	T-18/65	GTX66.....	T-6/21
<u>BOWMAN</u>		135XLR...C-18/40-41;S-4/38		CLASSIC PLL40..	T-3/43,10/59	GTX77...C-5/39;S-4/49;T6/21	
CB555.....	T-3/44	135XLR.....	S-8/38,10/45-46	COMET 23.....	T-18/65	GTX2325.....	C-15/29
CB750.....	T-2/43	135XLR...S-15/15-17;M-19/52		CONQUEROR.....	T-18/65	GTX3323.....	T-17/59
CB755.....	T-14/44	135XLR...T-3/45,4/38,16/39		GALAXY...C-5/53-54,7/18-22		GTX4040.....	T-3/48
CBH900.....	T-3/44	138.....	S-1/28	S-5/53,7/19;T-5/53	GTX5000.....	T-3/42,13/60
CB910.....	C-11/41,13/58	138XLR...C-1/20-23		GLADIATOR PLL..	C-1/31,61-62		
CB910.....	T-1/21,3/44	138XLR.....	S-1/23;T-1/20	S-1/61,5/55	<u>FIELDMASTER</u>	
CB920..C-14/43;T-1/21,14/43		139.....	S-1/30;T-1/20	NIGHTRIDER 40D.....	T-3/46	MICRO MINI 40.....	C-11/37
CB930...C-3/21;T-1/21,3/44		139XLR.....	C-1/20-23	RANGLER 40D.....	T-3/58	TR-40.....	C-15/63
CB950..C-5/39;S-4/49;T-3/43		139XLR.....	S-1/23;T-1/20	REBEL 23+.....	T-18/58		
CBH990.....	T-5/43	140GTL.....	C-3/19-20,4/50			<u>GENERAL ELECTRIC</u>	
CBR9600.....	T-2/42,3/41	140GTL.....	C-10/28-29			3-5800A.....	T-3/50
CBR9940.....	T-3/44	140GTL...S-4/50,6/64,10/28				3-5801A.....	C-16/33,17/39
CBR9950.....	T-10/58	140GTL.....	T-3/20,58;4/50			3-5804B.....	T-6/21
						3-5804F.....	T-10/61

CODES: A - ALIGNMENT PROCEDURE; C - CONVERSION; FC - FREQUENCY CHART; M - MISCELLANEOUS
INFORMATION; S - SLIDE; SC - SCHEMATIC; T - TUNE UP.

VOL/PG
GENERAL ELECTRIC (cont.)
 3-5804G.....T-12/35
 3-5805A.....T-9/31,10/61
 3-5806.....T-18/65,19/64
 SC-19/65
 3-5811B.....T-9/31,10/61
 3-5812A.....T-10/61
 3-5813A.....C-14/41
 3-5813B.....T-18/34
 3-5814B.....T- 6/21
 3-5817A.....T- 7/51
 3-5818A.....T- 2/42
 3-5819A.....T-11/42
 3-5821A.....T- 9/31
 3-5821B.....T- 3/54
 3-5825A.....T-9/31-32
 3-5830.....T- 3/42
 3-5869A.....C-14/41;T-2/42
 3-5871A.....T-13/60
 3-5871B.....T- 3/46
 3-5875A.....C&S-10/48
 T-9/32,10/48
 3-5900A.....T-12/35

GENERAL MOTORS
 CBD-20U.....T-12/36
 CBD-203.....T-3/48
 DELCO AM/FM/CB...C-11/38-40
 70BFMC3.....T-2/43
 80BCB2.....T-6/20
 90BCB1.....T-10/60
 90BFMC1.....C&T-12/26
 90BFPC1.....C&T-12/26
 90BFTC1.AM/FM/CB...T-10/60
 91YFMC1.....C&T-12/26
 4120.....T-3/46
 4145.....T-9/32
 4175.....T-3/46

GREAT
 K605.....T-16/32
 GT818.....T-16/32
 GT838.....T-18/65

HALLICRAFTER
 HCM271.....C-5/50-51,6/39

HAM INTERNATIONAL
 CONCORDE II.....A-19/48-51

HYGAIN
 I-A.....C-1/22
 PLL.....C-1/32
 II.....C-8/20
 IV 673.....T-18/34
 HY-RANGE V.....T-18/51
 V.....S-11/11
 V-EXPORT.....A-19/48-51
 VII.....T-3/59
 623.....S-1/33
 674A.....S-4/60;T-4/60
 V-674B.....T-1/21
 2701.....T-2/42
 2702.....T-3/48
 2703.....T-3/48
 2716.....T-12/36

ITT
 CB-4000M.....C-13/61;T-13/61
 CB-4400M.....C-4/17-18;T-4/17

JC PENNEY
 PINTO SSB.....S-1/44
 6241.....T-18/51

VOL/PG
JC PENNEY (cont.)
 6246.....C & T- 13/61
 6247.....S-13/13
 6248.....C-8/24;S&T-13/14-15
 981-6203.....T-15/30
 981-6204.....T-9/32
 981-6225.....T-14/47
 981-6235.....T-19-42
 981-7461.....T-9/32
 981-8360.....T-10/61,18/51

JIL
 615CB.....T-11/42

JOHNSON-MESSENGER
 40.....T-12/36
 50.....T-7/51
 80.....T-7/51
 123A.....T-1/21
 132.....T-19/42
 352-VIKING.....S-1/34
 4120.....T-3/47
 4125.....C & T-13/61
 4135.....T-3/48
 4140.....C-15/31;T-3/54
 4145.....T-3/54
 4170.....T-3/47,11/43
 4174.....C & T-13/61
 4175.....T-3/47,11/43
 4250.....T-3/48
 4730.....C & S-10/49-51
 VIKING 200.....T-12/36
 VIKING 260/270.....T-3/49
 VIKING 4330/4360...T-11/43
 VIKING 4740.....C&S&T-11/12

KENWOOD
 TS-120S.....C-12/22
 TS-130.....C-12/23
 TS-430S.....C-18/24-25
 TS-820S...C-14/7-8,15/32-34

K-40
 K-40AM.....T-15/60

KRACO
 KB2345.....T-18/34
 KB4045.....T-14/47
 KCB1401.....T-18/57,19/42
 KCB2330A.....C-9/15
 KCB2340.....T-2/42
 KCB4000.....T-11/43
 KCB4003.....T-3/42
 KCB4005.....T-9/38,11/43
 KCB4020.....T-3/49
 KCB4030.....T-8/44
 KCB4080.....T-3/50
 KCB4090.....C-19/52
 KCB4095.....C-19/52
 KCB4806.....C-15/59
 KCB4088.....T-3/50

KRIS
 XL25.....T-2/43

LAFAYETTE
 COMSTAT.....T-11/45
 DYNA-COM 40.....T-11/44
 CHB740.....T-15/60,16/55
 HB640.....T-2/43
 LM-100.....T-12/36
 LM-300.....T-12/37
 MICRO-723.....T-19/42
 SSB75.....C&S&T-14/9
 SSB140.....T-11/44

VOL/PG
LAFAYETTE (cont.)
 TELESTAT 1240.....T-5/14
 2400 FM.....M-19/59

LAKE
 400.....C-16/52,19/33
 410.....T-12/37
 450.....T-12/37
 600.....T-12/37

MAJOR
 M120....SC&T&FC-19/23,29,43

MARCO
 CB-444..SC&T&FC-19/21,30,43

MECTRON
 ME400.....C-17/34
 ME502.....C-14/41

MEDALION
 63-240.....T-3/50

MIDLAND
 CAP 858.....C-5/30
 100M.....T-10/67
 102M.....T-14/42,17/59
 103M.....T-17/65
 150M.....T-7/52
 13-857.....C-11/36
 13-858.....T-14/42
 13-862.....C&T-14/48-49
 13-867.....T-13/62,19/42
 13-879.....T-14/50
 13-881.....T-15/61
 13-882C.....C-13/62,15/35
 T-13/62
 13-883B.....C&S-12/4
 13-892.....S-4/48,11/13
 T-4/48
 13-893.....S&T-4/51
 13-898.....S-1/36
 13-898B.....S-1/35
 63-445.....T-11/45
 76-858...C-16/21-24;T-3/49
 76-860.....T-14/51
 76-863.....T-3/50,9/33
 77-101B.....T-8/44
 77-101C.....T-12/38
 77-808.....T-18/51
 77-821.....T-3/42
 77-824.....T-8/44
 77-824B.....T-12/38
 77-824C.....T-12/39
 77-838.....T-9/33
 77-849.....T-3/50
 77-853.....T-16/55
 77-856.....T-11/45
 77-861.....C-12/26;T-3/50
 77-861B.....T-11/45
 77-865.....T-9/33
 77-899.....T-9/33
 77-963.....T-3/42
 78-574.....C&S-14/10
 T-9/38,12/39,14/10
 78-999.....S&T-12/5
 79-891.....S-12/6;T-12/5
 79-892.....C-15/36-38
 S-11/14;T-3/49
 79-893.....C&T-2/20
 79-900.....C-5/47,18/62
 S-5/47;T-9/33-34
 1001.....T-17/65
 2001(Export)..SC&T-19/26&29

VOL/PG
MIDLAND (cont.)
 3001.....T-12/37
 4001.....T-7/52
 5001.....T-12/37
 6001.....C-11/61,16/60-62
 S&T-11/16
 7001..C-8/21,11/16,16/60-62
 S-8/21,11/16;T-11/16
 7001(79-007).....T-11/45-46

MOPAR
 4094173.....T-3/51
 4094176.....T-3/51
 4094177.....T-3/49
 4094178.....T-3/60

MORSE
 2001.....T-14/42
 3005.....C-2/27

MOTOROLA
 CB555.....C&S&T-12/7
 CC975AX.....T-16/40
 CF925AX.....T-11/46
 CM540.....T-18/27
 MOCAT 40.....T-11/46
 T4000A/05A/10A/20A...T-3/50
 T4025A.....C-10/46

NESCO
 1249.....C-6/38

N. D. I.
 PC-102.....T-11/46
 PC-200.....T-7/52
 PC-201.....S&T-12/8

OMNIVOX
 CB-1000.....T-18/66

PACE
 CBL44.....T-14/42
 CBL66.C-15/42;T-15/60,19/42
 1000.....S-1/37-38
 1000MC/1000BC...C-15/39-41
 DX1023B.....S-1/39
 2300C.....C-19/33
 8003.....T-11/47
 8008.....T-2/43
 8010A.....C-15/43,17/60-61
 8015A.....C-15/43,17/60-61
 8016.....T-11/47
 8025.....C-15/44;T-19/42
 8041.....T-19/33
 8046.....T-9/33
 8092.....C-6/35-36;S-6/37
 8093.....C-15/48
 8113.....T-12/39
 8117.....T-11/47
 8155.....C-15/43,19/33
 T-9/34,12/40
 8193.....S-12/9;T-7/52

PACIFIC
 800 SSB...C-18/16,19/57-58
 S-18/15;T-16/55,19/29
 SC-19/25

PALOMAR
 49.....T-3/60
 500..C-4/19-20,5/32-36,8/21
 500.....S&T-4/19,5/32,35
 500B.....T-18/67
 2400 (Export) next column

CODES: A - ALIGNMENT PROCEDURE; C - CONVERSION; FC - FREQUENCY CHART; M - MISCELLANEOUS
INFORMATION; S - SLIDE; SC - SCHEMATIC; T - TUNE UP.

VOL/PG	VOL/PG	VOL/PG	VOL/PG	
<u>PALOMAR (cont.)</u> 2400 (Export)...A-18/30-33SC-17/44;T-17/42,44 4100.....T-3/54	<u>RAIDER</u> 4060.....C-15/46	<u>ROBYN</u> 007-140.....T-3/52 AM500D.....T-3/52 DG130D.....T-3/56 GT-410D.....T-3/57 GT-440D.....C-1/23 LB120.....T-3/52 SB-505.....C&S&T-5/41-42 SB-520D.....C&T-2/21-22 SB-540D...C-5/19,36,7/25-28S-5/19 SX-401.....T-3/57 SX-402D.....T-3/57 T240D.....S&T-13/63T-3/56,13/60 WV-23.....C-1/24-25 WV-110.C-12/31;T-3/56,11/50	<u>SBE (cont.)</u> TOUCH/COM.....C-1/50-51 TOUCH/COM 40.....T-9/36 TRINIDAD III.....T-3/61	<u>SEARS</u> 23 Ch. SSB.....S-1/44 CM-6000LA.....T-3/59 CM-6000LC.....T-3/59 D63911 (861C).....C-10/26 ROADTALKER (SM5104).S-12/18 370-38050700.....T-3/54 562-38200700.....T-3/55 562-38220700.....C-10/56 663-38020800.....T-7/53 663-38070700.....T-3/61 663-3810.....C&S&T-11/22 663-381050.....T-11/21 934-36740500.....T-18/57 934-3677150..C&S&T-12/16-17 934-36772600.C&S&T-12/16-17 934-38060700.....T-17/65 934-38061700.....T-11/50 934-38062700.....T-10/65 934-38080700.....T-9/37 934-38081700.....T-9/38 934-38120700.....T-3/61 934-38260700.....C-6/26-27C-11/23;S-10/52;T-7/53 934-38270700.....C-5/28-29C-9/20-22;S-5/28,9/20T-7/54 934-38310700...S-5/19,9/22T-7/54-55
<u>PANASONIC</u> CR-B474EU(AM/FM/CB)..T-9/34 RJ3150.....C-18/18 RJ3200.....T-14/42 RJ3250.....T-11/47 RJ3600.....C-10/57;T-11/48 RJ3660.....T-14/52 RJ3700.....C&S&T-13/16-17	<u>RCA</u> 14T270.....T-9/36 14T300.....T-2/43 14T302.....C-4/36,5/11,39S-4/49;T-3/53 14T303.....T-11/48	<u>ROYCE</u> 580.....T-16/32 582.....T-12/42 604.....T-3/56-57 607.....T-12/42 611.....T-14/55 1-600.....T-19/64 1-601.....C-1/26 1-612.....C-5/45-46 1-617.....T-3/52 1-619.....T-3/56 1-621.....T-3/57 1-625.....T-3/56 1-632.....C&S&T-11/21C&S-13/23;S-5/14 1-639.....C-15/48;T-12/41 1-641.....C&S&T-11/20S&T-4/51;T-3/60 1-642..C&S&T-13/24;T-18/51 1-650.....T-14/42 1-651.....T-7/55 1-655.....C-15/47;T-11/50 1-660.....T-2/42 1-673.....T-3/52 1-675.....T-3/53 1-680.....T-3/52	<u>SHAKESPEARE</u> GES240.....T-3/53	
<u>PEARCE-SIMPSON</u> BENGAL.....S-1/40 CHEETA ...C-1/31-32;S-1/40 COUGAR 23.....T-14/53 JAGUAR 40B.....T-19/42 LEOPARD B.....T-3/49 PUMA 23B.....T-13/62 SIMBA.....C-1/31-32;S-1/40 SUPERTIGER 40A.....T-3/60 TIGER 40A.....T-9/34	<u>REALISTIC/TRC</u> 45A.....T-4/37 47.....S-1/41;T-1/21 48.....S-1/42 57.....C&S&T-12/28;T-1/21 83.....T-19/42 99A.....T-4/37 100.....T-4/37 180.....T-4/37 200.....T-4/37,10/63 204.....T-10/63 205.....T-12/40 206.....T-14/55,19/42 209.....T-10/63,12/49 210.....T-16/32;M-19/47 211.....T-17/34 212.....T-17/34 410.....T-12/29 411.....T-15/60 412.....T-19/42 414.....T-19/42 420.....T-12/41 421.....T-8/44,12/41 421A.....T-9/35 422.....T-8/45 422A.....T-10/64,67 424.....T-3/57,9/35 425.....T-7/53,10/67 426.....T-10/64 427.....T-8/45 428.....T-11/48 431.....C-7/23-24;T-4/37 432.....T-11/48 440.....T-8/45,9/35 441.....T-10/67,11/49 448.....C-11/19,16/25-30S-11/19,17/54T-3/51,10/64,11/19 449.....T-3/51,9/35-36 450.....C&S-10/31 451..C&S&T-12/10-13;T-18/26 452.....T-1/21,3/52 454.....T-8/45 455.....C-12/30;T-3/60 456.....T-10/67 457..C&S&T-10/36;T-9/35-36 458.....S-8/39-40;T-9/35 459.....C&S&T-10/32-35 461.....T-3/51 462.....T-9/36 466.....T-3/51 468.....T-3/57 470.....T-9/39,12/41,16/40 471.....T-8/45 480..C&S&T-10/37-38;T-7/53 490..C&S&T-12/14-15;T-11/49	<u>SANKYO</u> SCS-555.....C&S-11/40	<u>SHARP</u> CB-23.....T-13/63 CB-750A.....C-19/52 CB-800.....T-2/42 CB-2170.....T-12/43 CB-2460.....T-18/57 CB-4370.....T-12/43 CB4470.....T-12/44 CB-4670.....T-7/55 CB-5470.....C&S&T-11/24	
<u>PIONEER</u> GT-100G AM/FM/CB....T-10/62	<u>REGENCY</u> CR240.....T-16/32	<u>SBE</u> LCB-8.....T-12/43 LCBS-4.....C&S&T-7/29-33 LCM-5.....T-9/36 LCM-8.....T-9/36,12/42 LCMS-4.....C&S&T-7/34-37 LCMS-8.....T-12/43 CONSOLE II..C-15/49;S-1/48 CONSOLE IV.....C-2/28-35S-2/34,38-40 CONSOLE V.....C-2/28-35S-2/34,38-40;T-15/61 CONSOLE VI.....C-8/14 CORTEZ.....C&T-14/56-57 CORTZ 40.....T-3/61 FORMULA D.....C-1/49 FORMULA D 40.....T-3/61 MALIBU 40.....T-3/53 SIDEBANDER II...C-2/28-35S-1/47 SIDEBANDER IV.S-2/34,38-40 SIDEBANDER V....C-2/36-37S-2/34,38-40 SIDEBANDER VI.....C-8/14 STOWAWAY.....T-3/53 TAHOE 40.....T-3/53	<u>SILTRONIX</u> SSB.....S-1/45 1011C.....C-1/46 1011D.....C-1/46	
<u>PRESIDENT/UNIDEN</u> ADAMS...C&S&T-2/16,13/18-20 ANDREW J.....T-9/34 DWIGHT D.....S-15/62T-10/62,14/54 GRANT (old)C&S&T-1/22-23,59C&S-2/17,23-26 GRANT (new)...C&S&T-5/24-27C&S-13/21-22;S-8/34 Home Ch. Conv...14/13-17 GRANT-DX.....C&S-19/34-36SC-19/24;T&M-19/29,68 JACKSON DX.....T-19/30FC&SC-19/8-9 JAMES K.....T-7/52 JAMES K (new).....T-12/40 HONEST ABE.....C-1/60 JOHN Q.....C-1/60 MADISON (new)....C&S-10/30 McKINLEY.....C&S&T-4/12-13S-6/64 McKINLEY (new)...C&S-10/29 OLD HICKORY.....T-9/34 TEDDY R.....C-1/60 WASHINGTON.C&S&T-1/22-23,59 WASHINGTON (new).C-10/28-29S-6/64,8/33-34,10/28 ZACHARY T...C-1/60;T-14/54 AR 7.....T-12/40 AR 44.....T-10/63 AR 144.C-11/17-18;S&T-10/41 AR 711.....T-12/34 AX 7.....T-12/45 AX 11.....T-12/45 AX 14.....T-12/45 AX 44.....T-12/45 AX 52.....T-12/45 AX 55.....T-12/45 AX 144.....T-12/45 AX 711.....T-12/40,45 PC 3.....M-19/68 PC 33.....T&M&SC-19/40-41	<u>ROADRUNNER</u> CB5000A.....T-16/41	<u>SOMMERKAMP</u> TS-788DX.....C-13/25-30	<u>SILTRONIX</u> SSB.....S-1/45 1011C.....C-1/46 1011D.....C-1/46	
<u>RAY JEFFERSON</u> CB-845.....C-12/27T-11/48	<u>ROBERTS</u> 40 Ch.....T-14/42	<u>SONAR</u> FS-2340.....C&T-5/31	<u>SPARKOMATIC</u> CB4020S.....C-14/41 SR-42/CBM.....T-3/54	
		<u>STONER</u> PRO-40.....C&S-4/52-53	<u>STANDARD HORIZON</u> 29.....T-1/22 29A.....C-5/59;C&T-13/63	
		<u>SUPERSCOPE AIRCOMMAND</u> CB-340.....C-8/19,9/24 CB-1040.....T-14/57		

CODES: A - ALIGNMENT PROCEDURE; C - CONVERSION; FC - FREQUENCY CHART; M - MISCELLANEOUS

INFORMATION: S - SLIDE; SC - SCHEMATIC; T - TUNE UP.

OOPS! WE GOOFED! AND CORRECTION INDEX!

VOL/PG		VOL/PG		OOPS! WE GOOFED! AND CORRECTION INDEX!			
				ORIGINAL		CORRECTION	
				VOLUME	PAGE #	IN VOLUME	PAGE #
<u>SUPERSTAR</u>		<u>TRS CHALLENGER</u>		✓1	23	5	18
95.....C-19/45;SC-19/19		432.....T-4/23		✓1	61	16	72
.....T-19/30		460.....T-4/27-28,14/59		✓2	20,21	5	18
360.....SC-18/4		600.....T-4/27,29;9/37		✓3	4,7,11,25	5	18
2000.....C-18/28		730.....T-4/27,30		3	25	11	78
		850.....C&S&T-4/21-27,32-35		✓3	33	5	18
	S-16/55;T-7/55		✓3	33	10	71
<u>SURVEYOR</u>		<u>TRUETONE</u>		✓4	5	5	17
620.....T-3/55		CYJ4832-A-87.....T-2/43		4	38	12	66
2610.....T-3/54		CYJ4837-A-87.S-11/14;T-3/59		4	39	13	66
		CYJ4862-A-87.....T-9/39		✓4	45,50	5	17
		MCC4434-A-57.....T-14/60		✓4	51	9	44
		MCC4726-A-67.....T-15/61		✓4	54	17	70
<u>SWAN SIGNET</u>		<u>UNIMETRICS</u>		✓5	19,20	6	25
270.....C-5/58		DOLPHONE.....T-18/65		✓5	24,28	10	72
				✓5	28	6	25
<u>TEABERRY</u>		<u>UTAC</u>		✓5	32	8	41
52 Ch. Capability....C-1/43		TRX-400.....T-3/59		✓5	47	18	62
CAP Mod.....C-5/30		TRX-500.....T-5/56		✓5	48	10	72
BIG T.....T-15/61				6	3,12	13	66
MODEL T.....C-4/3-4;T-3/55		<u>VECTOR</u>		✓6	31,32	7	62,63
.....M-19/68		X.....T-2/43		6	32	11	78
RACER T.....C-1/58;T-3/55		770.....C-4/56-57;T-9/37		✓7		18	79
RANGER T....C-4/1-2,6/24-25		790.....C-4/58-59;T-9/37		✓7		8	42
T BEAR.....C-4/14-15				✓7		37	8
T CHARLIE.....T-10/65		<u>WARDS</u>		7	43	11	78
T COMMAND.....T-3/55		GEN-680A.....T-14/61		✓7	46	19	42
T DISPATCH.C-4/14-15;T-3/55		GEN-696A.....T-14/61		7	49	10	25
TITAN T....C-4/14-15;T-15/61		GEN-719A.....C&S&T-11/10		7	53,63	11	78
STALKER I.C1/57,4/5-6,10/11		GEN-775A.....T-3/61		7	54	13	66
STALKER II.....T-1/21				8	16,17	10	72,73
STALKER III.....T-7/55		<u>WKS</u>		8	17	9	29
STALKER IV.....T-12/44		100.....T&SC&M-19/64,66,67		8	52	11	78
STALKER V.....T-7/55				9	9	10	74
STALKER VIII.....T-10/65		<u>XTAL</u>		9	12	18	79
STALKER IX.C-4/7-9,15/55-57		XSSB10.....T-1/22		9	13	19	79
.....S-4/7-8;T-10/65				9	29	10	72
STALKER IX (EXPORT)....		<u>YAESU</u>		9	51	10	75
.....C-15/50-54;SC-19/20		101.....C-5/58		10	2	11	78
STALKER XII.....T-7/56		FT-7B.....C-7/38-41		10	10,16,28	12	66
STALKER XV..C&S-4/7-9,10/39		FT-102.....C-18/25		10	25	13	66
.....T-10/39		FT-707.....C-10/20-24		10	48	13	67
STALKER XX.....C&S&T-10/40		FT-757GX.....C-18/16		10	49	18	79
STALKER 101/202.....S-4/10		FT-757GX/SX.....C-19/52		11	3,10,15,16,71	12	66
		FT-901.....C-6/3-12		11	4,6,11,41,75	13	67
				11	10	19	68
<u>TENNA</u>		*****		12	7	15	69
10901.....C-15/63;T-10/58				12	27,28	16	72
10902.....T-10/65				13	63	15	69
11302 (AM,FM,CB).....T-9/37				14	12	15	69
				14	22,41	16	72
				15	58	17	70
<u>TRAM</u>				15	63,65	16	72
D12.....C-10/56;T-3/54				16	50,72	17	70
D42.....C-4/47,5/40,19/52				18	23	19	54
D60.....C&S-1/52-53				18	26	19	68
D62.....S-10/45-46,15/15-17							
.....C-19/52							
D64.....C&S&T-13/31							
D80.....C-10/30							
D201....C-1/56,3/22-23,4/48							
.....C-17/53							
D201A.....C-10/54,17/53							
D300.....C-8/11-13;S-12/19							
XL-5.....T-16/32							
XLR(23-SSB).....C-17/53							
<u>TRISTAR</u>							
727.....SC-19/22;T-19/30							
747.....C-15/58,16/68							
.....S-17/35;A-19/48-51							

MISCELLANEOUS INDEX LISTED BY VOLUME

VOLUME 1

	PAGE #
GOLDEN EAGLE MARK IV PING MODIFICATION.....	20
CRYSTAL CROSS REFERENCE GUIDE.....	5-10
LETTER CHART FOR CRYSTAL FREQ. CORRELATION.....	11-18
GENERAL INFORMATION.....	63-67
LINEARS.....	68-70

VOLUME 2

	PAGE #
NEW CRYSTAL CROSS REFERENCE GUIDE.....	5-9
LETTER CHART FOR CRYSTAL FREQ. CORRELATION.....	10-13
PRESIDENT GRANT RF GAIN & ADJACENT CH. REJ. MOD.....	18-19
ROBYN 510D/520D NOISE BLANKER ALIGNMENT.....	25-26
COBRA 139XLR SERVICE BULLETIN ON CRYSTAL DRIFT PROBLEM & PCB CRACKING.....	45-50
SERVICE BULLETIN ON SIDEBANDER II & CONSOLE II FOR IMPROVING CROSS MODULATION REJECTION.....	51
SERVICE BULLETIN-COBRA 29 ON MODULATION IMPROVEMENT, ALSO NOISE BLANKER.....	52
ANTENNA REPORTS.....	53-55
BETA-COM INFO (UPGRADING 23 CHANNEL RADIOS).....	57-87

VOLUME 3

	PAGE #
PRESIDENT MADISON FREQ. COUNTER MOD.....	16-18
NOISE WHINE CURE.....	24
MICROPHONE WIRING INSTRUCTIONS.....	26-32
PLL CHANNELIZER.....	33-40
ANTENNA SECRETS (K40 STUD MOUNT FOR BIG STICK).....	63-64
SPECIAL SECTION ON LINEAR AMPLIFIERS:	
50-70W MOBILE.....	66
300-400W BASE.....	67-69
70W BASE.....	70-71
EAGLE 200.....	72
EAGLE 500.....	73
CONVERSION FROM AMATEUR TRANSMITTER TO LINEAR AMP...	74
LINEAR AMP PROBLEMS & SOLUTIONS.....	75-76

VOLUME 4

	PAGE #
HOW TO BUILD YOUR OWN RELAY MODULE.....	16
02A CHIP INFORMATION.....	54-55
HINTS & KINKS ON COBRA 62XLR & 142GTL.....	61
TURNER MIC EXPANDER (500MC DISABLE).....	62
K40 BLINKIE.....	63
SUNSPOT PREDICTION CHART.....	64
LINEAR REPORT SECTION:	
D & A MAVERICK.....	65
D & A 500 TRIPLE CONVERSION.....	65
EAGLE 515 MODIFICATION.....	66-67
UNIDEN SSB 10METER POWER CONVERSION.....	68-70
SUPER CLARIFIER DIODE.....	71

VOLUME 5

	PAGE #
10 METER CONV. MICROCOMPUTER (MICROMONITOR PLL).....	1-5
ECHO BOX.....	6
250 WATT DUMMY LOAD - "SECRET CB'S LITTLE DUMMY".....	7
BUILT IN POWER MIKE.....	8-9
5-MILE SIMULATOR.....	10
RECEIVER PRE-AMP.....	11
GLEN DIGITAL CONTROLLER.....	12-13
GETTING SWR DOWN ON BASE ANTENNAS.....	15
APARTMENT ANTENNA.....	16
GROUNDING MOBILE RADIOS.....	17
OOPS! WE GOOFED!	
VOL. 1, PAGE 23.....	18
VOL. 2, PAGE 20 & 21.....	18
VOL. 3, PAGE 4, 7, 11, 25, 33.....	18
VOL. 4, PAGE 5, 45, 50.....	17

VOLUME 5 (cont.)

	PAGE #
DAK MARK IX POWER MODIFICATION.....	21-23
SUPER POWER MODULATION MOD. FOR BOWMAN BASE CBH990..	43
THE ART OF WIDEBANDING 858 CHIP.....	44
CONVERSION KIT + MARS & CAP FOR SSB.....	48-49
CONVERSION OF AM/SSB TO 10 METER AMATEUR.....	52
REDCO UFO INSTALLATIONS.....	61-69
HINTS & KINKS - COBRA 140/142/148GTL REGULATOR IC SHORTING OUT.....	70
SLIDE INCREASE, ALL SSB RADIOS.....	71
RADAR COMMUNICATOR.....	72-73

VOLUME 6

	PAGE #
PLL CRYSTAL CROSS REFERENCE GUIDE.....	1-2
SECRET CB TEST TONE.....	13
ERRONEOUS SIGNAL LOCATOR.....	14
LOW COST AMATEUR CONVERSION FOR 10 METERS.....	15
BASE ANTENNA GROUNDING.....	16-17
SUPER CLARIFIER 10-TURN POT.....	22
OOPS! WE GOOFED!	
VOL. 5, PAGE 19, 20, 28.....	25
THUMBWHEEL 200 CHANNEL CONVERSION FOR 858 CHASSIS..	31-34
REDCO UFO APPLICATIONS.....	40-52
SPECIAL SECTION ON LINEAR AMPLIFIERS:	
PDX 400.....	54
D & A MAVERICK 250.....	55
MACO DUSTER 300, 750 & 1000 TRANSMITTER.....	56-57
MACO 75.....	58
500 CX & 700 CX 10 to 11 METER CONVERSIONS.....	58
RDX-75.....	59
HDX-50.....	59
MDX-200.....	60
PDX-400.....	61
10 METER EXPERIMENTER BOARD INFORMATION.....	62-63
HOW TO MAKE CYBERNET CHASSIS SLIDE.....	65
HOW TO HOOK UP GLEN 310 TO PRESIDENT WASHINGTON....	67
SUPER CLARIFIER HINTS.....	66
REDCO DX-50.....	68-70

VOLUME 7

	PAGE #
HOW TO MAKE YOUR EAGLE SCREAM.....	14
IMPROVED SLIDE MODIFICATION FOR 02A SSB RADIOS.....	42
UPDATED 200 CHANNEL AMATEUR CONVERSION FOR 858 CHIP	43-48
10 METER CONVERSION FOR SSB RADIOS USING MB8719....	49-50
HOW TO MAKE YOUR 858 CHASSIS SLIDE.....	56
LINEAR AMPLIFIER NOTES.....	57
RECEIVE AMP - SILTRONIX.....	58-59
ECHO BOX SPEECH PROCESSING FOR TRC-449.....	60
ADDING PING.....	61
CORRECTION TO THUMBWHEEL 200 CHANNEL CONVERSION....	62-63
MICROMONITOR TECH NOTES.....	64-69
MICROMONITOR INSTALLATION for RADIOS USING 858....	70-71
AMP FOR RF PROBE.....	72
OSCILLOSCOPE MOD. FOR RF & MODULATION DISPLAY....	73
THE "BANDIT" ANTENNA.....	74-76
SECRET CB'S OWN "TROUBLESHOOTER".....	77

VOLUME 8

	PAGE #
WHAT'S NEW ON THE ELECTRONICS HORIZON?.....	1-6
UHF FM CB (GMRS).....	7-10
UNIDEN MB8719 PLL CHIP FREQUENCY CONVERSION.....	15
FREQUENCY MOD. FOR J.C. PENNEY, COLT, LAFAYETTE, HYGAIN, ETC.....	18
BROWNING MARK IVA MOD. & UFO INSTALLATION.....	22-23
BROWNING MARK IV TRANSMITTER TROUBLESHOOTING.....	25-32
OOPS! WE GOOFED!	
VOL. 5, PAGES 31, 32, 33, 34.....	41
VOL. 7, PAGES 31, 37.....	42-43

VOLUME 3 (cont.)

PAGE #

LINEAR AMPLIFIER NOTES:
 INSTALLING & TROUBLESHOOTING LINEAR AMPS..... 47-49
 10 METER AMP BOARD MOD. TO UPRIGHT DRIVER..... 50
 YOU CAN BUILD IT:
 TWO-TONE GENERATOR..... 51
 YAESU 601 (B) FREQ. COUNTER MOD. TO READ
 CB LOW, MIDDLE, HIGH FREQ..... 52-54
 RF TEST METER..... 56-57
 REDCO UFO MODIFICATION (FROM 20 to 29.995 MHz).... 55
 SECRET CB'S POWER VECTORING..... 58
 HOW THE ECHO BOX CAN ACTUALLY SURPASS THE POWER
 OF A LINEAR IN SSB..... 59
 MICROMONITOR QUESTIONS..... 60-62
 MICROMONITOR INSTALLATION INSTRUCTIONS:
 SM5104 PLL..... 63-64
 ICOM 22S..... 65-67
 NEW PRODUCT RELEASE:
 ZAPPER 9000 MOD. & REFERENCE CHART..... 68-69
 REDCO DIGI-SCAN UFO ELITE..... 70
 CHOPPER CHARLIE ANTENNA, MODEL 6445..... 71
 TROUBLESHOOTER..... 73
 AMATEUR VSB-1 (VOICE SIGNAL BOOSTER)..... 82

VOLUME 9

PAGE #

SSB'ER LOSE OUT AGAIN..... 1
 FCC ANNOUNCES PLANS FOR SIDEBAND..... 2-3
 FCC DELAYS NPRM: SSB FREQS. DOUBTFUL..... *3-4
 SPEED-O-MATIC "SPEEDO-1" X-BAND RADAR GUN..... 5-6
 CONVERSION TIPS FOR ALL SSB RADIOS..... 7
 RELAY CRYSTAL SWITCHING..... 25-26
 LETTER FROM A FRIEND..... 27-28
 HINTS & KINKS-ELECTRONIC CRYSTAL SWITCHING..... 29
 OOPS! WE GOOFED! VOL. 8, PAGE 17..... 29
 SOLVING T.V.I..... 40-42
 RADACRUZ..... 42
 IMPORTANT FACTS ABOUT ECHO BOXES..... 43-44
 OOPS! WE GOOFED! VOL. 4, PAGE 51..... 44
 VOICE SIGNAL BOOSTER (VSB-1) INSTALLATION..... 45-48
 POWER SUPPLY MODIFICATION FOR REALISTIC PRE-AMP
 NOISE-CANCELLING MIKE #21-1175..... 49-50
 HINTS & KINKS - SWITCHABLE MODULATION INCREASE..... 51
 RF ATTENUATOR..... 52-54
 PRESIDENT SERVICE BULLETINS..... 55-61
 INDEX VOLUMES 1 THRU 8..... 62-70

VOLUME 10

PAGE #

SECRET CB TROUBLESHOOTER..... 2-4
 VOICE SIGNAL BOOSTER - VSB-1..... 5-19
 REPLACING MB8734 with MB8719..... 35
 UPD2816C PLL PIN OUT..... 42
 TECH TIPS ON 858..... 55
 UNCONVERTIBLE CHIP LIST..... 66
 LINEAR SUGGESTIONS..... 68-69
 ZAPPER 9000 INSTALLATION HINTS..... 70
 OOPS! WE GOOFED!
 VOL. 3, PAGE 33..... 71
 VOL. 5, PAGE 24, 28, 48..... 72
 VOL. 8, PAGE 16, 17..... 72-73
 VOL. 9, PAGE 9, 51..... 74-75
 VOL. 9, PAGE 29..... 72
 CB PARABOLIC TYPE ANTENNA..... 77

VOLUME 11

PAGE #

CPI ALC MODIFICATION FOR INCREASED SSB POWER..... 9
 HOW TO ADD RF GAIN CONTROL TO A CPI 300/400..... 11
 VSB-1 UPDATE..... 25-26
 NEW FRONTIER: FM CB..... 27-29
 NEW PRODUCT: DIGI-SCAN DS-400..... 30-31

VOLUME 11 (cont.)

PAGE #

COMING ATTRACTIONS - SERIAL DATA/PLL
 FREQUENCY SYNTHESIZERS..... 32
 UNCONVERTIBLE AT THIS TIME -GE 3-5900A TC9101P.... 33
 ADD CH. 9 & 19AT TO COLT 210..... 33
 ZAPPER 9000 INSTALLATION UPDATES..... 34
 RADIO MODULATION ADJUSTMENTS FOR VARIOUS MODELS... 51-53
 HINTS ON SERVICING..... 54
 SERVICE NOTES-GOLDEN EAGLE MARK IV TRANSMITTER... 55
 D104 & D104M6 ASTATIC MIKE MODIFICATION..... 55
 HOW TO SOLVE NOISE PROBLEMS..... 56-57
 MORE ON THE "TROUBLESHOOTER"..... 57
 NOISE IN DIESEL TRUCKS..... 58
 IN HOUSE VALUE LISTING..... 59
 TRUCKERS SPECIAL POLARITY PROTECTOR WITH SMARTS... 60
 HOW TO BUILD:
 LOW PASS FILTER..... 61
 20dB ATTENUATION PAD..... 61
 BALUN COIL..... 62
 1000Hz TONE..... 63
 ADD A SECOND BATTERY..... 64
 20 AMP POWER SUPPLY..... 65
 SIGNAL INJECTOR..... 66
 CMOS LOGIC PROBE..... 67
 REFERENCE OSC-DIVIDER..... 68
 READOUT MODIFICATION..... 69
 ASTATIC MIC MOD..... 70
 BILATERAL SWITCH..... 71
 PLL PINOUT DIAGRAMS..... 72-77
 THE "BANDIT" ANTENNA..... 53
 OOPS! WE GOOFED!
 VOL. 3, PAGE 25..... 78
 VOL. 6, PAGE 32..... 78
 VOL. 7, PAGE 43, 53, 63..... 78
 VOL. 8, PAGE 52..... 78
 VOL. 10, PAGE 2..... 78

VOLUME 12

PAGE #

SIMPLE CURE FOR RX-TX TRACKING PROBLEMS..... 21
 HAM RADIO CRYSTAL SELECTOR GUIDE..... 24
 VSB-1 HOOK-UP:
 TEABERRY STALKER XX..... 25
 REALISTIC TRC-490..... 25
 WARDS GEN-719A..... 25
 MODULATION ADJUSTMENTS FOR VARIOUS REALISTICS..... 33
 ZAPPER 9000 REFERENCE CHART..... 46
 ZAPPER TROUBLESHOOTING HINTS..... 47-48
 TC9106 PLL OPERATION ANALYSIS..... 50-53
 THE "SPREAD EAGLE" ANTENNA BREAK-THRU FOR TRUCKERS. 54-55
 BASIC PLL..... 56
 ELECTRONIC TERMINOLOGY..... 57
 SCANNER PROGRAMMING TIPS..... 58
 INTO THE KNOW WITH JAPANESE SEMICONDUCTORS..... 59
 TRANSISTOR SPECIFICATIONS..... 60
 RESISTOR COLOR GUIDE..... 61-62
 CAPACITOR CODES..... 62
 YOU CAN BUILD IT:
 "SECRET CB'S" SUPER-DUPER POWER
 SUPPLY CONTROLLER..... 63
 AUDIO TEST STATION..... 64
 POWER LINE FILTER - T.V.I. FILTER..... 65
 OOPS! WE GOOFED!
 VOL. 4, PAGE 38..... 66
 VOL. 10, PAGE 10, 16, 28..... 66
 VOL. 11, PAGE 3, 10, 15, 16, 71..... 66
 INDEX VOLUMES 1 THRU 11..... 67-78

VOLUME 13

	PAGE #
INTRODUCING THE SOMMERKAMP TS-788DX.....	4-9
MB8719 PINOUT.....	32
AGC SELECTOR SWITCH.....	38
CYBERNET 02A CHASSIS.....	39
HOW TO HOOK UP A 10 TURN PCT TO 2000 GTL.....	40
2824C OPERATION ANALYSIS.....	41-43
VSΒ-1 HOOK-UP: TRC-448 & MIDLAND 77-0004 4001.....	43-44
TROUBLESHOOTING CLARIFIER PROBLEMS ON THE 858.....	45-47
SUPER REGULATOR.....	48
BUILD A RECEIVER PREMP.....	49
LINEAR NOTES.....	50-51
MODULATED GUNN OSCILLATOR.....	52-56
CYBERNET 02A AM POWER INCREASE.....	59
REALISTIC DX300 (20-204).....	64
BEARCAT 250.....	65
OOPS! WE GOOFED!	
VOL. 4, PAGE 39.....	66
VOL. 6, PAGE 3 & 12.....	66
VOL. 7, PAGE 54.....	66
VOL. 10, PAGE 25 & 48.....	66-67
VOL. 11, PAGE 4, 6, 10, 41, 75.....	67
INDEX VOLUMES 1 THRU 12.....	68-80

VOLUME 14

	PAGE #
MB8719/11.3258 TRUTH TABLE.....	15-17
NEW PRODUCT: FM-30B THRU-LINE FREQ. COUNTER.....	18-19
NEW! "KIT A" FOR LC7130/7131 & TC9106P	
CHIPS & INSTALLATION ISNTRUCTIONS.....	20-40
BROWNING PING INFORMATION.....	41
25-29 MHz FREQUENCY ASSIGNMENTS.....	62-63
ELECTRONIC TERMINOLOGY.....	63
YOU CAN BUILD IT!	
PET RECEIVER PRE-AMP.....	64
BUILD YOUR OWN SPACE SOUND.....	65
BUILD AN AMPLIFIER.....	66-67
INDEX FOR VOLUMES 1 THRU 13.....	68-80

VOLUME 15

	PAGE #
NEW MICROSCAN PLUS SYSTEM.....	5-6
BREAKING THAT CHIP.....	7-11
02A TRUTH TABLE.....	12-13
MEASURE FREQUENCY ON SCOPE.....	17
PM77 POWER MODULATOR KIT.....	19
DIGITAL PROCESSOR KIT/UPD2824.....	28
WIRE GAUGE CONVERSION CHART.....	41
02A 23 CHANNEL AM MOD.....	59
POWER MOD. FOR AM UNITS.....	65
PRE-CONVERSION TIPS.....	70
CONVERT A SALVAGED METER TO VOLT METER.....	71
STATE/INTERNATIONAL DISIGNATORS.....	72
OOPS! WE GOOFED!	
VOL. 12, PAGE 7.....	69
VOL. 13, PAGE 63.....	69
VOL. 14, PAGE 12.....	69
INDEX FOR VOLUMES 1 THRU 14.....	73-79

VOLUME 16

VSΒ-1 (COBRA 2000) UPDATE.....	6
SAMS CB MANUAL - OUT OF PRINT.....	7
CALL SIGNS/FREQUENCY CHARTS.....	9-20
HINTS/KINKS/GOOFS.....	31
M58472P PLL CHIP MOD.....	33
OSCILLATOR CHECKER, LOW CAPACITY PROBE.....	34
TROUBLESHOOTER GUIDE.....	35-36
INTO THE KNOW WITH POTS.....	37
"MY WAY" SLIDE.....	38
BLEED-OVER FILTER.....	40
LOOP FILTER - WHAT IS IT?.....	42
COLOR CODE GUIDE FOR CHOKES.....	42
ANTENNA INFORMATION.....	56
02A CLARIFIER/BANDSWITCH MOD.....	57-59
HIGH CURRENT METER.....	63-64
SWR VS REFLECTED POWER CHART.....	65
CUSTOM FREQUENCY STANDARD.....	66-67
CHECKING MODULATION.....	69
DIGITAL PROCESSOR KIT (#146) UPDATE.....	70-71
OOPS! WE GOOFED!	
VOL. 1, PAGE 61.....	72
VOL. 12, PAGE 28.....	72
VOL. 13, PAGE 27.....	72
VOL. 14, PAGE 22, 41.....	72
VOL. 15, PAGE 63, 65.....	72
INDEX FOR VOLUMES 1 THRU 15.....	73-80

VOLUME 17

	PAGE #
'B' KIT.....	4-33
SECRET CB KIT #106 for TRC-451.....	36-38
M58472P PLL CHIP (UPDATE).....	39
FORGOTTEN ACCIDENT (23 ch. xtal conv. info).....	39
148GTL-B SCHEMATIC.....	43
PALOMAR 2400 SCHEMATIC.....	44
COLT 510 SCHEMATIC.....	45
COMMTRON XII SCHEMATIC.....	45
HINTS/KINKS/GOOFS.....	46
U-BUILD IT - BURGLAR ALARM.....	48
U-BUILD IT - CUSTOM REGULATED POWER SUPPLY.....	49-50
GYPSY FREQUENCY CHART/KIT INFO.....	51-52
PLL CHIP INFO.....	59
REALISTIC PRO-54 SCANNER (D.C. MOD.).....	62-64
VIDEO "DUBBING/COPYING" TIPS.....	64-65
VCR VIDEO MOD. TRS-80 VIDEO DISPLAY.....	66-69
OOPS! WE GOOFED!..CORRECTIONS:	
VOL. 4, PAGE 54 - 02A CHIP INFO.....	70
VOL. 15, PAGE 58 - TRISTAR 747.....	70
VOL. 16, PAGE 50 - 148GTL-DX (EARLY).....	70
VOL. 16, PAGE 72 - RAY JEFFERSON.....	70
INDEX VOLUMES 1 thru 16.....	71-78
OOPS! WE GOOFED! INDEX.....	78
CROSSWOOD PUZZLE.....	79

VOLUME 18

	PAGE #
SUPER STAR 360 SCHEMATIC.....	4
EXPORT ROUNDUP INFO.....	5-12
MB CHASSIS SERVICE NOTE.....	13
CAUTION-CIRCUITS-QUICKIE.....	14
SM5104 PLL FREQUENCY MOD. (AM CHASSIS).....	20-21
10KHz FLIP-FLOP.....	23
REALISTIC PRO-22 (SPECIAL NOTES).....	33
PARTS INFO: LAFAYETTE, COLT, SBE, PALOMAR.....	34
TROUBLE SHOOTING TABLES - SSB UNITS:	
REC86345, 02A (2-BOARD), 858, 8734/8719, 2824/2816.....	35-39
LINEAR TIPS FOR SQUEAL ON TX.....	41
HINTS/KINKS/GOOFS.....	42
ROBYN OWNERS-PARTS SOURCE & TECH NOTES.....	43
HELP WANTED.....	43
861PLL AM CHASSIS (UPDATE).....	45
CONVERSION CHARTS.....	46
MB8719 WITH 11.1125 CRYSTAL INFO.....	47
RADIO SHACK MIKE WIRING.....	48-49
\$MONEY MAKERS\$.....	50
ANTENNA TUNING.....	51
KIT 137 INSTALLATION INSTRUCTIONS & SPEC.....	52-53
LARK FREQUENCY CHART.....	54
SAMS CB/SCANNER MANUAL '84 UPDATE.....	55
\$\$INDIVIDUAL I.R.A. - TUBES\$\$.....	57
SURVEY RESULTS.....	58-59
SAVE THE CHIP-MAYBE THE METER.....	60
REMOTE CONTROL OF AMPLIFIER.....	61
THINK SMALL! CRYSTAL INFO.....	62
VIDEO (UPDATE).....	63-65
ANTENNA MOUNTING-MOBILE.....	66
VOLTAGE REGULATOR DESIGN.....	69
ALL ABOUT CRYSTALS.....	70
CORRECTIONS:	
VOL 5, PAGE 47 - MIDLAND 79-900.....	62
SECRET CB Kit 27A.....	79
VOL 9, PAGE 12 - CRAIG L-131/L-231.....	79
VOL 7, PAGE 28 - ROBYN SB-540-D.....	79
VOL 10, PAGE 49 - CRAIG L232/L132	79
INDEX VOLUMES 1 thru 17.....	71-78
WORKSHEET FORM.....	80

VOLUME 19

	PAGE #
EARS.....	5-7
EXPORT ROUNDUP.....	10-17
ED. NOTES.....	18
CAUTION-DOUBLE BOARD EXPORTS.....	31
DOUBLING-UP FOR CURRENT.....	31
CROSS-REFERENCE ON SAMS CB MANUALS.....	32-33
SERVICE TIPS - EXPORT - CYBERNET 02A PLL.....	37
GEORGE FREQUENCY CHART.....	38-39
ALPHA FREQUENCY CODE CHART.....	43
POLARITY PROTECTOR AND OVER-VOLTAGE PROTECTION....	44
DUOFONE ET-350 (R/S 43-366).....	45
HOW TO ORDER CRYSTALS.....	47
"SECRET CB" SUPER CLARIFIER DIODE & SUPER SLIDE... ..	53
BONUS - HAVING TROUBLE BROADBANDING ON UNITS?.....	54
ROYCE OWNERS PARTS INFO.....	54
CORRECTION FOR 10KC FLIP-FLOP, VOL. 18, Pg. 23.....	54
HINTS/KINKS/GOOFS.....	55
FREQUENCY CHART FOR 10KHz FLIP FLOP MOD IN VOL 18.	56
MODULATION SWITCH - 858 SSB CHASSIS.....	59
WARNING-ANTENNA'S.....	59
TROUBLE SHOOTING TIP - 858 SSB CHASSIS.....	60
BLEED OVER FILTER (UPDATE).....	61
SALVAGE OF POWER SUPPLIES.....	62
VIDEO TAPE.....	63
858 SSB CHASSIS - ADJACENT CHANNEL REJECTION.....	67
INDEX VOLUMES 1 THRU 18.....	70-78
CORRECTION INDEX.....	79

CORRECTIONS

Vol. 10, pg. 67; RE: TRC-441, see page 42 this volume.

Vol. 19, pg. 20; RE: Stalker 9FDX Schematic.
CHANGE HEADING FROM LATE VERSION TO U.K. VERSION.

Vol. 19, pg. 35; RE: Grant Slide.
DELETE - Step 5 completely...