

MS1404

RF & MICROWAVE TRANSISTORS UHF MOBILE APPLICATIONS

Features

- 470 MHz
- 12.5 VOLTS
- P_{OUT} = 5.0 WATT
- G_P = 8.5 dB MINIMUM
- COMMON EMITTER CONFIGURATION

DESCRIPTION:

The MS1404 is a 12.5V Class C epitaxial silicon NPN planar transistor designed primarily for UHF communications. This device utilizes improved metallization to achieve infinite VSWR at rated operating conditions.

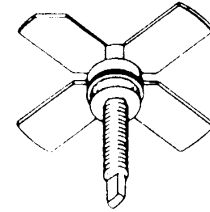

.280 4L STUD (M122)
epoxy sealed

PIN CONNECTION

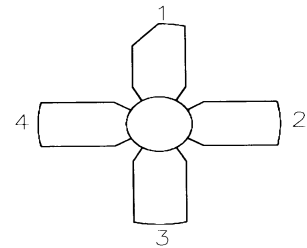

1. Collector 3. Base
2. Emitter 4. Emitter

ABSOLUTE MAXIMUM RATINGS (T_{case} = 25°C)

Symbol	Parameter	Value	Unit
V _{CBO}	Collector - Base Voltage	36	V
V _{CER}	Collector - Emitter Voltage	18	V
V _{CES}	Collector - Emitter Voltage	36	V
V _{EBO}	Emitter- Base Voltage	4.0	V
P _{DISS}	Power Dissipation	37	W
I _C	Device Current*	2.0	A
T _J	Junction Temperature	+200	°C
T _{STG}	Storage Temperature	-65 to +150	°C

Thermal Data

R _{TH(J-C)}	Thermal Resistance Junction-case	11.6	°C/W
----------------------	----------------------------------	------	------

ELECTRICAL SPECIFICATIONS (T_{case} = 25°C)
STATIC

Symbol	Test Conditions		Value			Unit
			Min.	Typ.	Max.	
BV _{CES}	I _C = 10 mA	V _{BE} = 0 mA	36	---	---	V
BV _{CEO}	I _C = 50 mA	I _B = 0 mA	16	---	---	V
BV _{EBO}	I _E = 2 mA	I _C = 0 mA	4.0	---	---	V
I _{CBO}	V _{CB} = 15 V	I _E = 0 mA	---	---	1	mA
HFE	V _{CE} = 5 V	I _C = 200 mA	20	---	---	---

DYNAMIC

Symbol	Test Conditions			Value			Unit
				Min.	Typ.	Max.	
P _{OUT}	f = 470 MHz	P _{IN} = 0.70 W	V _{CC} = 12.5V	5.0	---	---	W
G _p	f = 470 MHz	P _{IN} = 0.70 W	V _{CC} = 12.5V	8.5	---	---	dB
C _{OB}	f = 1 MHz	V _{CB} = 12 V		---	19	---	pF

IMPEDANCE DATA:

FREQUENCY	Z _{in} (Ω)	Z _{cl} (Ω)
450 MHz	1.4 + j 2.0	10.4 - j 6.9
470 MHz	1.4 + j 2.9	11.4 + j 5.8
512 MHz	1.5 + j 3.4	11.9 + j 3.2

PACKAGE MECHANICAL DATA

PACKAGE STYLE M122

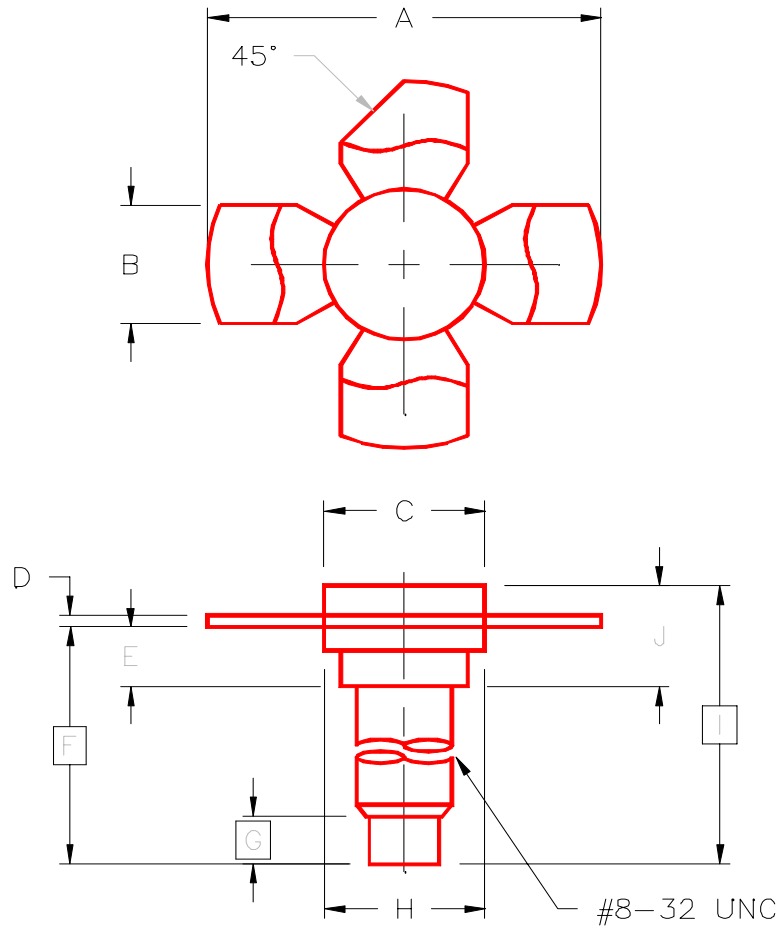

	MINIMUM INCHES/MM	MAXIMUM INCHES/MM		MINIMUM INCHES/MM	MAXIMUM INCHES/MM
A	1.010/25,65	1.055/26,80	I	.640/16,26	
B	.220/5,59	.230/5,84	J	.175/4,45	.217/5,51
C	.270/6,86	.285/7,24			
D	.003/0,08	.007/0,18			
E	.117/2,97	.137/3,48			
F	.572/14,53				
G	.130/3,30				
H	.275/6,99	.285/7,24			